

OBJECT: 5KCP39HGAA11BT DATE: 08-NOV-11 19:45:19

VENTILATION SYSTEM		RBC PROPRIETARY AND CONFIDENTIAL INFORMATION This document is the property of REGAL BELOIT CORPORATION ("RBC") including its subsidiaries and divisions and contains proprietary information of RBC. This document is loaned on the express condition that neither it nor the information contained therein shall be disclosed to others without the express written consent of RBC, and that the information shall be used by the recipient only as approved expressly by RBC. This document shall be returned to RBC upon its request. This document may be subject to certain restrictions under U.S. export control laws and regulations.	REVISIONS			
SHELL VENTS	OPEN		REV.	DESCRIPTION	DATE	APPROVED
ENDSHIELD (OPP. LEAD END)	OPEN		1	REL TO PROD PER IS:11-2171	11/08/11	PRANEETH
ENDSHIELD (LEAD END)	OPEN					

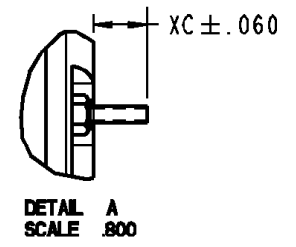
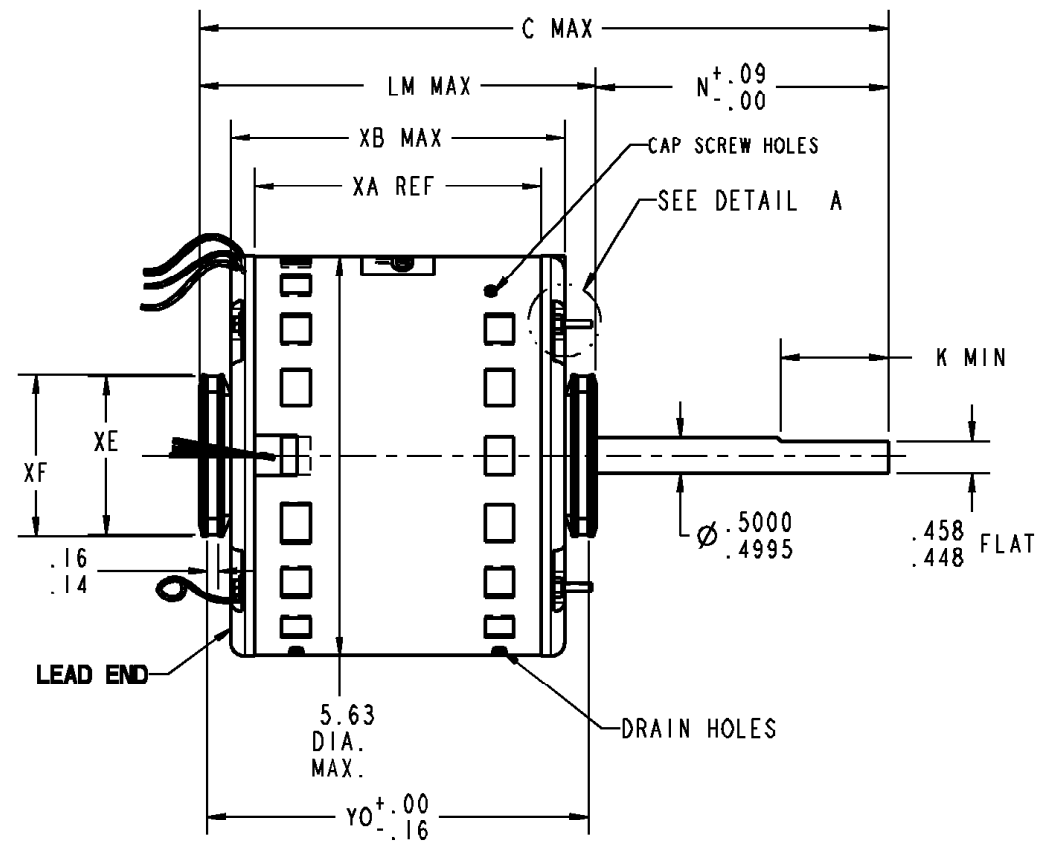
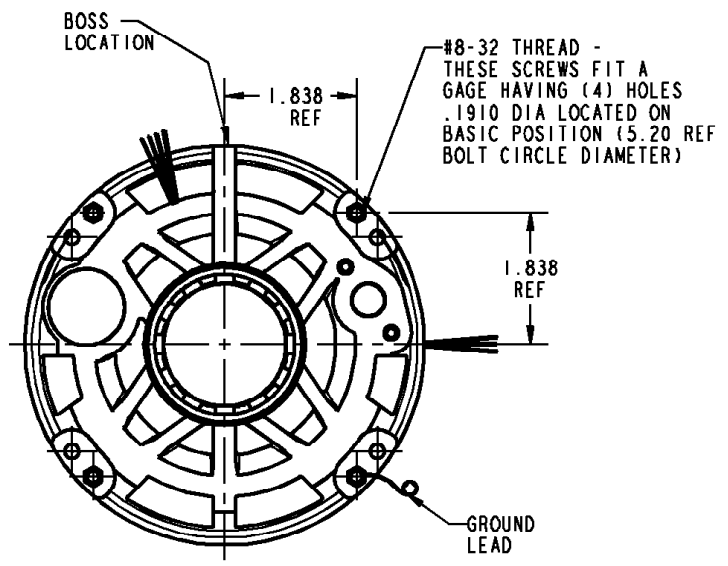

NOTE:
1. DIMENSIONS SHOWN ARE NOMINAL UNLESS OTHERWISE SPECIFIED.

			2.22	2.25	.59	N/A	5.14
			XE	XF	XC	XD	YO
9.39	4.00	3.62	N/A	N/A	5.34	3.82	4.48
C	N	K	XN	XK	LM	XA	XB

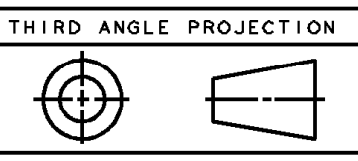

NO	CONNECTION	COLOR	ENT TYPE	ENT LOC (MEAS LB)	GAGE	MATERIAL	WALL THK	LENGTH	TERMINATION
1	COMMON LEAD	YELLOW	SHELL NOTCH	3:00	18	THERMOPLASTIC	4/64	26.00	.50 BWS
2	REV LEAD	YELLOW	E/S VENT	11:20	18	THERMOPLASTIC	4/64	4.00	.25 STRT QC/INS/ML
3	CAPACITOR LEAD	BRN/WHT	SHELL NOTCH	3:00	18	THERMOPLASTIC	4/64	26.00	.25 STRT QC
4	REV LEAD	ORANGE	E/S VENT	11:20	18	THERMOPLASTIC	4/64	4.00	.25 STRT QC/INS/ML
5	CAPACITOR LEAD	BROWN	SHELL NOTCH	3:00	18	THERMOPLASTIC	4/64	26.00	.25 STRT QC
6	REV LEAD	BROWN	E/S VENT	11:20	18	THERMOPLASTIC	4/64	4.00	.25 STRT QC/INS
7	HIGH SPEED LEAD	BLACK	SHELL NOTCH	3:00	18	THERMOPLASTIC	4/64	26.00	.50 BWS
8	LOW SPEED LEAD	RED	SHELL NOTCH	3:00	18	THERMOPLASTIC	4/64	26.00	.50 BWS
9	REV LEAD	PURPLE	E/S VENT	11:20	18	THERMOPLASTIC	4/64	4.00	.25 STRT QC/INS
10	GROUND	GRN-YEL	CLAMPSCREW	4:30	18	THERMOPLASTIC	2/64	12.00	#10 EYELET

NAMEPLATE DATA	
MODEL	5KCP39HGAA11BT
CUST P/N	STOCK NO 3386
HP	1/3
RPM	1075
VOLTS	208-230
HZ	60/50
SPEEDS	2
AMPS	2.90
CAP REQD-1	5.00µfd/370Volts
CAP REQD-2	N/R
CONN. DRW	NP24X327715
ROTATION	CCW/CW (VIEWED FROM LE)

REGAL BELOIT REGAL-BELOIT CORPORATION FORTWAYNE, INDIANA

TITLE: **MOTOR OUTLINE**
(CUSTOMER NAME: DEF PUR)

SIZE B DRAWING **5KCP39HGAA11BT** REV 1

SCALE: NO ISSUED: 11/08/11 SHEET 1 of 1