

RBC PROPRIETARY AND CONFIDENTIAL INFORMATION
 This document is the property of REGAL BELOIT CORPORATION ("RBC") including its subsidiaries and divisions and contains proprietary information of RBC. This document is loaned on the express condition that neither it nor the information contained therein shall be disclosed to others without the express written consent of RBC, and that the information shall be used by the recipient only as approved expressly by RBC. This document shall be returned to RBC upon its request. This document may be subject to certain restrictions under U.S. export control laws and regulations.

LEAD	CONNECTION	COLOR	EXIT TYPE	EXIT LOC	GAGE	MATERIAL	WALL THICKNESS	LENGTH	TERMINATION
1	COMMON	WHITE	SHELL NOTCH	3:00	18	THERMO	4/64	26.00	BWS
2	HIGH	BLACK	SHELL NOTCH	3:00	18	THERMO	4/64	26.00	BWS
3	MED	BLUE	SHELL NOTCH	3:00	18	THERMO	4/64	26.00	BWS
5	LOW	RED	SHELL NOTCH	3:00	18	THERMO	4/64	26.00	BWS
6	REV	BROWN	SHELL NOTCH	3:00	18	THERMO	4/64	6.00	.25 MISQC
7	REV	ORANGE	SHELL NOTCH	3:00	18	THERMO	4/64	6.00	.25 MISQC
8	REV	YELLOW	SHELL NOTCH	3:00	18	THERMO	4/64	6.00	.25 MISQC
9	REV	PURPLE	SHELL NOTCH	3:00	18	THERMO	4/64	6.00	.25 MISQC
10	CAP	BROWN	SHELL NOTCH	3:00	18	THERMO	4/64	26.00	.25 SQC
11	CAP	BRN/WHI	SHELL NOTCH	3:00	18	THERMO	4/64	26.00	.25 SQC

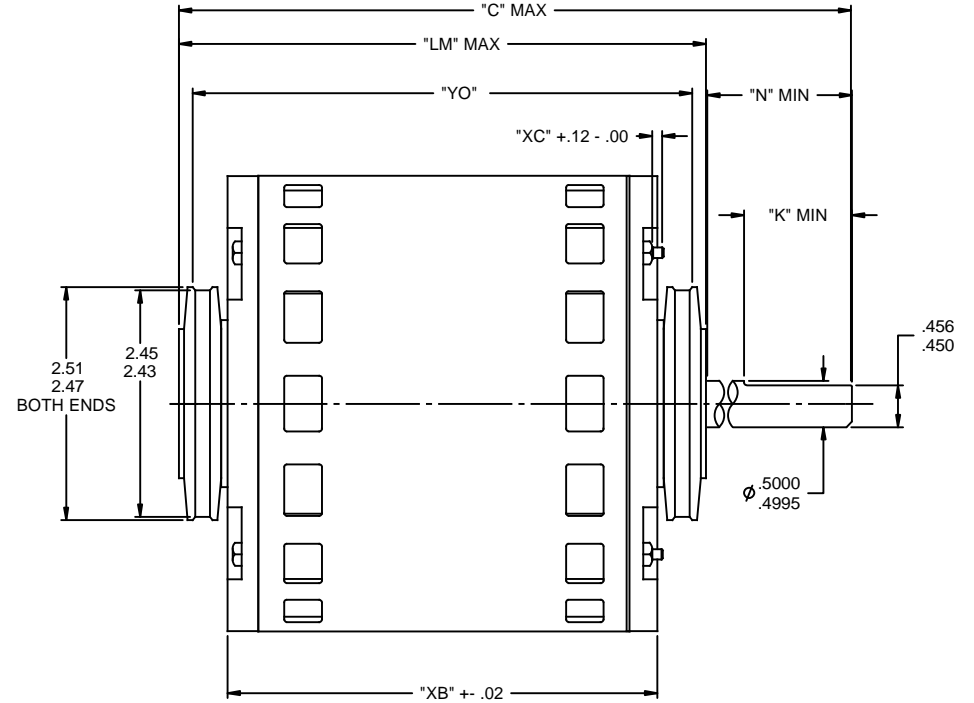
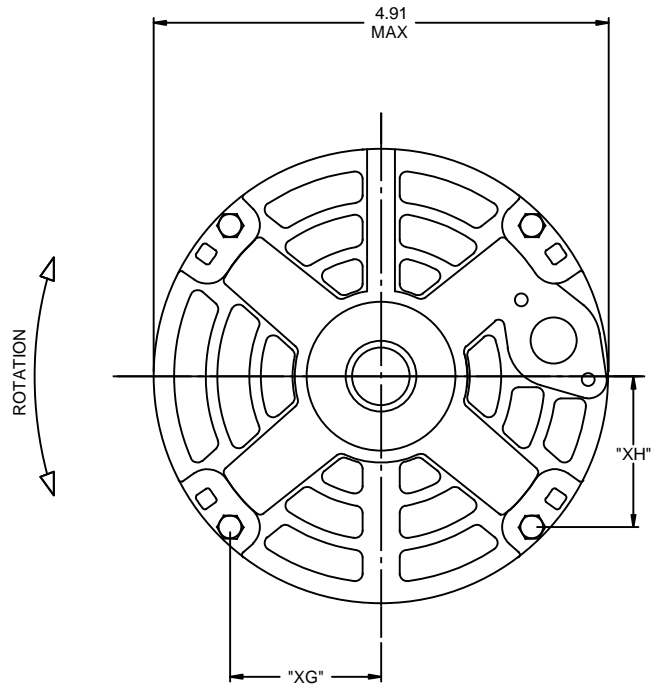

SPECIAL FEATURES
GROUND LEAD: 12.0" LG OUT OPE ES LEAD HOLE

ENCLOSURES	
END SHIELDS:	O.E.: OPEN P.E.: OPEN
SHELL:	O.E.: OPEN P.E.: OPEN

		TOLERANCES UNLESS SPECIFIED		REGAL BELOIT CORPORATION		DRAWN: GFS 12/07/10	
		DEC	INCHES	REGAL BELOIT CORPORATION		CHK	
		x	±.1	TITLE 29 FR OUTLINE		APPR	
03	OUTLINE REDRAWN IN SOLID WORKS	GFS 12/7/2010	GFS .xx	±.01			SCALE 1:1.33333
02	REVISED PROPRIETARY AND LOGO	GFS 7/28/05	GFS .xxx	±.005			REF
01	OUTLINE REDRAWN ON CAD	KMY 12/01/99	KMY .xxxx	±.0005	MATL		FMF STOCK
NO	REVISION	BY & DATE	CHK	ANG	±1/2"	FINISH	PAGE 1 OF 1
			RFP			PREV	SIZE DRAWING NO
							B 5KCP29KG5855S
							REV
							03