

NOTE: OUTLINE DIMENSIONS ON WHICH NO LIMIT IS SPECIFIED ARE NOMINAL AND NOT GUARANTEED AS TO TOLERANCE. ADDITIONAL INFORMATION ON TOLERANCES WILL BE FURNISHED ON SPECIFIC REQUEST.

NOTE: MOUNTING SCREW TORQUE 3.5 FT.LB.MAX.

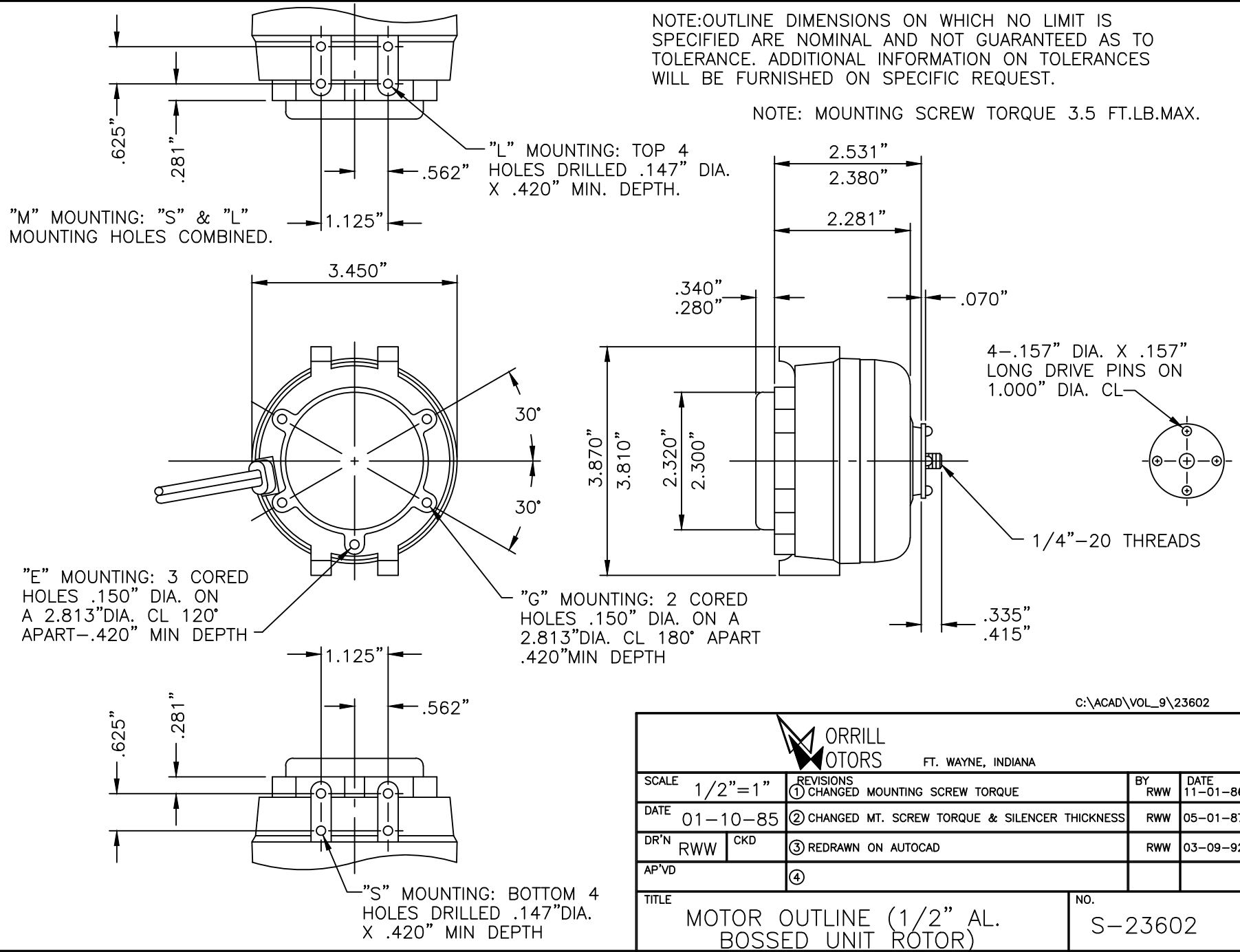

C:\ACAD\VOL\_9\23602

<b>ORRILL MOTORS</b> FT. WAYNE, INDIANA			
SCALE	1/2"=1"	REVISIONS	BY
DATE	01-10-85	① CHANGED MOUNTING SCREW TORQUE	RWW
DR'N	RWW	② CHANGED MT. SCREW TORQUE & SILENCER THICKNESS	RWW
AP'VD	CKD	③ REDRAWN ON AUTOCAD	RWW
		④	
TITLE			NO.
MOTOR OUTLINE (1/2" AL. BOSSED UNIT ROTOR)			S-23602