

S.NO	CONNECTION	COLOR	EXIT TYPE	EXIT LOC (VIEWING LE)	GAGE	MATERIAL	WALL THK.	LENGTH	TERMINATION
1	COMMON LEAD	WHITE	SHELL NOTCH	1:00	18	THERMOPLASTIC	4/64	27.00	.50 BWS
2	CAPACITOR LEAD	BRN/WHT	SHELL NOTCH	1:00	18	THERMOPLASTIC	4/64	27.00	.25 FQC
3	CAPACITOR LEAD	BROWN	SHELL NOTCH	1:00	18	THERMOPLASTIC	4/64	27.00	.25 FQC
4	HIGH SPEED LEAD	BLACK	SHELL NOTCH	1:00	18	THERMOPLASTIC	4/64	27.00	.50 BWS
5	LOW SPEED LEAD	RED	SHELL NOTCH	1:00	18	THERMOPLASTIC	4/64	27.00	.50 BWS
6	ISOLATED LEAD	ORANGE	SHELL NOTCH	1:00	18	THERMOPLASTIC	4/64	27.00	.50 BWS
7	REV LEAD	ORANGE	SHELL NOTCH	1:00	18	THERMOPLASTIC	2/64	5.50	.25 MALE ISQC
8	REV LEAD	YELLOW	SHELL NOTCH	1:00	18	THERMOPLASTIC	2/64	5.50	.25 MALE ISQC
9	REV LEAD	PURPLE	SHELL NOTCH	1:00	18	THERMOPLASTIC	2/64	5.50	.25 FISQC LO INS FORCE
10	REV LEAD	BROWN	SHELL NOTCH	1:00	18	THERMOPLASTIC	2/64	5.50	.25 FISQC LO INS FORCE
11	GROUND LEAD	GRN-YEL	CLAMPSCREW	1:30	18	THERMOPLASTIC	2/64	12.50	#10 EYELET

NAMEPLATE DATA	
MODEL	5KCP39PGWD71S
CUST. P/N	D915
HP	3/4-1/2
RPM	1075(2SPD)
VOLTS	460
HZ	60
SPEEDS	2
AMPS	2.30 1.70
CAP. REQ'D-D1	15.0 µfd/370 Volts
CAP. REQ'D-D2	N/R
CONN.DRW#	NP24X350359
ROTATION	CCW/CW (VIEWED FROM LE)

#8-32 THREAD. THESE SCREWS FIT A GAGE HAVING (4) HOLES OF Ø .1910 LOCATED ON BASIC POSITION. (5.20 REF BOLT CIRCLE DIAMETER)

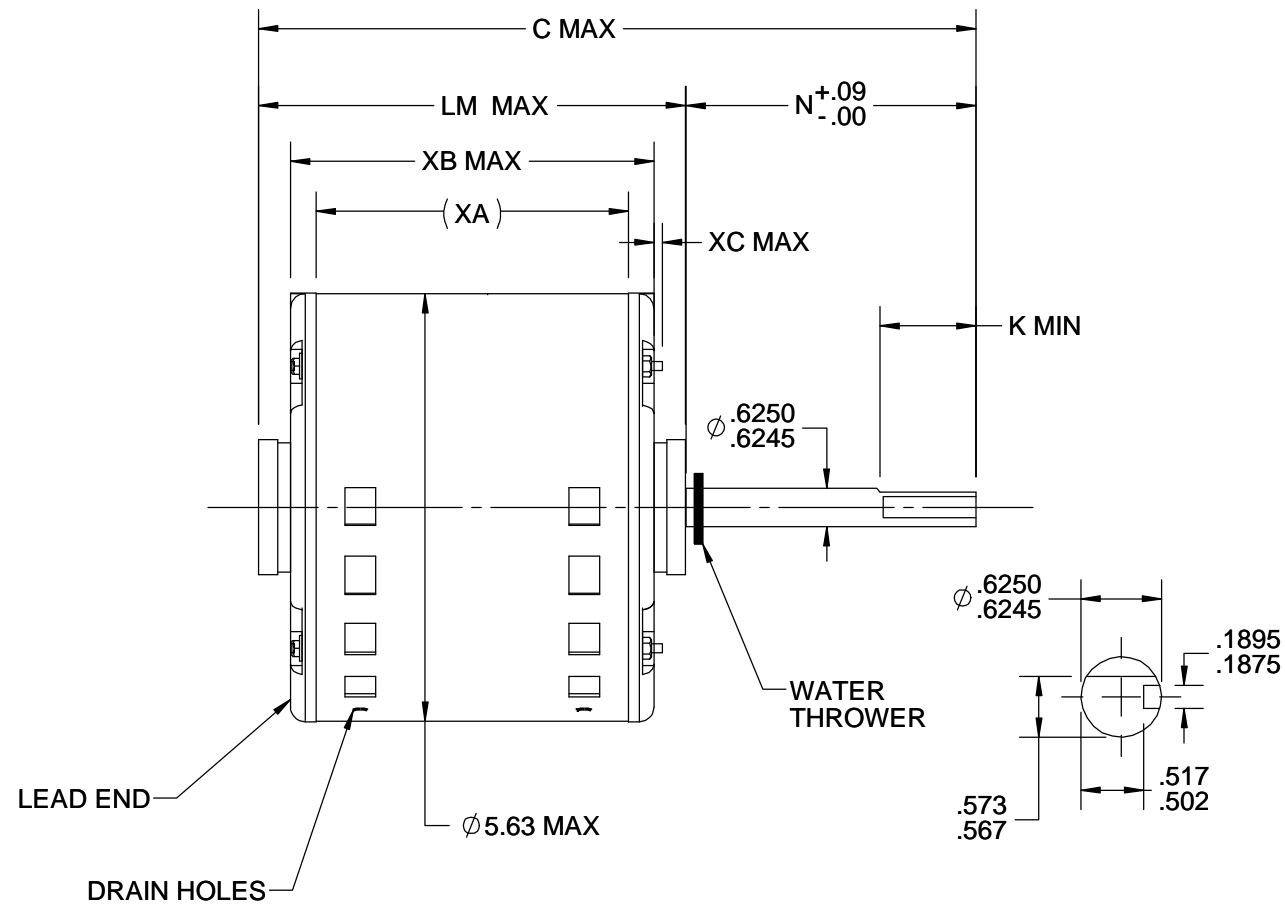
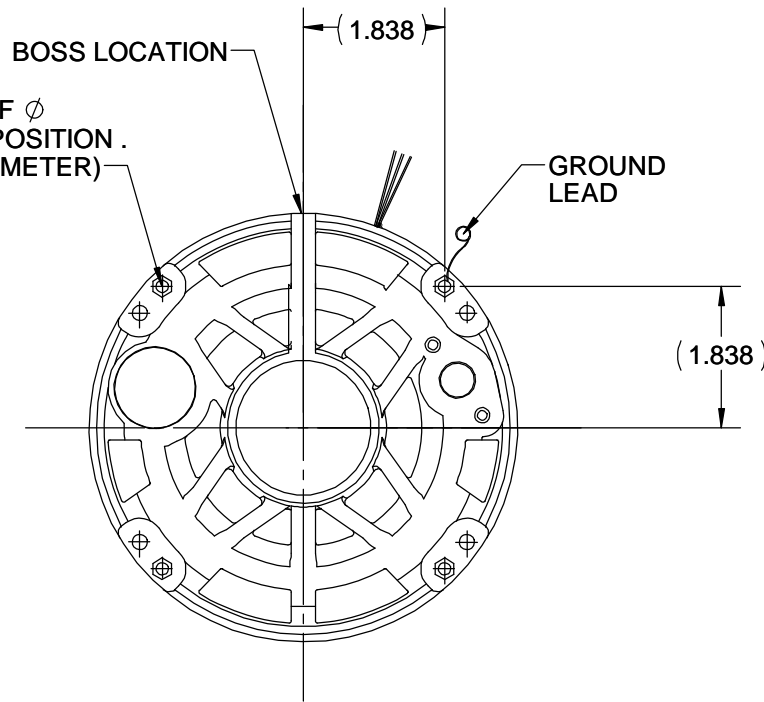

NOTE:

- 1) DIMENSIONS SHOWN ARE NOMINAL UNLESS OTHERWISE SPECIFIED.
- 2) NAME PLATE LABEL LOCATION : 315° - CENTER - READ FROM LE.
- 3) SHAFT KEY IS SECURED WITH MASKING TAPE TO THE SHELL.

1.50	N/R				
XC	XD				
10.39	4.00	3.04	6.31	4.82	5.48
C	N	K	LM	XA	XB

VENTILATION SYSTEM	
SHELL VENTS	OPEN(90° to 270 BOTTOM°)
ENDSHIELD (OPP.LEAD END)	CLOSED
ENDSHIELD (LEAD END)	OPEN

DRAWING REVISION F	REVISION BY RS	DATE 09/19/2017
ECO ECO-0131366	APPROVED BY LESTER MANZ	DATE 09/19/2017
ECO DESCRIPTION ADDED NOTE 3 FOR KEY AS PER ECO		
<small>COPYRIGHT REGAL BELOIT AMERICA, INC. ALL RIGHTS RESERVED. PROPRIETARY AND CONFIDENTIAL INFORMATION - THIS DOCUMENT IS THE PROPERTY OF REGAL BELOIT AMERICA, INC. ("OWNER") AND CONTAINS OWNER'S PROPRIETARY INFORMATION. ANY PERSON, CORPORATION OR OTHER FIRM RECEIVING IT IS DEEMED, BY RECEIVING IT, TO AGREE THAT IT, AND/OR ANY PART OF IT, SHALL NOT BE DISCLOSED TO ANY PERSON, CORPORATION OR OTHER ENTITY, DUPLICATED, AND/OR USED, EXCEPT AS EXPRESSLY APPROVED IN WRITING IN ADVANCE BY OWNER. THIS DOCUMENT SHALL BE RETURNED TO OWNER UPON REQUEST. IT MAY BE SUBJECT TO CERTAIN RESTRICTIONS UNDER APPLICABLE EXPORT CONTROL LAWS AND REGULATIONS.</small>		

TOLERANCES UNLESS OTHERWISE SPECIFIED:			
DEC.	INCH	mm	ANGLE
.X	±0.1	[±2.5]	±7° 30"
.XX	±0.03	[±0.76]	
.XXX	±0.005	[±0.127]	
.XXXX	±0.0005	[±0.0127]	
REMOVE BURRS & BREAK SHARP EDGES: .003/.015 [.076/.381] CORNER FILLETS: .02 [.51] MACHINED SURFACES: 200 INCH/mm 5.1 mm SHOWN IN [BRACKETS]			

DRAWN BY MVG
DATE 07/22/2014
APPROVED BY MVG
DATE 07/22/2014
REFERENCE
THIRD ANGLE PROJECTION

REGAL ™ Regal Beloit America, Inc.	
DESCRIPTION OUTLINE (CUST. NAME: FASCO IND)	
MATERIAL	PROCESS/FINISH
SIZE B	DRAWING NUMBER 5KCP39PGWD71S
SHEET 1 OF 1	