

S.NO	CONNECTION	COLOR	EXIT TYPE	EXIT LOC (VIEWING LE)	GAGE	MATERIAL	WALL THK.	LENGTH	TERMINATION	NAMEPLATE DATA	
										MODEL	5KCP39FGWD70S
1	COMMON LEAD	WHITE	SHELL NOTCH	3:00	18	THERMOPLASTIC	4/64	27.00	.50 BWS	CUST. P/N	D913
2	CAPACITOR LEAD	BRN/WHT	SHELL NOTCH	5:00	18	THERMOPLASTIC	4/64	27.00	.25 FQC	HP	1/4
3	CAPACITOR LEAD	BROWN	SHELL NOTCH	5:00	18	THERMOPLASTIC	4/64	27.00	.25 FQC	RPM	1075
4	HIGH SPEED LEAD	BLACK	SHELL NOTCH	3:00	18	THERMOPLASTIC	4/64	27.00	.50 BWS	VOLTS	460
5	REV LEAD	PURPLE	SHELL NOTCH	5:00	18	THERMOPLASTIC	2/64	5.50	.25 ISQC LO INS FORCE	HZ	60/50
6	REV LEAD	BROWN	SHELL NOTCH	5:00	18	THERMOPLASTIC	2/64	5.50	.25 ISQC LO INS FORCE	SPEEDS	1
7	REV LEAD	ORANGE	SHELL NOTCH	5:00	18	THERMOPLASTIC	2/64	5.50	.25 MALE ISQC	AMPS	1.0
8	REV LEAD	YELLOW	SHELL NOTCH	5:00	18	THERMOPLASTIC	2/64	5.50	.25 MALE ISQC	CAP. REQ'D-D1	5.0 µfd/370 Volts
9	GROUND LEAD	GRN-YEL	CLAMPSCREW	4:30	18	THERMOPLASTIC	2/64	12.50	#10 EYELET	CAP. REQ'D-D2	N/R
										CONN.DRW#	NP24X350357
										ROTATION	CCW/CW (VIEWED FROM LE)

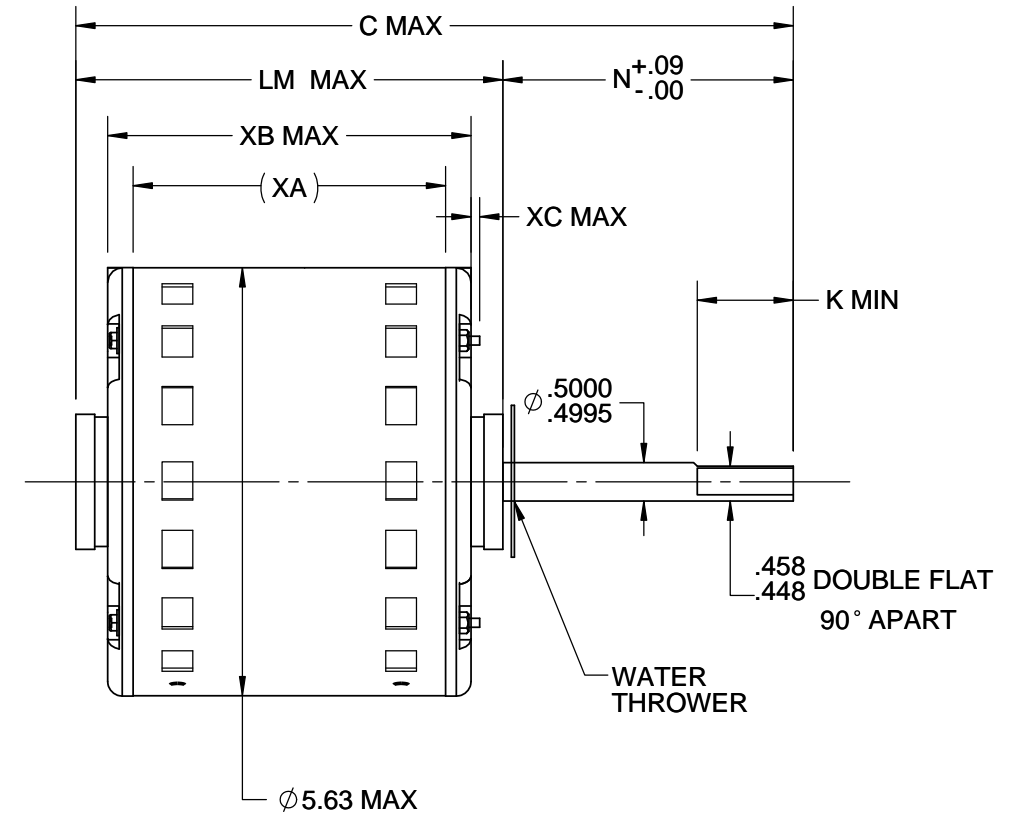
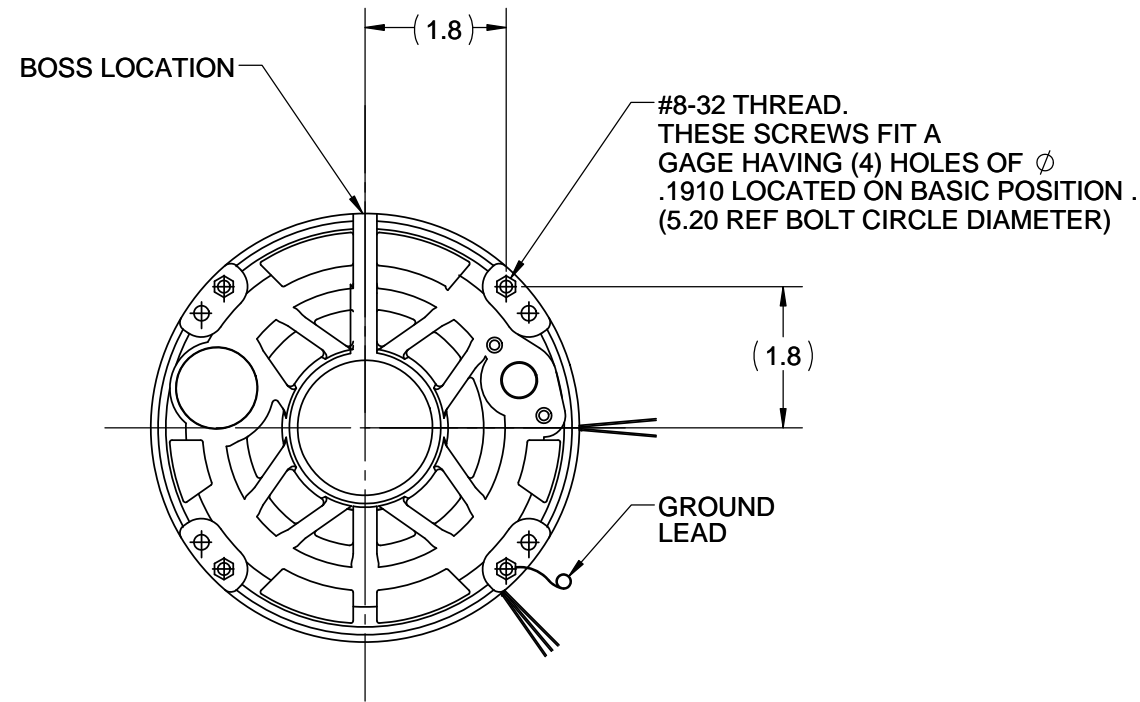

NOTE:

- 1) DIMENSIONS SHOWN ARE NOMINAL UNLESS OTHERWISE SPECIFIED.
- 2) NAME PLATE LABEL LOCATION : 360° - CENTER - READ FROM LE.

	1.00	-
	XC	XD
11.34	5.90	5.37
C	N	K
	5.31	3.82
	XA	4.48
		XB

VENTILATION SYSTEM	
SHELL VENTS	DRIP PROOF
ENDSHIELD (OPP.LEAD END)	CLOSED
ENDSHIELD (LEAD END)	OPEN

DRAWING REVISION D	REVISION BY J. RUPERT	DATE 10-27-2016
ECO ECO-0111878	APPROVED BY J. RUPERT	DATE 10-27-2016
ECO DESCRIPTION CHANGED REVERSING LEADS & CONN. DIAGRAM		
<small>COPYRIGHT REGAL BELOIT AMERICA, INC. ALL RIGHTS RESERVED. PROPRIETARY AND CONFIDENTIAL INFORMATION - THIS DOCUMENT IS THE PROPERTY OF REGAL BELOIT AMERICA, INC. ("OWNER") AND CONTAINS OWNER'S PROPRIETARY INFORMATION. ANY PERSON, CORPORATION OR OTHER FIRM RECEIVING IT IS DEEMED, BY RECEIVING IT, TO AGREE THAT IT, AND/OR ANY PART OF IT, SHALL NOT BE DISCLOSED TO ANY PERSON, CORPORATION OR OTHER ENTITY, DUPLICATED, AND/OR USED, EXCEPT AS EXPRESSLY APPROVED IN WRITING IN ADVANCE BY OWNER. THIS DOCUMENT SHALL BE RETURNED TO OWNER UPON REQUEST. IT MAY BE SUBJECT TO CERTAIN RESTRICTIONS UNDER APPLICABLE EXPORT CONTROL LAWS AND REGULATIONS.</small>		

TOLERANCES UNLESS OTHERWISE SPECIFIED:			
DEC.	INCH	mm	ANGLE
.X	±0.1	[±2.5]	±7° 30"
.XX	±0.03	[±0.76]	
.XXX	±0.005	[±0.127]	
.XXXX	±0.0005	[±0.0127]	
REMOVE BURRS & BREAK SHARP EDGES: .003/.015 [0.076/.381]			
CORNER FILLETS: .02 [0.51]			
MACHINED SURFACES: 200 INCH 5.1 mm			
mm SHOWN IN [BRACKETS]			

DRAWN BY MVG
DATE 07/08/2014
APPROVED BY BN
DATE 07/08/2014
REFERENCE
THIRD ANGLE PROJECTION

REGAL ™ Regal Beloit America, Inc.	
DESCRIPTION OUTLINE (CUST. NAME: FASCO IND)	
MATERIAL	PROCESS/FINISH
SIZE B	DRAWING NUMBER 5KCP39FGWD70S
	SHEET 1 OF 1