

S.NO	CONNECTION	COLOR	EXIT TYPE	EXIT LOC (VIEWING LE)	GAGE	MATERIAL	WALL THK.	LENGTH	TERMINATION
1	COMMON LEAD	WHITE	SHELL NOTCH	4:00	N/R	N/R	N/R	20.00	.50BWS
2	HIGH SPEED LEAD	BLACK	SHELL NOTCH	4:00	N/R	N/R	N/R	20.00	.50BWS
3	HIGH SPEED LEAD	RED	SHELL NOTCH	4:00	N/R	N/R	N/R	20.00	.50BWS
4	GROUND LEAD	GRN-YEL	CLAMPSCREW	7:30	18	THERMOPLASTIC	2/64	3.50	#10 SERR. EYELET

NAMEPLATE DATA	
MODEL	5KCP39HGU789AP
CUST. P/N	MODEL D827
HP	1/8
RPM	700
VOLTS	115
HZ	60
SPEEDS	1
AMPS	2.80
CAP. REQ'D-D1	6.0 µfd/370 Volts
CAP. REQ'D-D2	N/R
CONN.DRW#	NP24X350113
ROTATION	CW (VIEWED FROM LE)

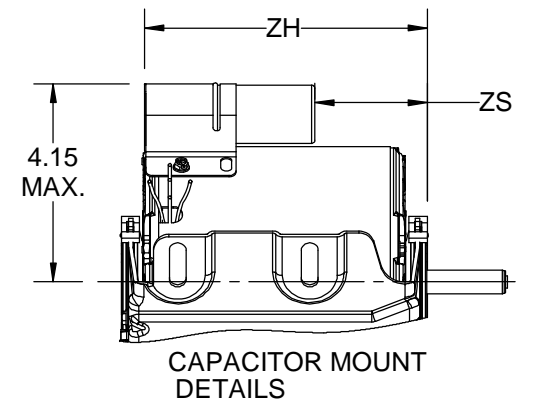
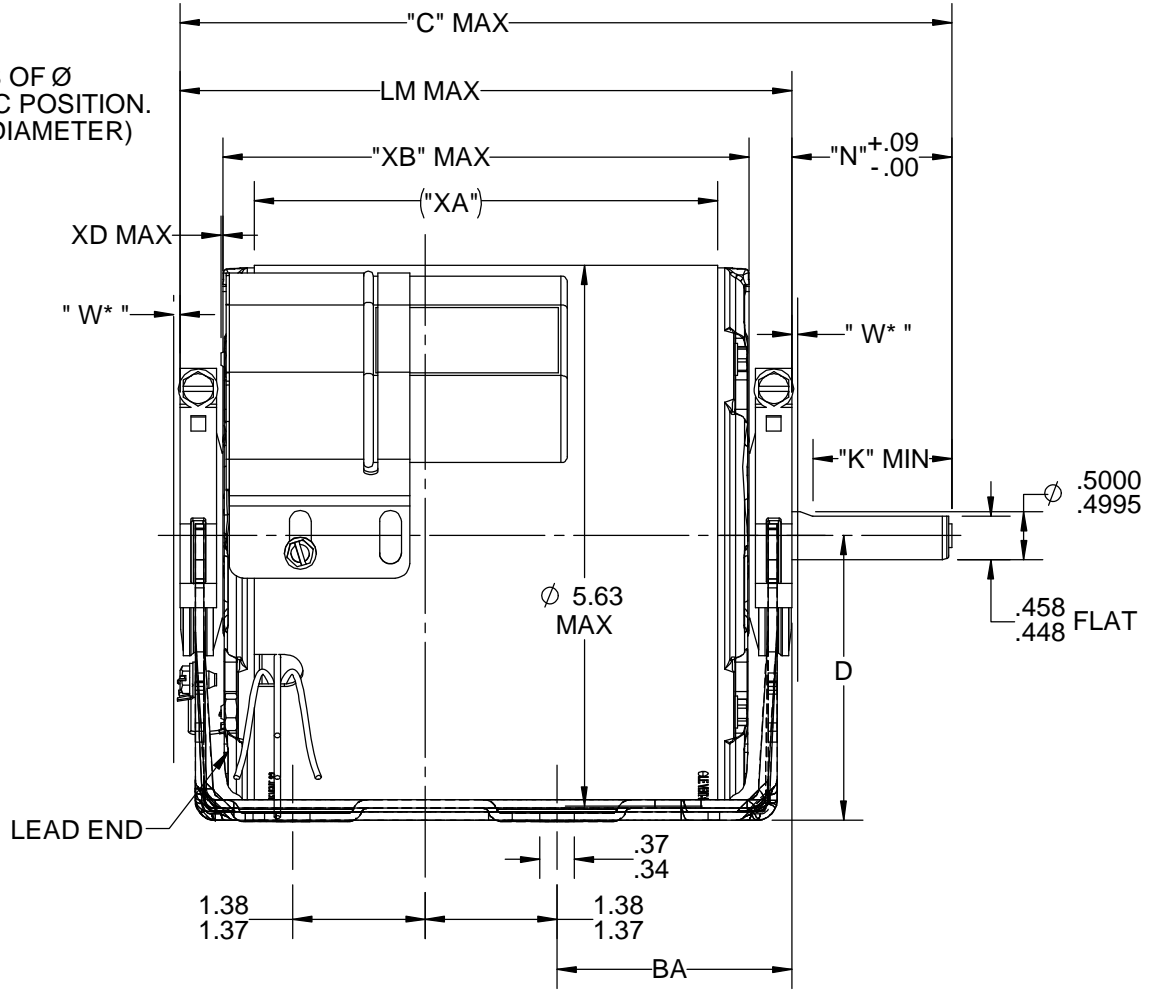
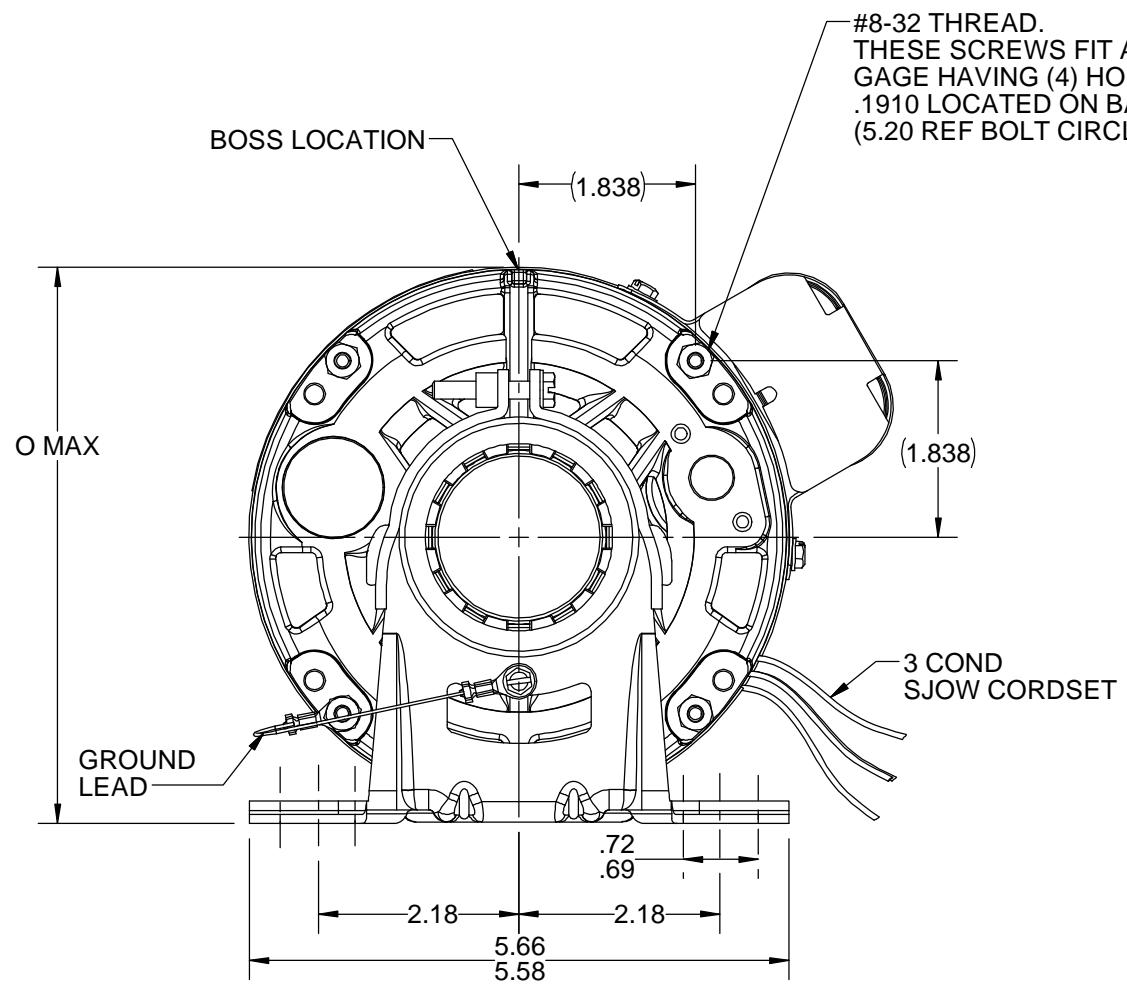

- NOTES:
- 1) DIMENSIONS SHOWN ARE NOMINAL UNLESS OTHERWISE SPECIFIED.
 - 2) NAME PLATE LABEL LOCATION: 315° - CENTER - READ FROM LE WITH RESPECT TO BOSS LOCATION.
 - 3) "W*" IS A VARIABLE CLEARANCE DUE TO VARIATION IN PARTS AND ASSEMBLY.
- "N" MINUS "W" = +.09 TO -.13

5.89	2.38	6.01	3.00	2.50	N/A	N/A	.14
ZH	ZS	O	D	BA	BB	XC	XD
7.89	1.50	1.45	N/A	N/A	6.31	4.82	5.48
C	N	K	XN	XK	LM	XA	XB

NEMA 48 FRAME BASE

VENTILATION SYSTEM	
SHELL VENTS	CLOSED
ENDSHIELD (OPP.LEAD END)	OPEN
ENDSHIELD (LEAD END)	OPEN

DRAWING REVISION A	REVISION BY RS	DATE 10/25/2018
ECO ECO-0146669	APPROVED BY RS	DATE 10/25/2018
ECO DESCRIPTION FILPPED LATCH STRAP SCREWS AS PER ECO		
<small>COPYRIGHT REGAL BELOIT AMERICA, INC. ALL RIGHTS RESERVED. PROPRIETARY AND CONFIDENTIAL INFORMATION - THIS DOCUMENT IS THE PROPERTY OF REGAL BELOIT AMERICA, INC. ("OWNER") AND CONTAINS OWNER'S PROPRIETARY INFORMATION. ANY PERSON, CORPORATION OR OTHER FIRM RECEIVING IT IS DEEMED, BY RECEIVING IT, TO AGREE THAT IT, AND/OR ANY PART OF IT, SHALL NOT BE DISCLOSED TO ANY PERSON, CORPORATION OR OTHER ENTITY, DUPLICATED, AND/OR USED, EXCEPT AS EXPRESSLY APPROVED IN WRITING IN ADVANCE BY OWNER. THIS DOCUMENT SHALL BE RETURNED TO OWNER UPON REQUEST. IT MAY BE SUBJECT TO CERTAIN RESTRICTIONS UNDER APPLICABLE EXPORT CONTROL LAWS AND REGULATIONS.</small>		

DRAWN BY GREG
DATE 02/01/10
APPROVED BY GREG
DATE 02/01/10
REFERENCE
THIRD ANGLE PROJECTION

REGAL ™ Regal Beloit America, Inc.	
DESCRIPTION OUTLINE	
CUST. NAME: (FASCO DISTRIBUTING CO.)	
MATERIAL	PROCESS/FINISH
SIZE B	DRAWING NUMBER 5KCP39HGU789AP
SHEET 1 OF 1	