

20	ADD WATER SLINGER TO MOTOR SHAFT.	KSA 07-27-09	21	CHG LEAD MATERIAL TO PVC.	SMC 10/21/09	22	REVISED PACKING AND ADDED CARTON LABEL NOTES	4004800 MLM 03/06/12	STANDARD TOLERANCES: ANGULAR +/- 1 DEGREE 2 PLACE DECIMAL +/- .01 3 PLACE DECIMAL +/- .005
----	-----------------------------------	--------------	----	---------------------------	--------------	----	--	-------------------------	---

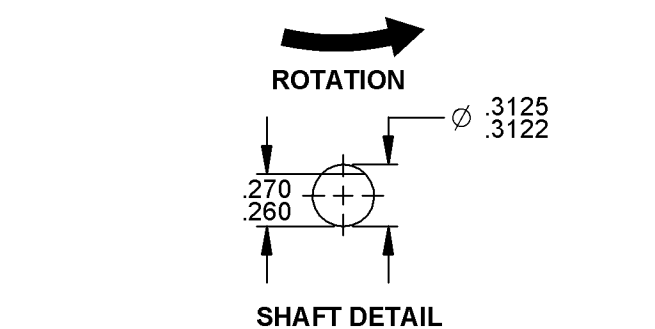
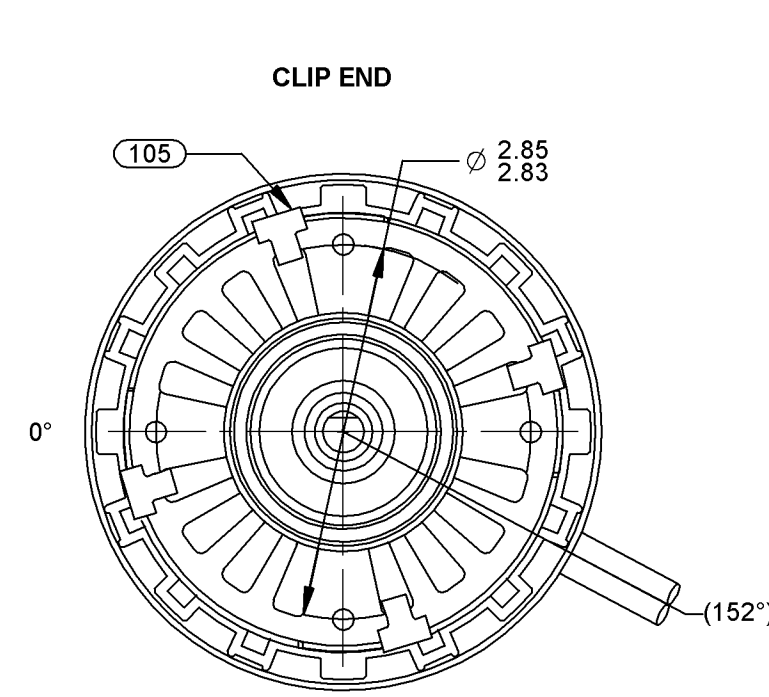
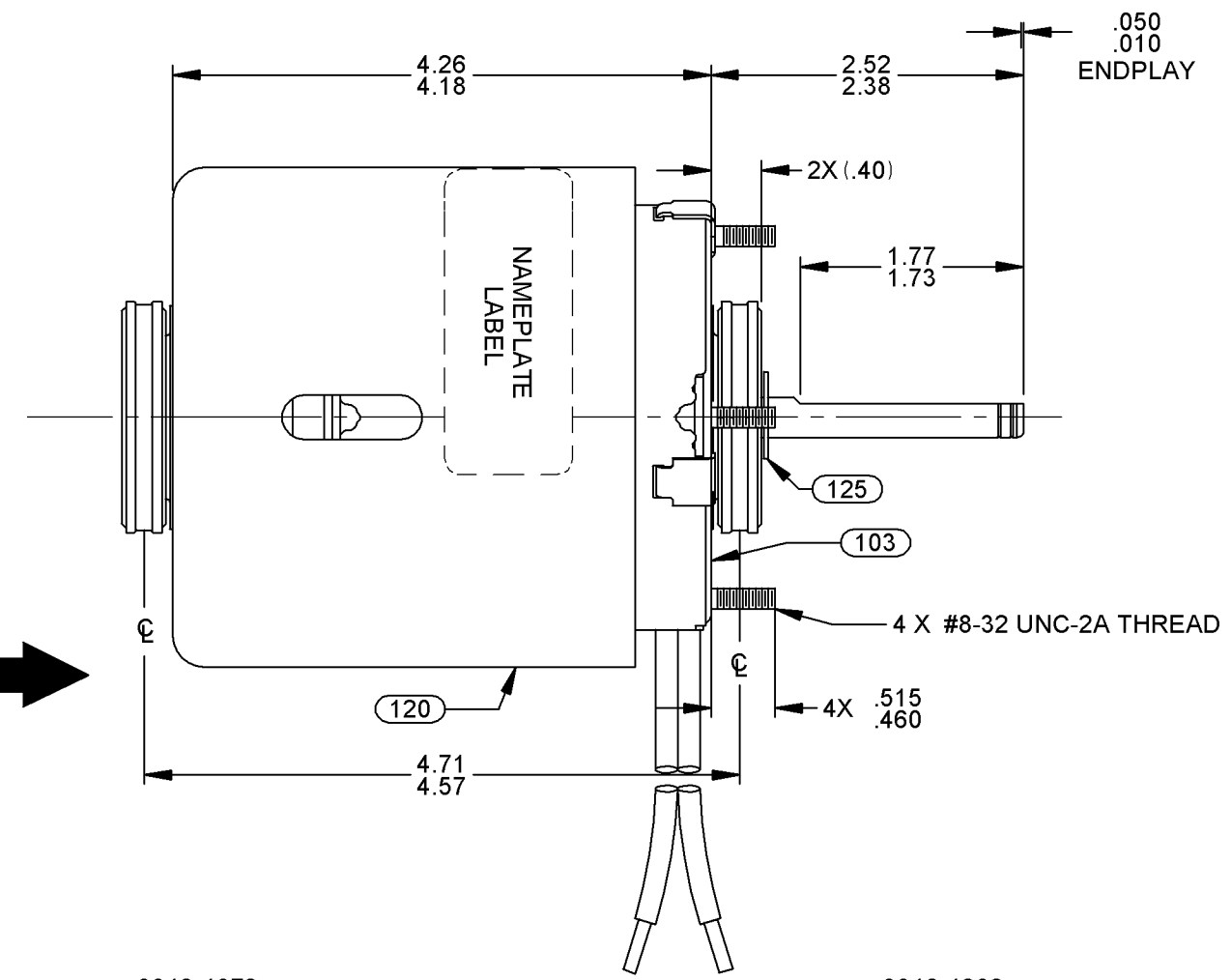
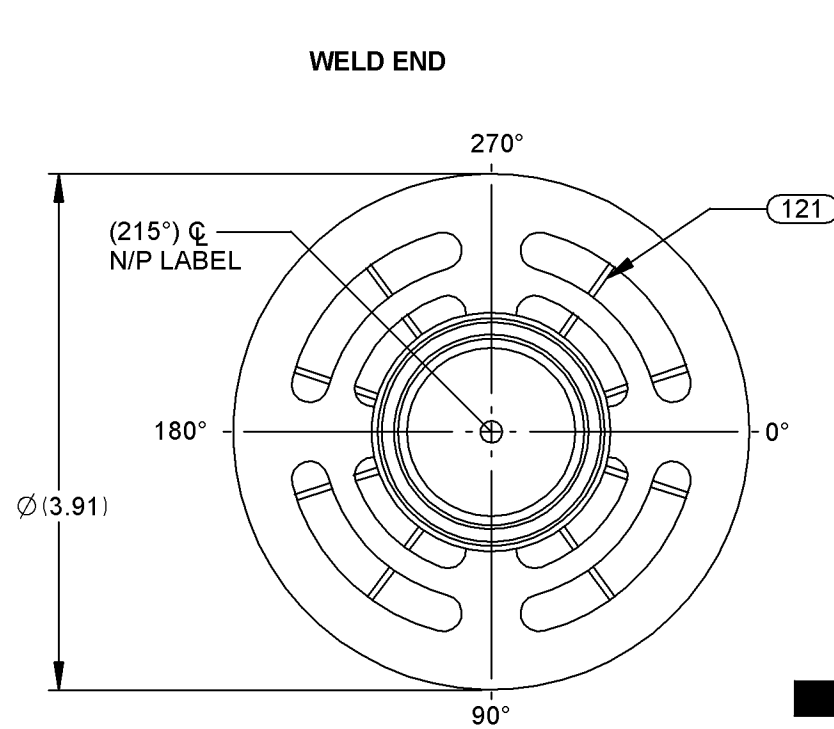

LEAD MATERIAL
18 GA. 105°C 4/64 INSUL.
(2) COND. PARALLEL
PVC, BLACK,
37.00/33.00 IN. LONG
3.25/2.75 IN. RIP
.56/.44 IN. STRIP

0046-4072

0046-4282

FASCO Motor Division

Assembled in Mexico

No. 71637922 TYPE U63B1 T.P. AO

208-230 V 60Hz Class B

1.1 A 1550 RPM 1/20 HP

Model D471 Max Amb: 40°C

LR6319

SAFETY WARNING

This Motor Must Be Grounded in Accordance With Local Or National Electrical Codes To Prevent Possible Injury Due To Electrical Shock

NOTES:
210 MAX. MOTORS PER PALLET.
NO PACKAGING TAPE OVER CARTON LABEL.

FRONT SHAFT POSITION	* TYPICAL PERFORMANCE AT 208-230 VOLTS 60 Hz.												CUSTOMER: FASCO DIST.	FASCO FASCO MOTORS GROUP AC MOTOR/BLOWER DIVISION									
HORIZONTAL DOWN	MOTOR SPEED	IDLE			LOADED			LOCKED			BREAK	PART NUMBER: D471	CONFIDENTIAL: DO NOT DUPLICATE OR DISCLOSE TO THIRD PARTIES WITHOUT WRITTEN PERMISSION OF FASCO MOTORS GROUP, AC MOTOR/BLOWER DIVISION.										
		R.P.M.	AMP.	WATT	IN.OZ.	R.P.M.	AMP.	WATT	IN.OZ.	AMP.	WATT	IN.OZ.	APPLICATION:	MOTOR TYPE				DRAWING NUMBER					
CUSTOMER APPROVAL: SIGNED: DATE:	208 V	1755	.83	83	34.7	1550	.97	126	18.9	1.41	183	41.9	MOTOR WEIGHT: 4.69 POUNDS	SHADED POLE				7163 7922					
	230 V	1760	.94	101	42.6	1550	1.07	156	21.2	1.60	231	52.5	ENVIRONMENT: DRY	FINISH COLOR: BLACK				REV. 22					
														DATE DRAWN: MARCH 20, 2001	B	LA	FR	A	S	C	E	B	A
														00	63	28	V	06	JW	5	3	0	22

If Printed, this is an Uncontrolled Document.