

11	CHANGE NAMEPLATE TO 0046-4072, MOVE WARNING LABEL TO N/P, MOVE LEAD NOTE.	SDM 11/30/07	12	CHANGED LEAD MATERIAL TO PVC.	SMC 10/22/09	13	ADDED PACKING NOTE	4005161 BP 4/04/2012	STANDARD TOLERANCES: ANGULAR +/- 1 DEGREE 2 PLACE DECIMAL +/- .01 3 PLACE DECIMAL +/- .005
----	---	--------------	----	-------------------------------	--------------	----	--------------------	-------------------------	---

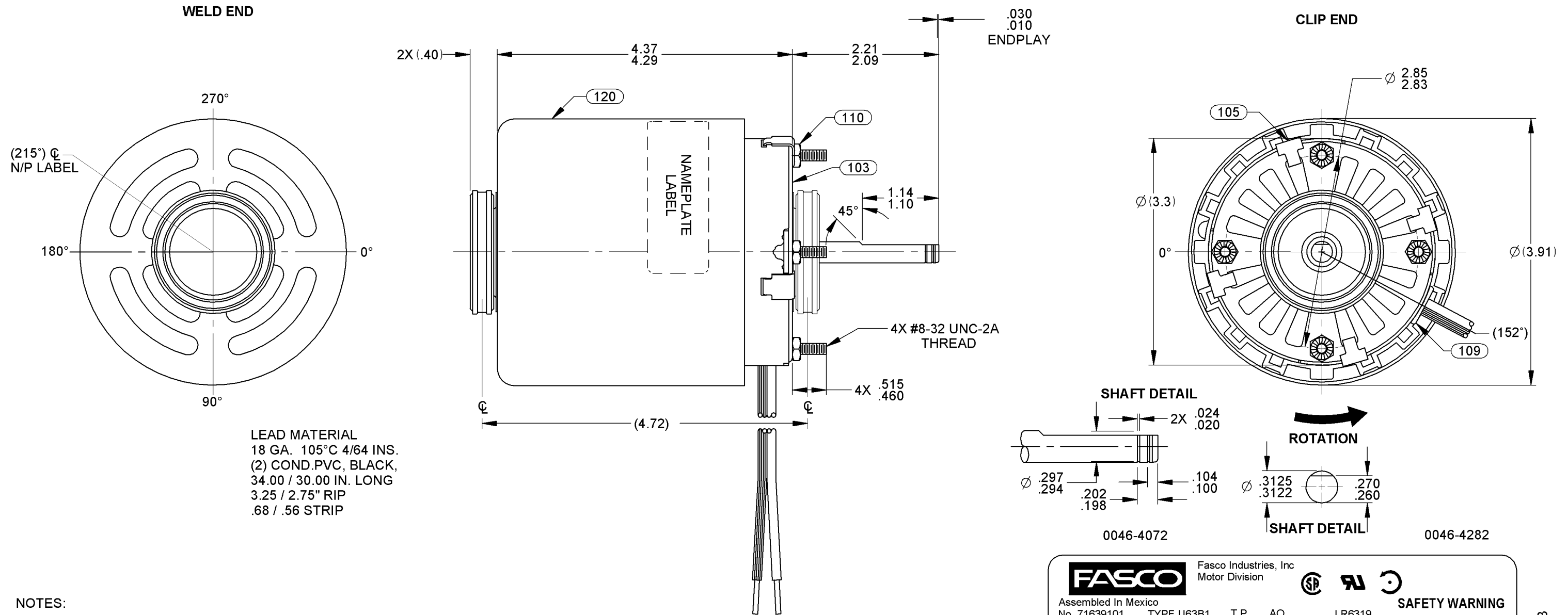

FASCO Fasco Industries, Inc
Motor Division

Assembled In Mexico
No. 71639101 TYPE U63B1 T.P. AO LR6319
208-230 V 60 Hz Class B 1/12 HP
1.3 A 1550 RPM Max Amb:40°C

SAFETY WARNING
This Motor Must Be Grounded in Accordance With Local Or National Electrical Codes To Prevent Possible Injury Due To Electrical Shock

FRONT SHAFT POSITION UP HORIZONTAL DOWN	* TYPICAL PERFORMANCE AT 208-230 VOLTS 60 Hz.												CUSTOMER: FASCO DIST.	FASCO FASCO MOTORS GROUP AC MOTOR/BLOWER DIVISION
	MOTOR SPEED	IDLE			LOADED			LOCKED			BREAK	PART NUMBER: D469		
	R.P.M.	AMP.	WATT	IN.OZ.	R.P.M.	AMP.	WATT	IN.OZ.	AMP.	WATT	IN.OZ.	APPLICATION:	CONFIDENTIAL: DO NOT DUPLICATE OR DISCLOSE TO THIRD PARTIES WITHOUT WRITTEN PERMISSION OF FASCO MOTORS GROUP, AC MOTOR/BLOWER DIVISION.	
	208 V	1772	.87	91	47.0	1550	1.15	157	18.6	1.61	199	48.6	MOTOR WEIGHT: 5.75 POUNDS	
CUSTOMER APPROVAL:													ENVIRONMENT: DRY	
SIGNED:	230 V	1774	.97	109	57.6	1550	1.26	161	20.5	1.81	254	60.5	FINISH COLOR: BLACK	
DATE:													DRAWN BY: S. M. MAGGARD	
													DATE DRAWN: 9-20-2002	
	B	LA	FR	A	S	C	E	B	A	REV. 13				
	00	63	28	V	08	BS	5	3	0					

If Printed, this is an Uncontrolled Document.

61299553