

SAFETY WARNING
This motor must be grounded in accordance with local or national electrical codes to prevent possible injury due to electrical shock

AVERTISSEMENT DE SÉCURITÉ
Ce moteur doit être fondée sur conformément à la réglementation locale ou national électrique codes pour prévenir d'éventuelles blessures en raison de choc électrique

00464072

FASCO Motor Division

Assembled in Mexico

No. 71632745 TYPE U63B1 T.P. AO LR6319

115 V 60 Hz Class B

2.5/1.5 A 1500 RPM 1/14-1/21 HP

Model D366 Max Amb: 40°C

Connection Diagram

Wht — Common
Blk — High
Red — Low
Grn/Yel — Grd

61299553

NOTES:
1. NO PACKAGING TAPE OVER CARTON LABEL

LOCATE IN A CONVENIENT LOCATION TO READ FROM BACK END

CUSTOMER:	FASCO DIST	APPLICATION:	COUNTER SALES								
CUSTOMER PN:	D366	MOTOR WEIGHT:	3.88 LBS.								
	UP	ENVIRONMENT:	DRY								
	MOTOR TYPE SHADED POLE		REFERENCE SAMPLE								
	B	LA	FR								
	00	63	30								
		V	06								
	C	E	B								
	GC	6	3								
	A		0								
TYPICAL PERFORMANCE AT 115 VOLTS 60 HZ											
	IDLE			LOADED			LOCKED			BREAK	
MOTOR SPEED	RPM	AMP	WATT	IN OZ	RPM	AMP	WATT	IN OZ	AMP	WATT	IN OZ
HIGH	1774	2.02	112	45.4	1550	2.28	170	16.0	3.14	252	50.0
LOW	1768	1.24	72	27.3	1560	1.47	109	12.0	2.10	153	33.5

DRAWING REVISION AC	REVISION BY MLS	DATE 1/2/2019	TOLERANCES UNLESS OTHERWISE SPECIFIED: DEC. INCH mm ANGLE	DRAWN BY MLS	REGAL™ Regal Beloit America, Inc.
ECO-0159181	APPROVED BY FDP	DATE 1/2/2019	.X ±0.1 [±2.5] ±1° .XX ±0.01 [±0.25] .XXX ±0.005 [±0.127] .XXXX ±0.0005 [±0.0127]	DATE 7/5/2017	DESCRIPTION OUTLINE MOTOR ASSY
ECO DESCRIPTION ADDED GROUND LEAD LENGTH BACK TO PRINT			REMOVE BURRS & BREAK SHARP EDGES: .003/.015 [078/381] X 45° CORNER FILLETS: R.02 [.51]	APPROVED BY KSA	MATERIAL
COPYRIGHT REGAL BELOIT AMERICA, INC. ALL RIGHTS RESERVED. PROPRIETARY AND CONFIDENTIAL INFORMATION. THIS DOCUMENT IS THE PROPERTY OF REGAL BELOIT AMERICA, INC. FORMER AND CONTAINS OWNERS PROPRIETARY INFORMATION. ANY PERSON, CORPORATION OR OTHER FIRM RECEIVING IT IS DEMAND BY RECEIVING IT, TO AGREE THAT IT, AND/OR ANY PART OF IT, SHALL NOT BE DISCLOSED TO ANY PERSON, CORPORATION OR OTHER ENTITY, DUPLICATED, AND/OR USED, EXCEPT AS EXPRESSLY APPROVED IN WRITING IN ADVANCE BY OWNER. THIS DOCUMENT SHALL BE RETURNED TO OWNER UPON REQUEST. IT MAY BE SUBJECT TO CERTAIN RESTRICTIONS UNDER APPLICABLE EXPORT CONTROL LAWS AND REGULATIONS.			MACHINED SURFACES: .125/32 INCH/mth	DATE 7/5/2017	PROCESS/FINISH BLACK
			THIRD ANGLE PROJECTION	REFERENCE	SIZE [DRAWING NUMBER] C 71632745
				SHEET 1 OF 2	

- NOTES:
1. STAKE STATOR TO MAIN FRAME PER 88830264.
 2. MAXIMUM TORQUE REQUIRED TO TURN MOTOR SHAFT IS 3/8 INCH-OUNCE.
 3. MAKE-UP WASHERS ARE TO BE ADDED OR DELETED TO ACHIEVE REQUIRED ENDPLAY.

BACK END

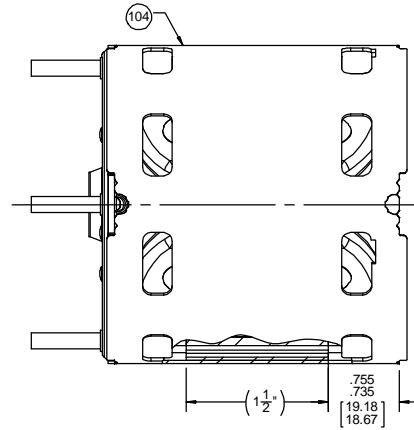

FRONT END

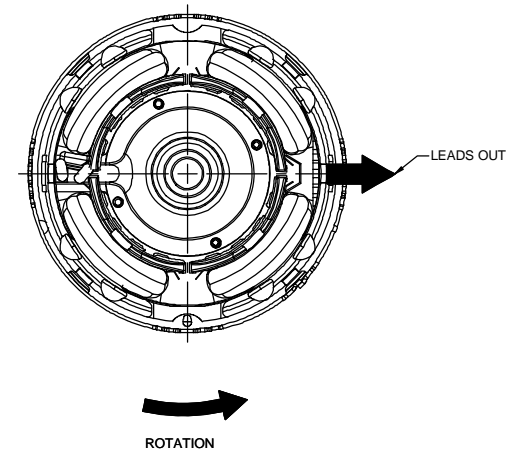

PACKING SPECIFICATIONS

1. PACK 1 PER CONTAINER, 18 CONTAINERS PER LAYER, 6 LAYERS PER PALLET, 108 MAX. PER PALLET, PER 88834200.
2. PLACE FILLER TUBE OVER EACH SHAFT EXTENSION AND PLACE IN CARTON LEADS DOWN, CLOSE FLAPS AND TAPE.
3. CARTON LABELS MUST ALL FACE ONE DIRECTION TOWARD THE OPEN END OF THE PALLET. SEE 88834408.
4. PLACE (1) FLAT PAD ON PALLET, (1) BETWEEN EACH LAYER AND (1) ON TOP. PLACE ALL INSPECTION STICKERS AND WRITING ON TOP FLAT PAD.

DRAWING REVISION AC		REVISION BY MLS	DATE 1/2/2019	TOLERANCES UNLESS OTHERWISE SPECIFIED:		DRAWN BY		Regal Beloit America, Inc.			
ECO-0159181		APPROVED BY FDP	DATE 1/2/2019	DEC.	INCH	mm	ANGLE	DATE 7/5/2017	DESCRIPTION OUTLINE MOTOR ASSY		
ECO DESCRIPTION ADDED GROUND LEAD LENGTH BACK TO PRINT				.XX	±0.1	[±2.5]	±1°	APPROVED BY KSA			
<small>PROPRIETARY AND CONFIDENTIAL INFORMATION. THIS DOCUMENT IS THE PROPERTY OF REGAL BELOIT AMERICA, INC. FORMERLY AND CONTAINS OWNERS PROPRIETARY INFORMATION. ANY PERSON, CORPORATION OR OTHER FIRM RECEIVING IT IS DEEMED BY RECEIVING IT, TO AGREE THAT IT, AND/OR ANY PART OF IT, SHALL NOT BE DISCLOSED TO ANY PERSON, CORPORATION OR OTHER ENTITY, DUPLICATED, AND/OR USED, EXCEPT AS EXPRESSLY APPROVED IN WRITING IN ADVANCE BY OWNER. THIS DOCUMENT SHALL BE RETURNED TO OWNER UPON REQUEST. IT MAY BE SUBJECT TO CERTAIN RESTRICTIONS UNDER APPLICABLE EXPORT CONTROL LAWS AND REGULATIONS.</small>				.XXX	±0.01	[±0.25]		DATE 7/5/2017	MATERIAL		
<small>COPYRIGHT REGAL BELOIT AMERICA, INC. ALL RIGHTS RESERVED.</small>				.XXXX	±0.005	[±0.127]		REFERENCE		PROCESS/FINISH BLACK	
				REMOVE BURRS & BREAK SHARP EDGES: .0031 015 [078/381] X 45°		MACHINED SURFACES: .125/3.2 INCH/milv		THIRD ANGLE PROJECTION	SIZE C	DRAWING NUMBER 71632745	SHEET 2 OF 2
				CORNER FILLETS: R.02 [51]		mm SHOWN IN [BRACKETS]					