

NOTES

1. THRU AIR SPACING BETWEEN WIRE AND METAL .10 MIN.
2. TIE BOLT TOLERANCE 7 - 12 IN. LBS.
3. FOR WASHER SET-UP, SEE CHART C600 0279, DETAIL "A".

ECO	REV.	DATE	SPEC/CHECK
638599	23	9-8-08	LDC/LDC
639443	24	04-13-09	GAE/GAE
4002109	25	05/24/11	MLM/PLA
4011874	26	3/7/2014	NJP/BGP

- A. SEE PACKAGING MANUAL PAGE 2 FOR PACKAGING PROCEDURE.
- 1 MOTOR/CARTON;
10 MOTORS/LAYER;
6 LAYERS/PALLET;
60 MOTORS/PALLET.
- B. SEE DRAWING 87856079 SH. 1 FOR PALLET LAYOUT.
- C. CENTER LABEL, 61229014, ON END OF CARTON.
- D. PLACE PAMPHLET, 61224579, IN CARTON WITH MOTOR.
- E. CARTON LABELS MUST ALL FACE ONE DIRECTION TOWARD THE OPEN END OF THE PALLET. SEE P.S. 88834408.
- F. NO PACKAGING TAPE OVER CARTON LABEL.

71xx xxxx

71xx xxxxC

71xx xxxz

If Printed, this is an Uncontrolled Document

PRODUCTION TEST AT IDLE 230 VOLTS 60 HZ		MOTOR SPEED	PERFORMANCE TEST 230 VOLTS 60 HZ 1 PH 1/15 HP												
AMP	WATT		IDLE			LOADED				LOCKED			BREAK		
			RPM	AMP	WATT	OZ/IN	RPM	AMP	WATT	OZ/IN	AMP	WATT	OZ/IN		
.99	.81	128.7	105.3	HIGH	1172	.9	117	60	1050	1.1	161	24	1.4	204	71
—	—	—	—												
.55	.45	62.7	51.3	MED.	1163	.5	57	27	1050	.5	77	14	.7	95	32
—	—	—	—												
.33	.27	48.4	39.6	LOW	1161	.3	44	21	1050	.4	60	8	.5	73	26
HI-POT TEST 2000 VOLTS															
MAX LEAKAGE CURRENT 5 mA															

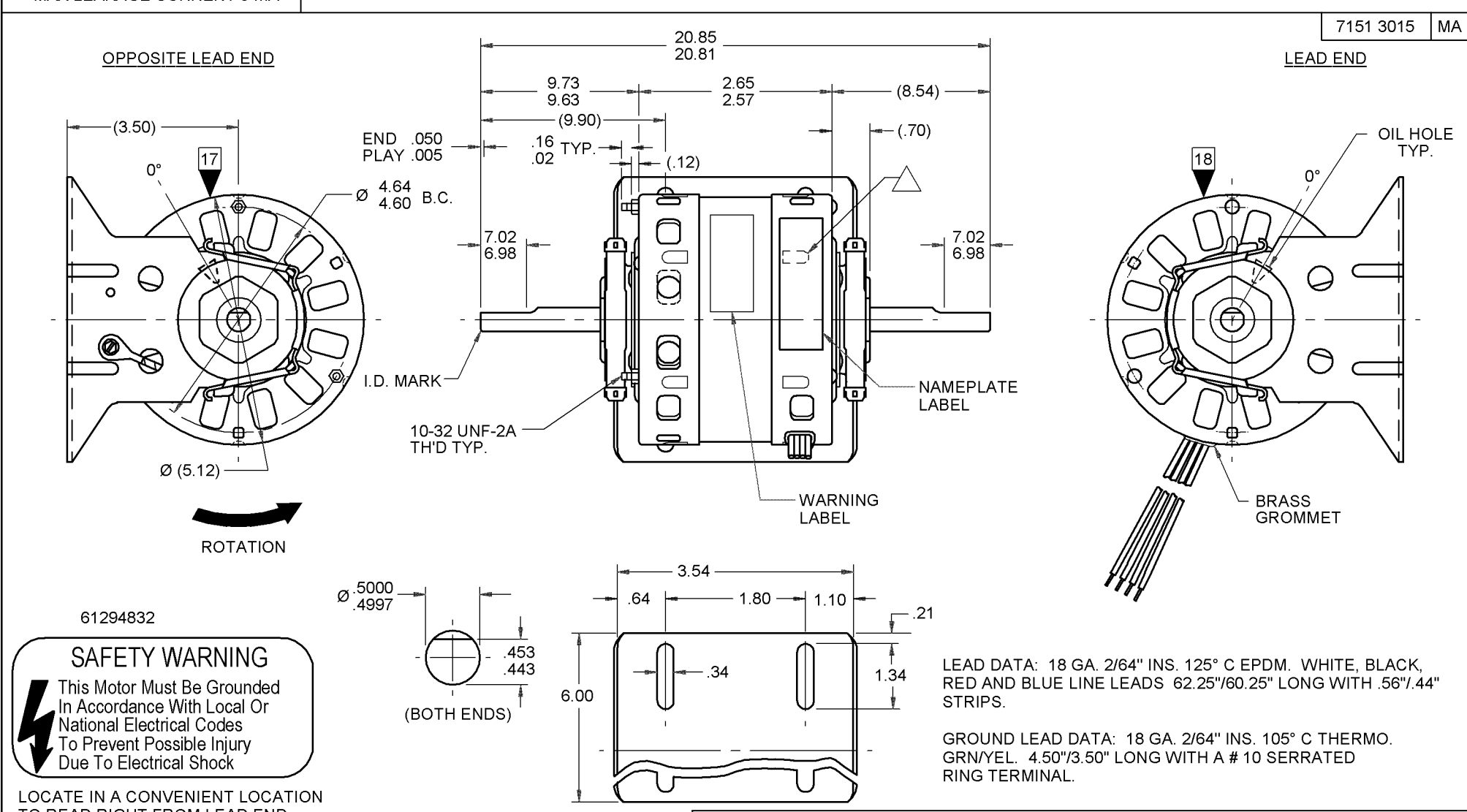

SPECIAL INSTRUCTIONS: SHAFT IS BONDERIZED. FLATS TO BE PARALLEL WITHIN ± 20°. ROTATE MOTOR 120° CWLE IN BASE, AS SHOWN. △ LANCE MUST BE COMPLETELY COVERED BY NAMEPLATE. PAMPHLET PACKED WITH MOTOR.

MOTORS PACKED MAX. PER SKID: PALLET PACK, 60 CARTON PACK, TRAY PACK.	
CUSTOMER: FASCO DISTRIBUTING CO.	PROPRIETARY: DO NOT DUPLICATE OR DISCLOSE TO THIRD PARTIES WITHOUT WRITTEN PERMISSION OF FASCO IND. INC., ELDON MO.
PART NUMBER: D251	FASCO INDUSTRIES, INC. MOTOR DIVISION ELDON PLANT
APPLICATION: DIST. SALES	MOTOR TYPE
FINISH COLOR: GRAY	SHADED POLE
MOTOR WEIGHT: 8.00 LBS.	
ENVIRONMENT: WET	
INSULATION CLASS: A	
	MOTOR NUMBER REV.
	7151 3015 26

00464072 00464516

FASCO Fasco Industries, Inc. Motor Division

Assembled in Mexico No. 71513015 TYPE U51 AO 3 SPD

208/230 V 50/60 Hz 1.2-5-4 A 1050 RPM 1/15-1/35-1/50 HP LR6319

Thermally Protected PH 1 Max Amb: 40°C

CONNECTION DIAGRAM
WHITE — LINE
BLK-HI — LINE
BLUE-MED — LINE
RED-LO — LINE

61299553

8669 6584 2