

06	REMOVE BARCODE, UPDATE N/P & UPDATE TO CURRENT STANDARDS.	KSA 11/12/09	07	ADDED CARTON LABEL NOTES	4002302 MLM 6/8/11	08	UPDATED IDLE AMPS AND WATTS	4010840 PLA 11/22/13	STANDARD TOLERANCES: ANGULAR +/- 1 DEGREE 2 PLACE DECIMAL +/- .01 3 PLACE DECIMAL +/- .005
----	---	--------------	----	--------------------------	-----------------------	----	-----------------------------	-------------------------	---

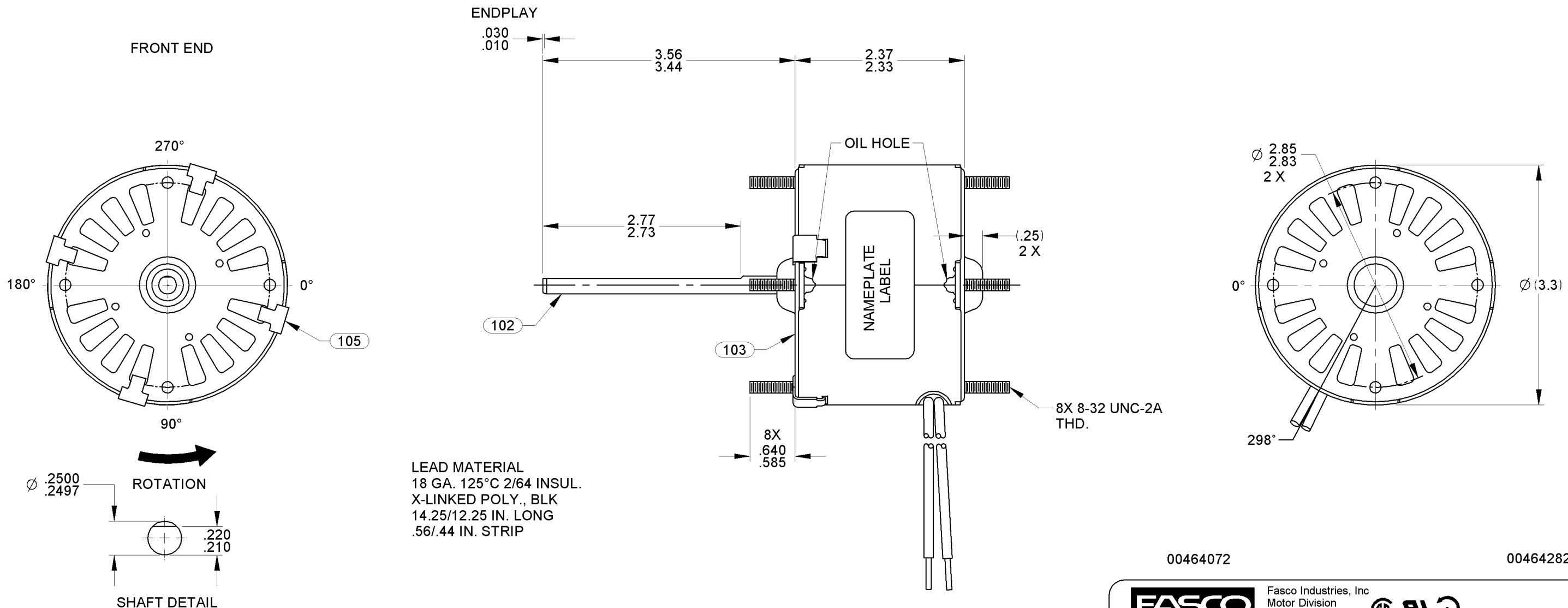

NOTES:  
1. NO PACKAGING TAPE OVER CARTON LABEL.

00464072 00464282

**FASCO** Fasco Industries, Inc  
Motor Division

Assembled In Mexico  
No. 71219956 TYPE U21B T.P. AO  
120 V 60 Hz Class B  
.6 A 3000 RPM

**SAFETY WARNING**  
This Motor Must Be Grounded in Accordance With Local Or National Electrical Codes To Prevent Possible Injury Due To Electrical Shock

1/100 HP  
Max Amb: 40°C

61299553

FRONT SHAFT POSITION	TYPICAL PERFORMANCE AT 120 VOLTS 60 Hz												CUSTOMER: FASCO DIST.		FASCO MOTORS GROUP AC MOTOR/BLOWER DIVISION															
	MOTOR SPEED	IDLE			LOADED			LOCKED			BREAK	PART NUMBER: D229	APPLICATION: AFTER MARKET SALES	CONFIDENTIAL: DO NOT DUPLICATE OR DISCLOSE TO THIRD PARTIES WITHOUT WRITTEN PERMISSION OF FASCO MOTORS GROUP, AC MOTOR/BLOWER DIVISION.					MOTOR TYPE					DRAWING NUMBER						
		R.P.M.	AMP.	WATT	IN.OZ.	R.P.M.	AMP.	WATT	IN.OZ.	AMP.	WATT	IN.OZ.				SHADED POLE					7121 9956									
HORIZONTAL		3345	.64	48.5	4.0	3000	.62	51	2.8	.79	67	5.6																		
CUSTOMER APPROVAL:																														
SIGNED:																														
DATE:																														
																B	LA	FR	A	S	C	E	B	A	REV.					
																00	21	30	V	01	EC	5	1	0	08					

If Printed, this is an Uncontrolled Document.