

NOTES:  
LOCATE WARNING LABEL IN CONVENIENT LOCATION.

61305910

00464296

**SAFETY WARNING**  
This motor must be grounded in accordance with local or national electrical codes to prevent possible injury due to electrical shock.

**AVERTISSEMENT DE SÉCURITÉ**  
Ce moteur doit être fondé sur conformément à la réglementation locale ou national électrique codes pour prévenir d'éventuelles blessures en raison de choc électrique.

Fasco Ind. Inc. Class B  
Assembled in Mexico

No. 71631808 TYPE U63B1 TEAO  
115V 60 Hz 1.7 A 1/25 HP  
1500 RPM T.P.  
Model D222  
Rot: CCWLE LR6319

61299553

CUSTOMER:	FASCO DIST.	APPLICATION:	COUNTER SALES
CUSTOMER PN:	D222	MOTOR WEIGHT:	3.50 LBS
UP		ENVIRONMENT:	DRY
MOTOR TYPE SHADED POLE		REFERENCE SAMPLE	
B	LA	FR	A
00	63	35	T
TYPICAL PERFORMANCE AT 120 VOLTS 60 HZ			
IDLE		LOADED	
MOTOR SPEED	RPM	AMP	WATT
	1750	1.50	79
		1550	1.68
		121	10.5
		2.5	185
		36.0	

DRAWING REVISION AA	REVISION BY FDP	DATE 6/14/2018	TOLERANCES UNLESS OTHERWISE SPECIFIED: DEC. INCH mm ANGLE	DRAWN BY FDP	REGAL™ Regal Beloit America, Inc.
ECO-0146458	APPROVED BY SED	DATE 6/14/2018	.X ±0.1 [2.5] $\pm$ 1° .XX ±0.01 [0.25] .XXX ±0.005 [0.127] .XXXX ±0.0005 [0.0127]	DATE 6/14/2018	DESCRIPTION OUTLINE MOTOR ASSY
CHANGED WARNING LABEL TO AGENCY STANDARDS COPYRIGHT REGAL BELOIT AMERICA, INC. ALL RIGHTS RESERVED. PROPRIETARY AND CONFIDENTIAL INFORMATION. THIS DOCUMENT IS THE PROPERTY OF REGAL BELOIT AMERICA, INC. FORMER AND CONTAINS OWNERS PROPRIETARY INFORMATION. ANY PERSON, CORPORATION OR OTHER FIRM RECEIVING IT IS DEEMED BY RECEIVING IT, TO AGREE THAT IT, AND/OR ANY PART OF IT, SHALL NOT BE DISCLOSED TO ANY PERSON, CORPORATION OR OTHER ENTITY, DUPLICATED, AND/OR USED, EXCEPT AS EXPRESSLY APPROVED IN WRITING IN ADVANCE BY OWNER. THIS DOCUMENT SHALL BE RETURNED TO OWNER UPON REQUEST. IT MAY BE SUBJECT TO CERTAIN RESTRICTIONS UNDER APPLICABLE EXPORT CONTROL LAWS AND REGULATIONS.			REMOVE BURRS & BREAK SHARP EDGES: .003/.015 [0.076/.381] X 45° CORNER FILLETS: R.02 [.51] MACHINED SURFACES: .125/ 3/2 INCH/ mm SHOWN IN [BRACKETS]	REFERENCE 6/14/2018	MATERIAL PROCESS/FINISH BLACK
			THIRD ANGLE PROJECTION	SIZE C	DRAWING NUMBER 71631808
					SHEET 1 OF 2

NOTES:

1. STAKE STATOR TO SLEEVE PER 88830264.
2. MAXIMUM TORQUE REQUIRED TO TURN MOTOR SHAFT IS 3/8 INCH-OUNCE.
3. MAKE-UP WASHERS ARE TO BE ADDED OR DELETED TO ACHIEVE REQUIRED ENDPPLAY.
4. DRILL PILOT HOLE WITH A #37 DRILL, .300/.275 [7.620/6.985] DEEP AT CENTER OF DRILL AND PIN COOLING BAND SECURLEY TO THE STATOR/MAIN FAME, 2 PLACES 180° APART.

FRONT END

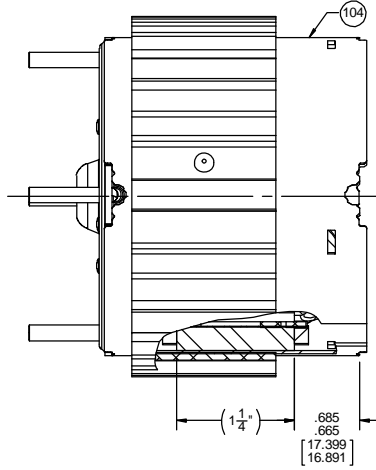

BACK END

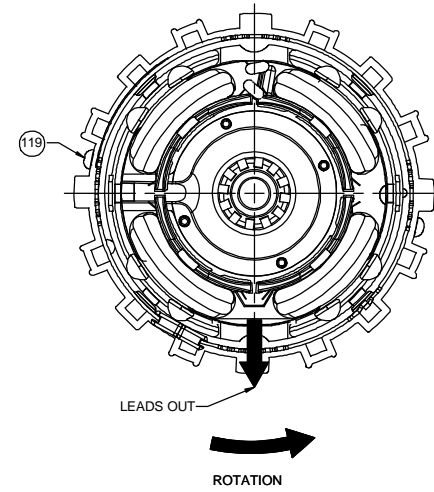

PACKING SPECIFICATIONS

1. PACK 1 PER CONTAINER, 168 PER PALLET. 24 CARTONS PER LAYER, 7 LAYERS PER PALLET.
2. PLACE FILLER TUBE ON EACH END OF SHAFT EXTENSION. PLACE MOTOR IN CARTON, LEADS DOWN STUFF, PAPER AROUND MOTOR TO PREVENT MOVEMENT DURING SHIPMENT, CLOSE FLAPS AND TAPE. CARTON LABELS MUST FACE ONE DIRECTION TOWARD OPEN END OF PALLET. PER 88834408.
3. NO PACKING TAPE OVER CARTON LABEL.
4. PLACE FLAT PAD ON PALLET, (1) BETWEEN EACH LAYER, & (1) ON TOP.

DRAWING REVISION AA		REVISION BY FDP	DATE 6/14/2018	TOLERANCES UNLESS OTHERWISE SPECIFIED: DEC. INCH mm ANGLE		DRAWN BY FDP		 Regal Beloit America, Inc.	
ECO-0146458		APPROVED BY SED	DATE 6/14/2018	.X ±0.1 [±2.5] ±1°	DATE 6/14/2018		DESCRIPTION <b>OUTLINE</b>		
ECO DESCRIPTION CHANGED WARNING LABEL TO AGENCY STANDARDS				.XX ±0.01 [±0.25]	APPROVED BY SED		MATERIAL		
<small>                     PROPRIETARY AND CONFIDENTIAL INFORMATION. THIS DOCUMENT IS THE PROPERTY OF REGAL BELOIT AMERICA, INC. OWNERS AND CONTAINS OWNERS PROPRIETARY INFORMATION. ANY PERSON, CORPORATION OR OTHER FIRM RECEIVING IT IS DEEMED BY RECEIVING IT, TO AGREE THAT IT, AND/OR ANY PART OF IT, SHALL NOT BE DISCLOSED TO ANY PERSON, CORPORATION OR OTHER ENTITY, DUPLICATED, AND/OR USED, EXCEPT AS EXPRESSLY APPROVED IN WRITING IN ADVANCE BY OWNER. THIS DOCUMENT SHALL BE RETURNED TO OWNER UPON REQUEST. IT MAY BE SUBJECT TO CERTAIN RESTRICTIONS UNDER APPLICABLE EXPORT CONTROL LAWS AND REGULATIONS.                 </small>				.XXX ±0.005 [±0.127]	DATE 6/14/2018		PROCESS/FINISH BLACK		
				.XXXX ±0.0005 [±0.0127]	REFERENCE		SIZE DRAWING NUMBER		
				REMOVE BURRS & BREAK SHARP EDGES. .003/.015 [0.076/.381] X 45° CORNER FILLETS: R.02 [.51]	THIRD ANGLE PROJECTION		71631808		
				MACHINED SURFACES: .125/ 3.2 INCH/ mm SHOWN IN [BRACKETS]	SHEET		2 OF 2		