

S.NO	CONNECTION	COLOR	EXIT TYPE	EXIT LOC (VIEWING LE)	GAGE	MATERIAL	WALL THK.	LENGTH	TERMINATION
1	COMMON LEAD	WHITE	SHELL NOTCH	03:00	18	THERMOPLASTIC	4/64	27.00	.50 BWS
2	HIGH SPEED LEAD	BLACK	SHELL NOTCH	03:00	18	THERMOPLASTIC	4/64	27.00	.50 BWS
3	CAPACITOR LEAD	BROWN	SHELL NOTCH	03:00	18	THERMOPLASTIC	4/64	27.00	.25 FQC
4	CAPACITOR LEAD	BRN/WHT	SHELL NOTCH	03:00	18	THERMOPLASTIC	4/64	27.00	.25 FQC
5	REV LEAD	PURPLE	SHELL NOTCH	03:00	18	THERMOPLASTIC	2/64	7.00	.25 ISQC LO INS FORCE
6	REV LEAD	BROWN	SHELL NOTCH	03:00	18	THERMOPLASTIC	2/64	7.00	.25 ISQC LO INS FORCE
7	REV LEAD	ORANGE	SHELL NOTCH	03:00	18	THERMOPLASTIC	2/64	7.00	.25 MALE ISQC
8	REV LEAD	YELLOW	SHELL NOTCH	03:00	18	THERMOPLASTIC	2/64	7.00	.25 MALE ISQC
9	GROUND LEAD	GRN-YEL	CLAMPSCREW	04:30	18	THERMOPLASTIC	2/64	12.00	#10 SERR EYELET

NAMEPLATE DATA	
MODEL	5KCP39SGWD68S
CUST. P/N	D1710
HP	1
RPM	1075
VOLTS	460
HZ	60
SPEEDS	1
AMPS	3.00
CAP. REQ'D-D1	15.00 µfd/370 Volts
CAP. REQ'D-D2	N/R
CONN.DRW#	NP24X350357
ROTATION	CCW/CW (VIEWED FROM LE)

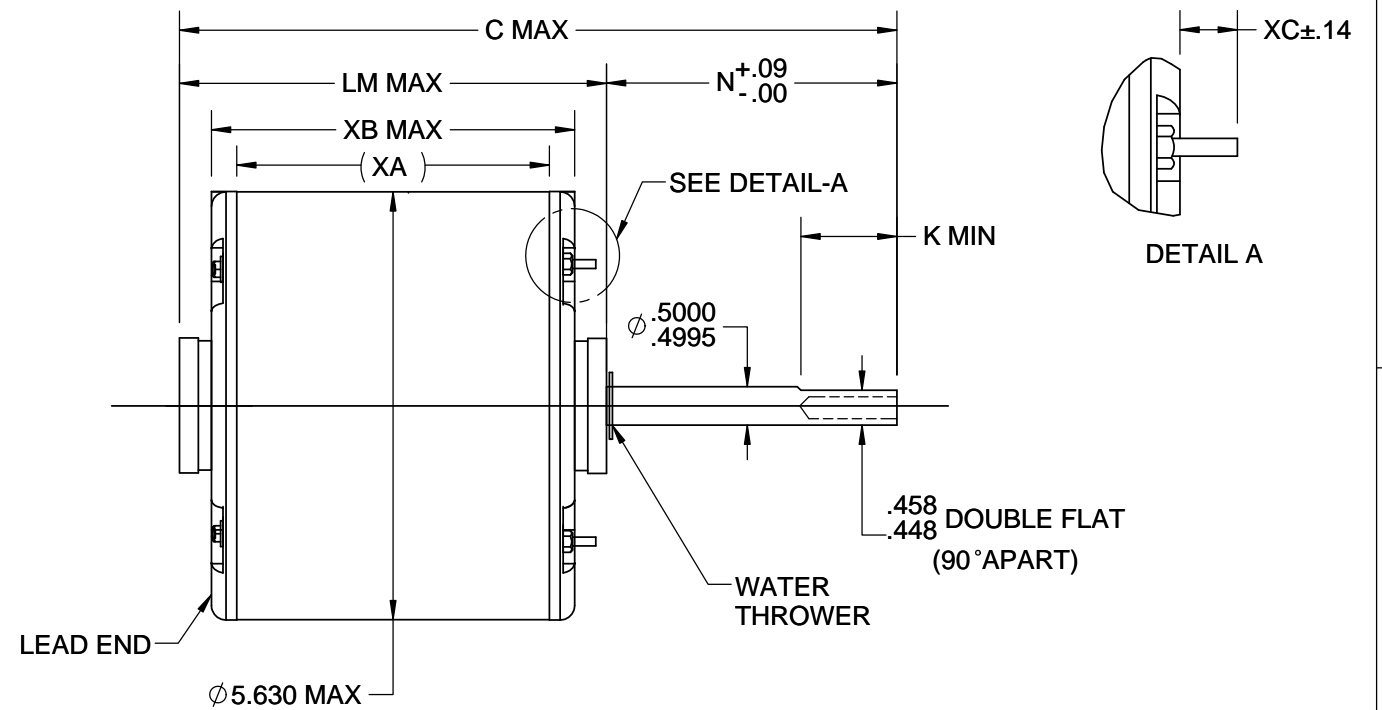
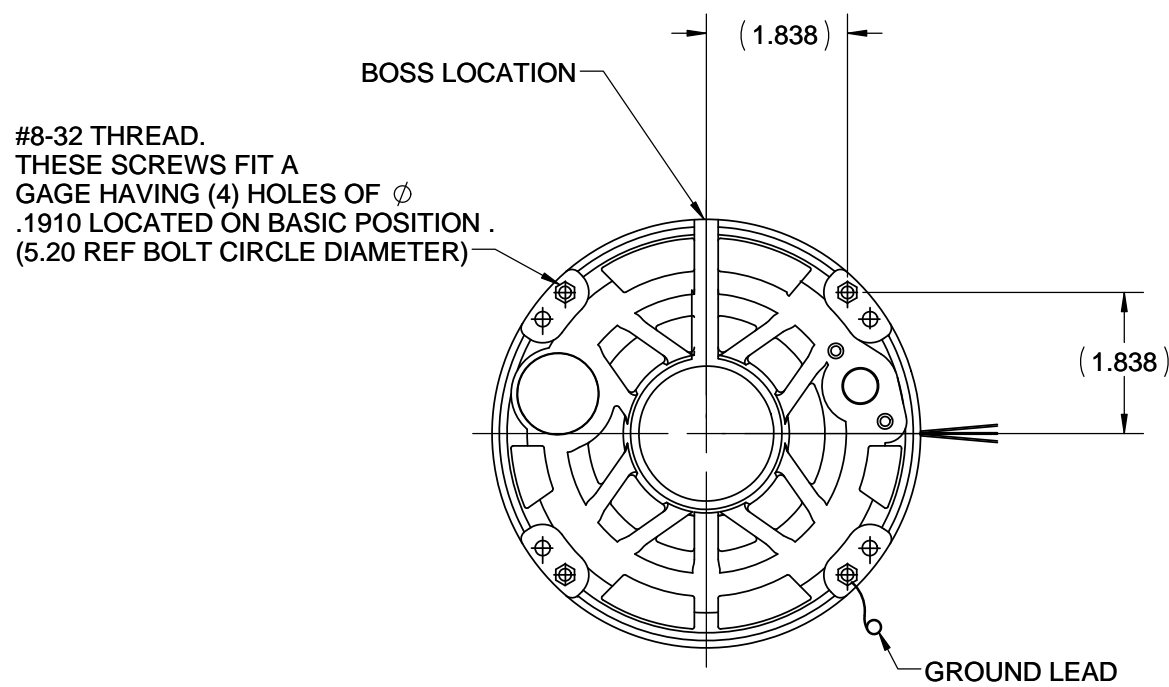

NOTE:

- 1) DIMENSIONS SHOWN ARE NOMINAL UNLESS OTHERWISE SPECIFIED.
- 2) NAME PLATE LABEL LOCATION : 360° - CENTER - READ FROM LE.

VENTILATION SYSTEM	
SHELL VENTS	CLOSED
ENDSHIELD (OPP.LEAD END)	CLOSED
ENDSHIELD (LEAD END)	OPEN

DRAWING REVISION C	REVISION BY MVN	DATE 10-27-16
ECO ECO-0111795	APPROVED BY SH	DATE 10-27-16
ECO DESCRIPTION UPDATED REV LEAD COLOURS PER ECO		
<small>COPYRIGHT REGAL BELOIT AMERICA, INC. ALL RIGHTS RESERVED.                  PROPRIETARY AND CONFIDENTIAL INFORMATION - THIS DOCUMENT IS THE PROPERTY OF REGAL BELOIT AMERICA, INC. ("OWNER") AND CONTAINS OWNER'S PROPRIETARY INFORMATION. ANY PERSON, CORPORATION OR OTHER FIRM RECEIVING IT IS DEEMED, BY RECEIVING IT, TO AGREE THAT IT, AND/OR ANY PART OF IT, SHALL NOT BE DISCLOSED TO ANY PERSON, CORPORATION OR OTHER ENTITY, DUPLICATED, AND/OR USED, EXCEPT AS EXPRESSLY APPROVED IN WRITING IN ADVANCE BY OWNER. THIS DOCUMENT SHALL BE RETURNED TO OWNER UPON REQUEST. IT MAY BE SUBJECT TO CERTAIN RESTRICTIONS UNDER APPLICABLE EXPORT CONTROL LAWS AND REGULATIONS.</small>		

TOLERANCES UNLESS OTHERWISE SPECIFIED:		
DEC.	INCH	mm
.X	±0.1	[±2.5]
.XX	±0.01	[±0.25]
.XXX	±0.005	[±0.127]
.XXXX	±0.0005	[±0.0127]
REMOVE BURRS & BREAK SHARP EDGES: .003/.015 [0.076/.381]		
CORNER FILLETS: .02 [0.51]		
MACHINED SURFACES: 125 INCH 3.2 mm		
mm SHOWN IN [BRACKETS]		

DRAWN BY SSB
DATE 07/04/2014
APPROVED BY MVN
DATE 07/04/2014
REFERENCE
THIRD ANGLE PROJECTION

<b>REGAL</b> ™ Regal Beloit America, Inc.	
DESCRIPTION <b>OUTLINE</b> (CUST. NAME: DEF PUR)	
MATERIAL	PROCESS/FINISH
SIZE B	DRAWING NUMBER 5KCP39SGWD68S
SHEET 1 OF 1	

13.14	6.00	5.20	7.06	1.68	-
C	N	K	LM	XC	XD
				5.57	6.23
				XA	XB