

- NOTES:
1. STAKE STATOR TO MAIN FRAME PER 88830264.
 2. MAXIMUM TORQUE REQUIRED TO TURN MOTOR SHAFT IS 3/8 INCH-OUNCE.
 3. MAKE-UP WASHERS ARE TO BE ADDED OR DELETED TO ACHIEVE REQUIRED ENDPLAY.

FRONT END

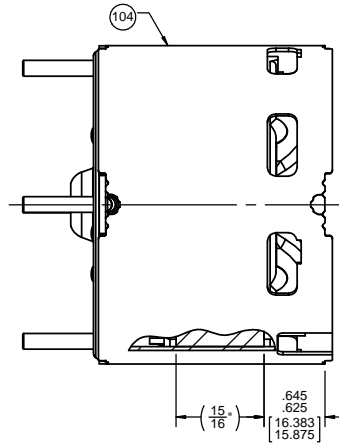

BACK END

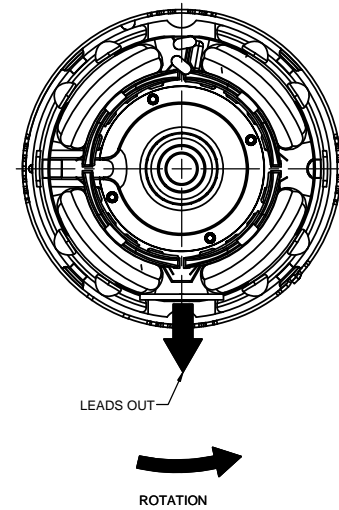

PACKING SPECIFICATIONS

1. PACK 1 PER CARTON, 162 MAX. PER PALLET, PACKING ASSY. 88834200.
2. PLACE ONE FILLER TUBE ON EACH SHAFT EXTENSION, PLACE MOTOR IN CARTON LEADS DOWN, CLOSE FLAPS AND TAPE. PLACE LABEL ON END OF CARTON. LAY CARTON ON SIDE ON PALLET, 27 CARTONS PER LAYER. PLACE ONE FLAT PAD ON PALLET, ONE BETWEEN EACH LAYER AND ONE ON TOP.
3. CARTON LABELS MUST ALL FACE ON DIRECTION TOWARD THE OPEN END OF THE PALLET. SEE 88834408.

DRAWING REVISION AT		REVISION BY MLS	DATE 12/12/2016	TOLERANCES UNLESS OTHERWISE SPECIFIED: DEC. INCH mm ANGLE		DRAWN BY MLS	 Regal Beloit America, Inc.	
ECO-0114636		APPROVED BY KSA	DATE 12/12/2016	.X ±0.1 [±.25] ±1°	.XX ±0.01 [±0.25]	DATE 12/12/2016		
ECO DESCRIPTION UPDATED PACKING ON BOM		COPYRIGHT REGAL BELOIT AMERICA, INC. ALL RIGHTS RESERVED. PROPRIETARY AND CONFIDENTIAL INFORMATION - THIS DOCUMENT IS THE PROPERTY OF REGAL BELOIT AMERICA, INC. FORMERLY AND CONTAINS OWNER'S PROPRIETARY INFORMATION. ANY PERSON, CORPORATION OR OTHER FIRM RECEIVING IT IS DEEMED, BY RECEIVING IT, TO AGREE THAT IT, AND/OR ANY PART OF IT, SHALL NOT BE DISCLOSED TO ANY PERSON, CORPORATION OR OTHER ENTITY, DUPLICATED, AND/OR USED, EXCEPT AS EXPRESSLY APPROVED IN WRITING IN ADVANCE BY OWNER. THIS DOCUMENT SHALL BE RETURNED TO OWNER UPON REQUEST. IT MAY BE SUBJECT TO CERTAIN RESTRICTIONS UNDER APPLICABLE EXPORT CONTROL LAWS AND REGULATIONS.		.XXX ±0.005 [±0.127]	.XXXX ±0.0005 [±0.0127]	APPROVED BY KSA		DESCRIPTION MOTOR ASSY
				REMOVE BURRS & BREAK SHARP EDGES: .003/.015 [0.076/.381] X 45°	CORNER FILLETS: R.02 [S1]	DATE 12/12/2016		MATERIAL
				MACHINED SURFACES: 1.25/3.2	mm SHOWN IN [BRACKETS]	REFERENCE	PROCESS/FINISH BLACK	
						THIRD ANGLE PROJECTION	SIZE DRAWING NUMBER 71631944	
							SHEET 2 OF 2	