

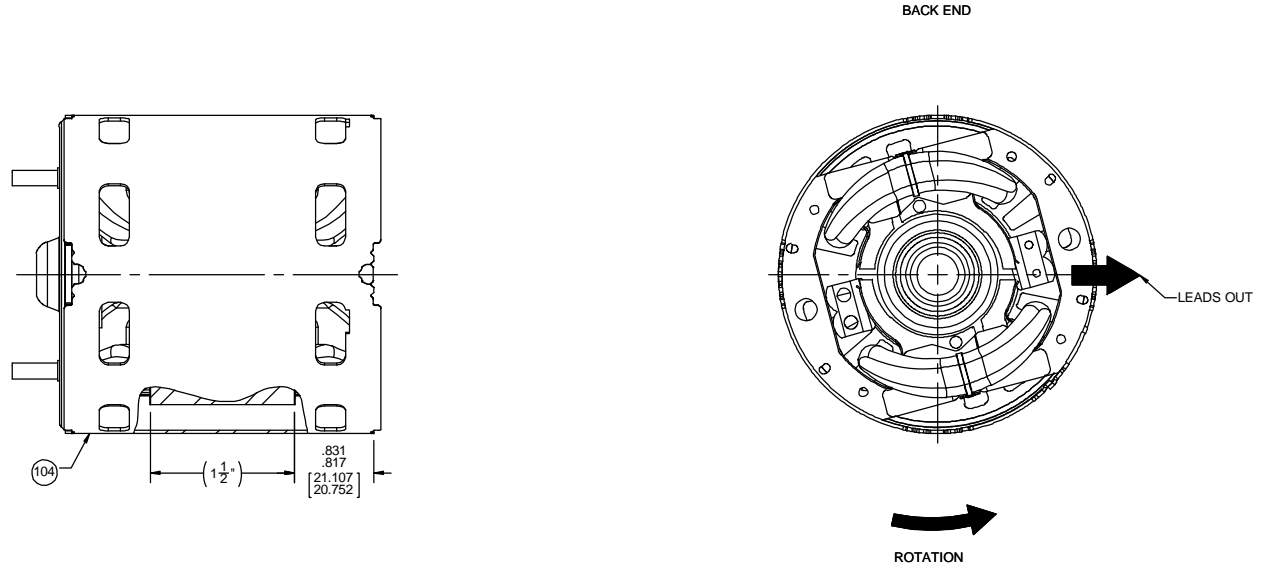

NOTES:

1. ALL SPACING THRU AIR BETWEEN WIRE AND METAL MUST BE AT LEAST: .063 [1.600].
2. ASSEMBLE LOADING SPRING BETWEEN WASHER AND BEARING ON BACK END WITH SPRING FINGERS TOWARD BEARING.
3. ASSEMBLE BALL BEARINGS TO BEARING RETAINERS PER 88834419.



**SWITCH INSTRUCTIONS**

1. ASSEMBLE SWITCH ASSEMBLY AND ACTUATOR PER 88834261.
2. PRESS ACTUATOR ASSEMBLY AND THIMBLE ON SHAFT SO THAT TOP OF METAL ACTUATOR PLATE IS .568/ .548 [14.427/13.919] FROM END OF SHAFT.
3. SWITCH MUST BE ADJUSTED TO OBTAIN .035/ .025 [.889/.635] AIR GAP BETWEEN THIMBLE AND SWITCH IN FULL OPERATING POSITION.
4. SWITCH MUST MAKE CONTACT BETWEEN 1800-2500 RPM AS SPEED INCREASES AND BREAK 50-500 RPM BELOW ACTUAL MAKE.
5. SWITCH MECHANISM TO GIVE QUIET OPERATION ABOVE 2500 RPM.
6. WHEN ASSEMBLING HEYCO, NO SLACK ALLOWED INSIDE SWITCH COVER.

**PACKING SPECIFICATIONS**

1. PACK 1 PER CONTAINER, 36 CONTAINERS PER LAYER, 7 LAYERS PER PALLET, 252 MAX. PER PALLET, PACKING ASSY. 87854526, PER 88834200 AND 88834408.
2. CARTON LABELS MUST ALL FACE ONE DIRECTION TOWARD THE OPEN END OF THE PALLET. SEE 88834408.

DRAWING REVISION AA	REVISION BY MLS	DATE 8/14/2018	TOLERANCES UNLESS OTHERWISE SPECIFIED: DEC. INCH mm ANGLE	DRAWN BY MLS	 Regal Beloit America, Inc.		
ECO ECO-0150657	APPROVED BY SDM	DATE 8/14/2018	.X ±0.1 [±2.5] 1° .XX ±0.01 [±0.25] .XXX ±0.005 [±0.127] .XXXX ±0.0005 [±0.0127]	DATE 8/14/2018			
ECO DESCRIPTION UPDATED SAFETY WARNING LABEL COPYRIGHT REGAL BELOIT AMERICA, INC. ALL RIGHTS RESERVED.			REMOVE BURRS & BREAK SHARP EDGES: .003/.015 [0.076/.381] X 45° CORNER FILLETS: R.02 [.51]	APPROVED BY SDM	DESCRIPTION <b>OUTLINE MOTOR ASSY</b>		
<small>PROPRIETARY AND CONFIDENTIAL INFORMATION. THIS DOCUMENT IS THE PROPERTY OF REGAL BELOIT AMERICA, INC. FORMERLY AND CONTAINS OWNERS PROPRIETARY INFORMATION. ANY PERSON, CORPORATION OR OTHER FIRM RECEIVING IT IS DEEMED BY RECEIVING IT, TO AGREE THAT IT, AND/OR ANY PART OF IT, SHALL NOT BE DISCLOSED TO ANY PERSON, CORPORATION OR OTHER ENTITY, DUPLICATED, AND/OR USED, EXCEPT AS EXPRESSLY APPROVED IN WRITING IN ADVANCE BY OWNER. THIS DOCUMENT SHALL BE RETURNED TO OWNER UPON REQUEST. IT MAY BE SUBJECT TO CERTAIN RESTRICTIONS UNDER APPLICABLE EXPORT CONTROL LAWS AND REGULATIONS.</small>			MACHINED SURFACES: 125/ 3.2 INCH/ mmv	DATE 8/14/2018	MATERIAL	PROCESS/FINISH BLACK	
			THIRD ANGLE PROJECTION	REFERENCE	SIZE C	DRAWING NUMBER <b>71219728</b>	SHEET 2 OF 2