

LEAD MATERIAL  
18 GA. 125°C 2/64 INSUL.  
X-LINKED POLY.  
BLACK  
13.00/11.00 [330.2/279.4]  
W/LEAF TERM.  
AMP 3-61668-1  
TERM. HSG.  
AMP 640136-2  
GROUND LEAD MATERIAL  
GRN/YEL  
9.00/8.00 [228.6/203.2]  
W/RING TERM.  
AMP 41333

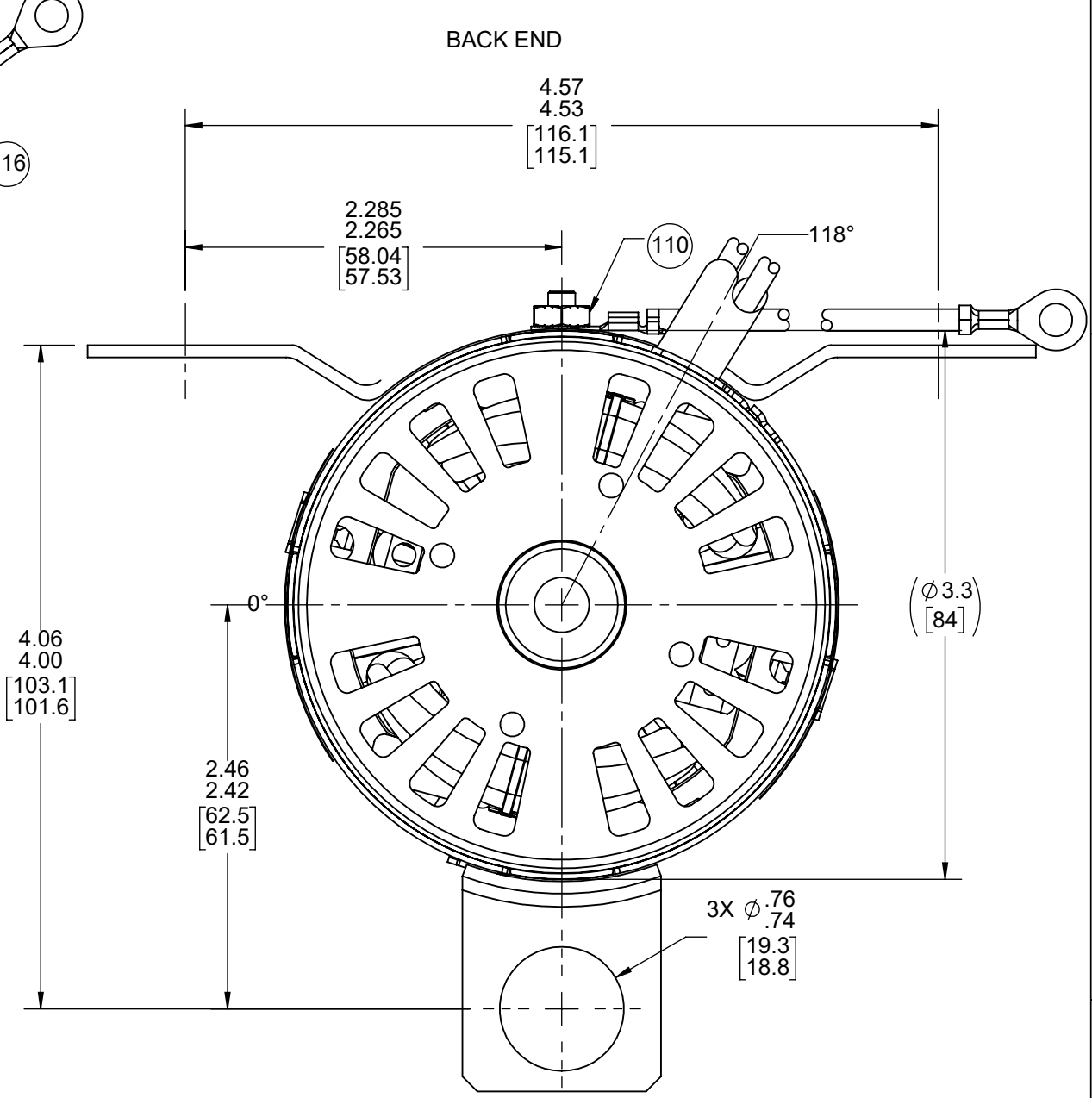
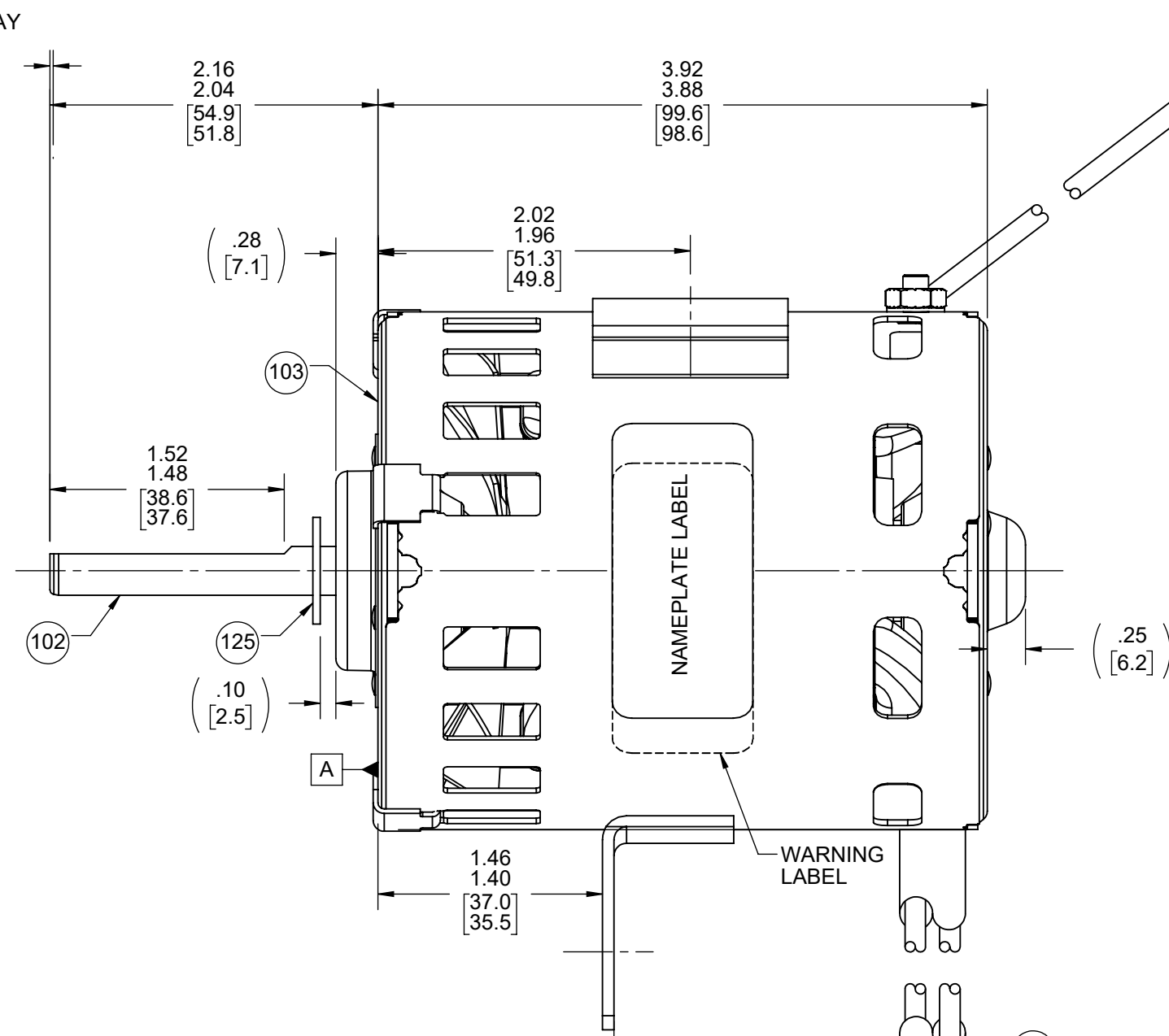

- NOTES:  
1. MOTOR HAS 416 SS SHAFT.  
2. NO PACKAGING TAPE OVER CARTON LABEL.  
3. MOTOR MUST START AT 100 VOLTS.

61305568

00464071

**SAFETY WARNING**  
This motor must be grounded in accordance with local or national electrical codes to prevent possible injury due to electrical shock

**AVERTISSEMENT DE SÉCURITÉ**  
Ce moteur doit être fondée sur conformément à la réglementation locale ou national électrique codes pour prévenir d'éventuelles blessures en raison de choc électrique

**FASCO™**

Assembled In Mexico  
No. 71219953 TYPE U21B T.P. AO  
115 V 60 Hz Class B  
1.5 A 3300 RPM 1/20 HP  
Model D1180 Max Amb: 40°C  
LR6319

CUSTOMER:	FASCO DIST.	APPLICATION:	COUNTER SALES				
CUSTOMER PN:	D1180	MOTOR WEIGHT:					
		ENVIRONMENT:	DAMP				
MOTOR TYPE		REFERENCE SAMPLE					
SHADED POLE							
B	LA	FR	A				
00	21	33	F				
S							
06							
C	E	B	A				
OX	5	3	0				
TYPICAL PERFORMANCE AT 115 VOLTS 60 HZ							
MOTOR SPEED	IDLE		LOADED		LOCKED		BREAK
	RPM	WATT	IN OZ	RPM	WATT	IN OZ	IN OZ
3515	1.29	79.7	13.7	3300	1.5	105	18.7

DRAWING REVISION	REVISION BY	REV DATE/DATE	TOLERANCES (EXCEPT AS NOTED):	DRAWN BY		Regal Beloit America, Inc.
AD	PLA	4/26/2022	DEC. INCH mm ANGLE	MLS		
REQUEST NUMBER	APPROVED BY	DATE	.X ±0.1 [±3]	DATE	DESCRIPTION	
ECR-0217318	KKM	4/26/2022	.XX ±0.01 [±0.3]	2/5/2019	OUTLINE	
REQUEST NUMBER	UPDATED N/P AND BORDER LOGOS		.XXX ±0.005 [±0.13]	APPROVED BY	MOTOR ASSY	
DESCRIPTION	COPYRIGHT (PER REVISION DATE) REGAL BELOIT AMERICA, INC. ALL RIGHTS RESERVED. PROPRIETARY AND CONFIDENTIAL INFORMATION - THIS DOCUMENT IS THE PROPERTY OF REGAL BELOIT AMERICA, INC. ('OWNER') AND CONTAINS OWNER'S PROPRIETARY INFORMATION. ANY PERSON, CORPORATION OR OTHER FIRM RECEIVING IT IS DEEMED, BY RECEIVING IT, TO AGREE THAT IT, AND/OR ANY PART OF IT, SHALL NOT BE DISCLOSED TO ANY PERSON, CORPORATION OR OTHER ENTITY, DUPLICATED, AND/OR USED, EXCEPT AS EXPRESSLY APPROVED IN WRITING IN ADVANCE BY OWNER. THIS DOCUMENT SHALL BE RETURNED TO OWNER UPON REQUEST. IT MAY BE SUBJECT TO CERTAIN RESTRICTIONS UNDER APPLICABLE EXPORT CONTROL LAWS AND REGULATIONS.		.XXXX ±0.0005 [±0.013]	SDM	PROCESS/FINISH	
			REMOVE BURRS & BREAK SHARP EDGES: .003/.015 [ .08/.38] X 45°	DATE	BLACK	
			CORNER FILLETS: R.02 [ .5]	2/5/2019	DRAWING NUMBER	
			MACHINED SURFACES: .125/ mm 3.2 INCH mm	REFERENCE	71219953	
			mm DIMENSIONS IN [BRACKETS] ARE FOR REFERENCE ONLY	MATERIAL	SHEET	
				THIRD ANGLE PROJECTION	1 OF 2	

NOTES:

- 1. ALL SPACING THRU AIR BETWEEN WIRE AND METAL MUST BE AT LEAST: .063 [.160].
- 2. ASSEMBLE PC 151 TUBING OVER LEADS, THEN ASSEMBLE PC 148 TERMINAL HOUSING. ALL TO BE DONE AFTER STATOR PRESS.
- 3. WARNING: MOTOR LEADS MUST BE 13.00/11.00 [330.2/279.4] FROM MAIN FRAME TO END OF TERMINAL HOUSING.

BACK END

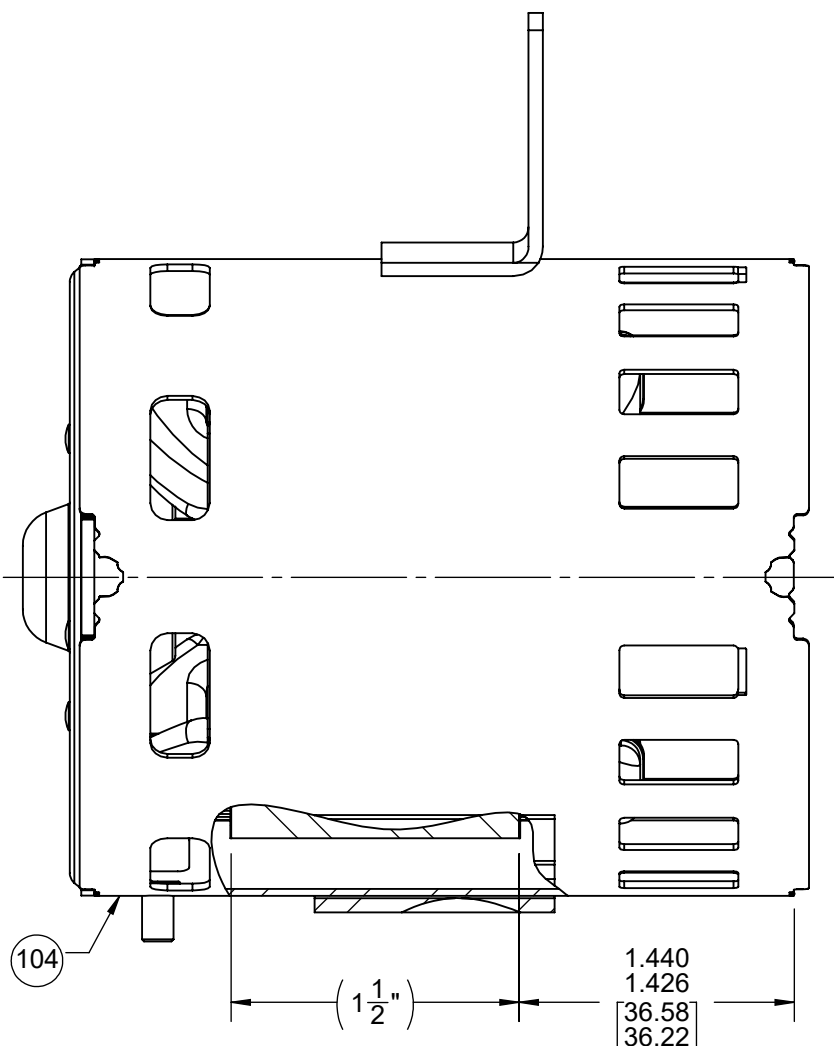

FRONT END

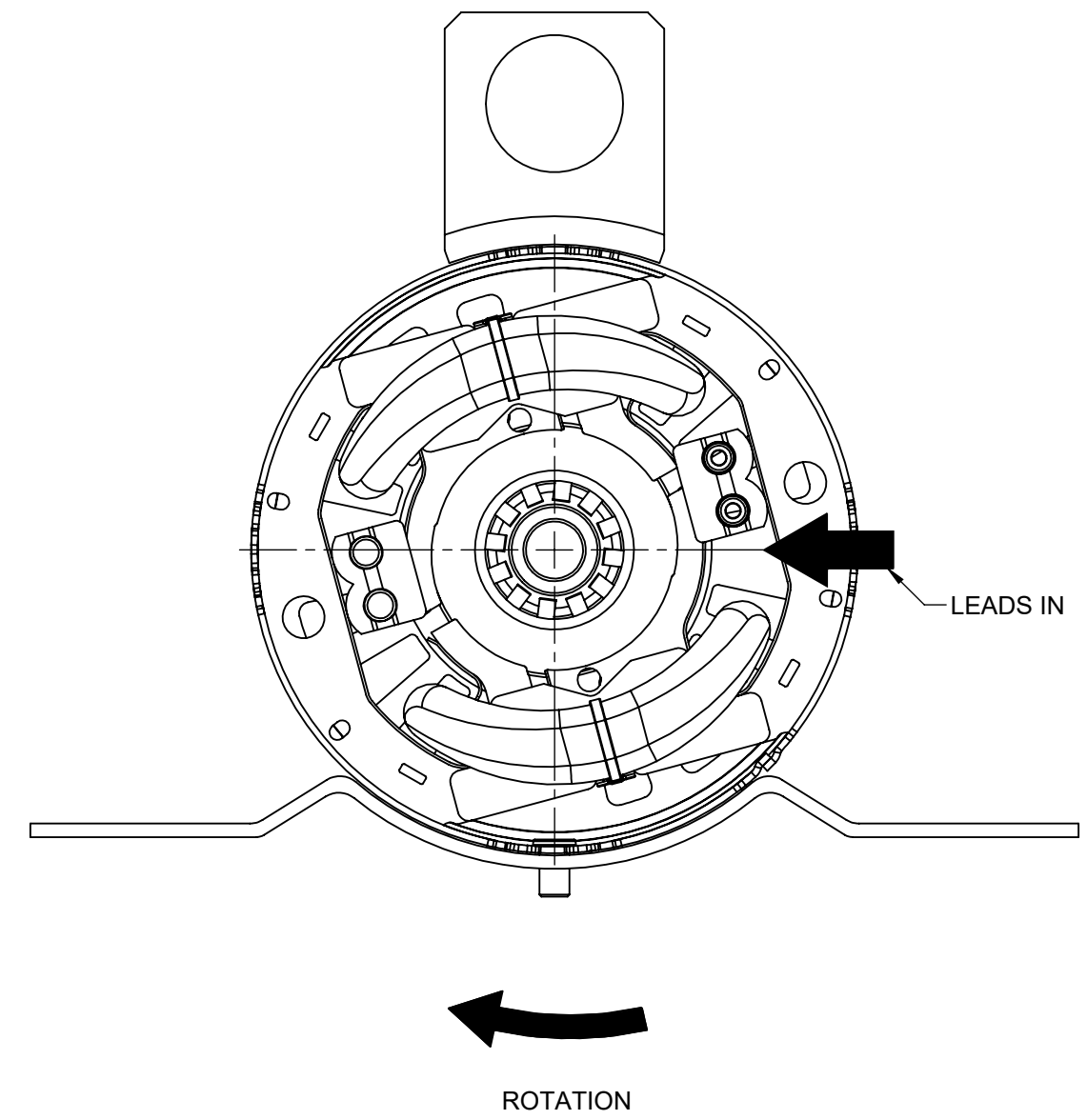

PACKING SPECIFICATIONS

- 1. PACK 1 PER CONTAINER, 42 CONTAINERS PER LAYER, 3 LAYERS PER PALLET, 126 MAX. PACK ASSY. 87854000, PER 88834200 AND 88834408.
- 2. CARTON LABELS MUST ALL FACE ONE DIRECTION TOWARD THE OPEN END OF THE PALLET. SEE 88834408.

DRAWING REVISION AD	REVISION BY PLA	REV DATE/DATE 4/26/2022	TOLERANCES (EXCEPT AS NOTED): DEC. INCH mm ANGLE	DRAWN BY MLS	<b>Regal Rexnord</b> Regal Beloit America, Inc.
REQUEST NUMBER ECR-0217318	APPROVED BY KKM	DATE 4/26/2022	.X ±0.1 [±3] ±1° .XX ±0.01 [±0.3] .XXX ±0.005 [±0.13] .XXXX ±0.0005 [±0.013]	DATE 2/5/2019	
REQUEST NUMBER DESCRIPTION UPDATED N/P AND BORDER LOGOS			REMOVE BURRS & BREAK SHARP EDGES: .003/.015 [.08/.38] X 45° CORNER FILLETS: R.02 [.5] MACHINED SURFACES: .125/ mm 3.2/ INCH mm	APPROVED BY SDM	DESCRIPTION OUTLINE MOTOR ASSY
COPYRIGHT (PER REVISION DATE) REGAL BELOIT AMERICA, INC. ALL RIGHTS RESERVED. PROPRIETARY AND CONFIDENTIAL INFORMATION - THIS DOCUMENT IS THE PROPERTY OF REGAL BELOIT AMERICA, INC. ("OWNER") AND CONTAINS OWNER'S PROPRIETARY INFORMATION. ANY PERSON, CORPORATION OR OTHER FIRM RECEIVING IT IS DEEMED, BY RECEIVING IT, TO AGREE THAT IT, AND/OR ANY PART OF IT, SHALL NOT BE DISCLOSED TO ANY PERSON, CORPORATION OR OTHER ENTITY, DUPLICATED, AND/OR USED, EXCEPT AS EXPRESSLY APPROVED IN WRITING IN ADVANCE BY OWNER. THIS DOCUMENT SHALL BE RETURNED TO OWNER UPON REQUEST. IT MAY BE SUBJECT TO CERTAIN RESTRICTIONS UNDER APPLICABLE EXPORT CONTROL LAWS AND REGULATIONS.			mm DIMENSIONS IN [BRACKETS] ARE FOR REFERENCE ONLY	DATE 2/5/2019	MATERIAL
				REFERENCE	PROCESS/FINISH BLACK
				THIRD ANGLE PROJECTION	SIZE C DRAWING NUMBER 71219953 SHEET 2 OF 2