

LEAD MATERIAL
18 GA. 105°C 4/64 INSUL.
TERMOPLASTIC, 2-COND.
PARALLEL, BLACK

- NOTES:
1. 405 MOTORS MAXIMUM PER PALLET.
2. NO PACKAGING TAPE OVER CARTON LABEL.

CUSTOMER:	FASCO DIST.	APPLICATION:					
CUSTOMER PN:	D1152	MOTOR WEIGHT:	3.19 LBS.				
		ENVIRONMENT:	DRY				
HORIZONTAL	MOTOR TYPE		REFERENCE SAMPLE				
	SHADED POLE						
UP	B	LA	FR				
	00	63	30				
DOWN	A	S	C				
	V	05	OH				
	E	B	A				
	5	3	0				
TYPICAL PERFORMANCE AT 115 VOLTS 60/50 HZ							
MOTOR SPEED	IDLE		LOADED		LOCKED		BREAK
	RPM	AMP	WATT	IN OZ	RPM	AMP	WATT
60 Hz	1767	1.45	81	33.0	1550	1.68	123
							12.0
							2.45
							179
							39.5
50 Hz	1454	1.89	104	35.7	1300	1.96	141
							16.5
							2.85
							222
							50.0

SAFETY WARNING
This motor must be grounded in accordance with local or national electrical codes to prevent possible injury due to electrical shock

AVERTISSEMENT DE SÉCURITÉ
Ce moteur doit être fondée sur conformément à la réglementation locale ou national électrique codes pour prévenir d'éventuelles blessures en raison de choc électrique

00464071

FASCO Fasco Industries, Inc. Motor Division

Assembled in Mexico

No. 71635122 TYPE U63B1 TP. AO LR6319

115V 60/50 Hz Class B

2.1 A 1500/1300 RPM

Model D1152 1/20 HP Max. Amb. 40°C

61299553

DRAWING REVISION AH	REVISION BY SDM	DATE 10/19/2015	TOLERANCES UNLESS OTHERWISE SPECIFIED: DEC. INCH mm ANGLE .X ±0.1 [±2.5] ±1° .XX ±0.01 [±0.25] .XXX ±0.005 [±0.127] .XXXX ±0.0005 [±0.0127]	DRAWN BY SDM	DATE 10/19/2015	REGAL Regal Beloit America, Inc.
ECO DESCRIPTION ECO-0084443	APPROVED BY KSA	DATE 10/19/2015	REMOVE BURRS & BREAK SHARP EDGES: .003/.015 [0.076/.381] X 45° CORNER FILLETS: R.02 [51] MACHINED SURFACES: 125/3.2 INCH/mm	DATE 10/19/2015	APPROVED BY KSA	DESCRIPTION MOTOR ASSY
<small>COPYRIGHT REGAL BELOIT AMERICA, INC. ALL RIGHTS RESERVED. PROPRIETARY AND CONFIDENTIAL INFORMATION - THIS DOCUMENT IS THE PROPERTY OF REGAL BELOIT AMERICA, INC. (OWNER) AND CONTAINS OWNER'S PROPRIETARY INFORMATION. ANY PERSON, CORPORATION OR OTHER FIRM RECEIVING IT IS DEEMED, BY RECEIVING IT, TO AGREE THAT IT, AND/OR ANY PART OF IT, SHALL NOT BE DISCLOSED TO ANY PERSON, CORPORATION OR OTHER ENTITY, DUPLICATED, AND/OR USED, EXCEPT AS EXPRESSLY APPROVED IN WRITING IN ADVANCE BY OWNER. THIS DOCUMENT SHALL BE RETURNED TO OWNER UPON REQUEST. IT MAY BE SUBJECT TO CERTAIN RESTRICTIONS UNDER APPLICABLE EXPORT CONTROL LAWS AND REGULATIONS.</small>			THIRD ANGLE PROJECTION	DATE 10/19/2015	REFERENCE	MATERIAL
			mm SHOWN IN [BRACKETS]	DATE 10/19/2015	REFERENCE	PROCESS/FINISH BLACK
				DATE 10/19/2015	REFERENCE	SIZE C
				DATE 10/19/2015	REFERENCE	DRAWING NUMBER 71635122
				DATE 10/19/2015	REFERENCE	SHEET 1 OF 2

ORACLE PART REV. 027

- NOTES:
 1. STAKE STATOR TO SLEEVE PER 88830264.
 2. MAXIMUM TORQUE REQUIRED TO TURN MOTOR SHAFT IS 3/8 INCH-OUNCE.
 3. MAKE-UP WASHERS ARE TO BE ADDED OR DELETED TO ACHIEVE REQUIRED ENDPLAY.
 4. LEAD RIP MUST NOT EXTEND OUTSIDE OF SLEEVE.

FRONT END

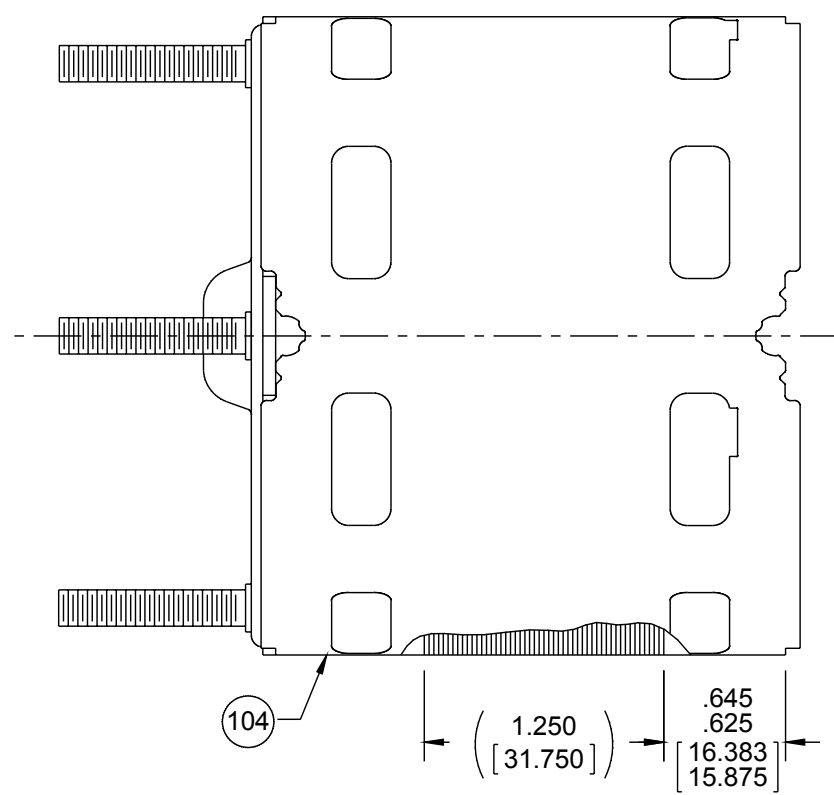

BACK END

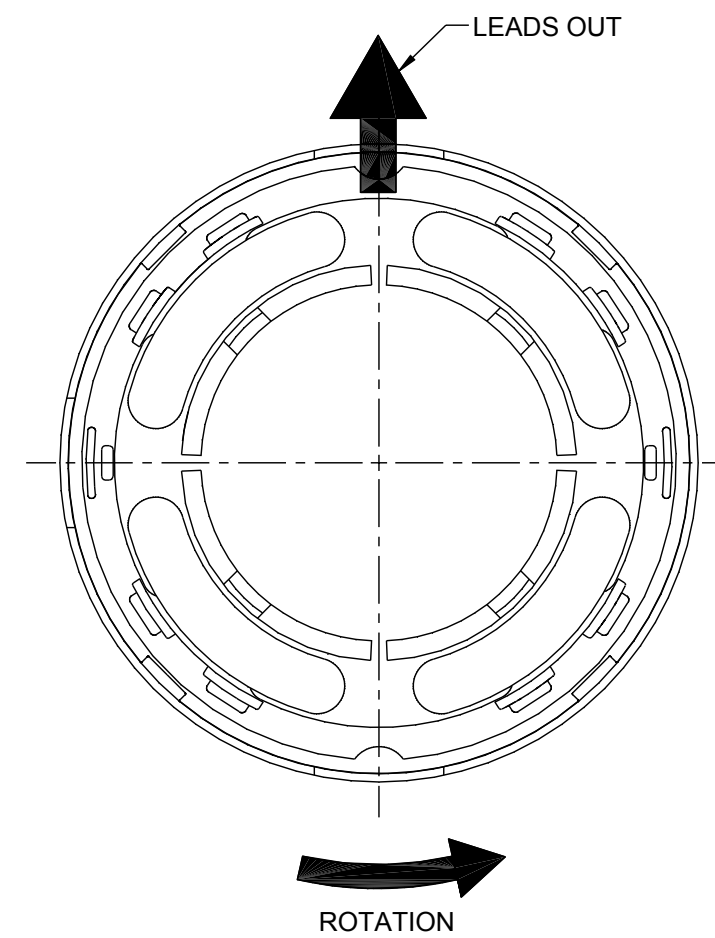

PACKING SPECIFICATIONS

1. PACK 1 PER CARTON, 45 PER LAYER, 405 MAX. PER PALLET, PER 88834200.
2. PLACE FOAM RING ON CLIP END, FILLER TUBE OVER SHAFT EXTENSION, PLACE MOTOR IN CARTON, CLOSE FLAPS AND TAPE. PLACE CARTON ON SHAFT END OF PALLET.
3. PLACE (1) FLAT PAD ON PALLET, (1) BETWEEN EACH LAYER AND (1) ON TOP. PLACE CARTONS ON PALLET WITH LABELED END OUT AND VISIBLE FOR STORAGE. PLACE ALL INSPECTION STICKERS AND WRITING ON TOP FLAT PAD.
4. CARTON LABELS MUST ALL FACE ONE DIRECTION TOWARD THE OPEN END OF THE PALLET. SEE 88834408.

DRAWING REVISION AH		REVISION BY SDM	DATE 10/19/2015	TOLERANCES UNLESS OTHERWISE SPECIFIED:		DRAWN BY SDM		REGAL™ Regal Beloit America, Inc.	
ECO ECO-0084443	APPROVED BY KSA	DATE 10/19/2015		DEC.	INCH	mm	ANGLE	DATE 10/19/2015	DESCRIPTION MOTOR ASSY
ECO DESCRIPTION ADD VENT, CHANGE N/P FORMAT TO 00464071				.X	±0.1	[±2.5]	±1°	APPROVED BY KSA	
<small>COPYRIGHT REGAL BELOIT AMERICA, INC. ALL RIGHTS RESERVED. PROPRIETARY AND CONFIDENTIAL INFORMATION - THIS DOCUMENT IS THE PROPERTY OF REGAL BELOIT AMERICA, INC. ("OWNER") AND CONTAINS OWNER'S PROPRIETARY INFORMATION. ANY PERSON, CORPORATION OR OTHER FIRM RECEIVING IT IS DEEMED, BY RECEIVING IT, TO AGREE THAT IT, AND/OR ANY PART OF IT, SHALL NOT BE DISCLOSED TO ANY PERSON, CORPORATION OR OTHER ENTITY, DUPLICATED, AND/OR USED, EXCEPT AS EXPRESSLY APPROVED IN WRITING IN ADVANCE BY OWNER. THIS DOCUMENT SHALL BE RETURNED TO OWNER UPON REQUEST. IT MAY BE SUBJECT TO CERTAIN RESTRICTIONS UNDER APPLICABLE EXPORT CONTROL LAWS AND REGULATIONS.</small>				.XX	±0.01	[±0.25]		DATE 10/19/2015	
				.XXX	+0.005	[±0.127]		REFERENCE	MATERIAL
				.XXXX	+0.0005	[±0.0127]		THIRD ANGLE PROJECTION	SIZE C
				REMOVE BURRS & BREAK SHARP EDGES: .003/.015 [.076/.381] X 45°		MACHINED SURFACES: 125/3.2		DRAWING NUMBER 71635122	
				CORNER FILLETS: R.02 [.51]		mm SHOWN IN [BRACKETS]		SHEET 2 OF 2	