

09	REVISED TO POWDER PAINT	SD 6-13-05	10	REVISE NAMEPLATE LABEL TO NEW LAYOUT	MLM 12/27/07	11	REMOVED BARCODE AND ADDED CSA NUMBER TO NAMEPLATE	BGP 07/26/10	STANDARD TOLERANCES: ANGULAR +/- 1 DEGREE 2 PLACE DECIMAL +/- .01 3 PLACE DECIMAL +/- .005
----	-------------------------	------------	----	--------------------------------------	--------------	----	---------------------------------------------------	--------------	-----------------------------------------------------------------------------------------------

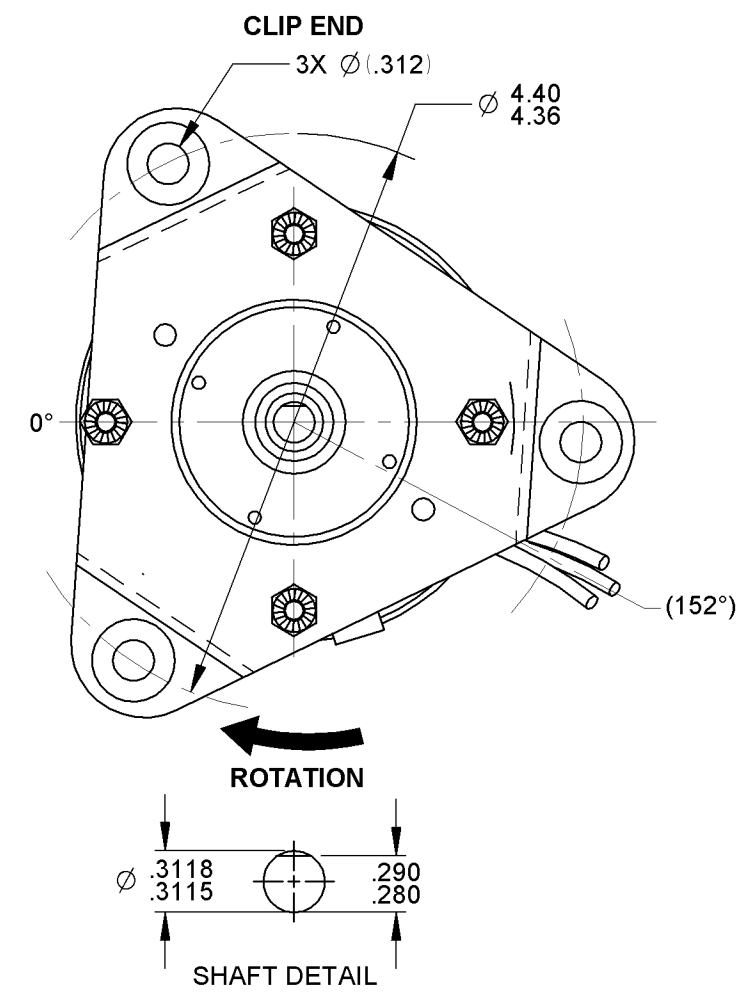
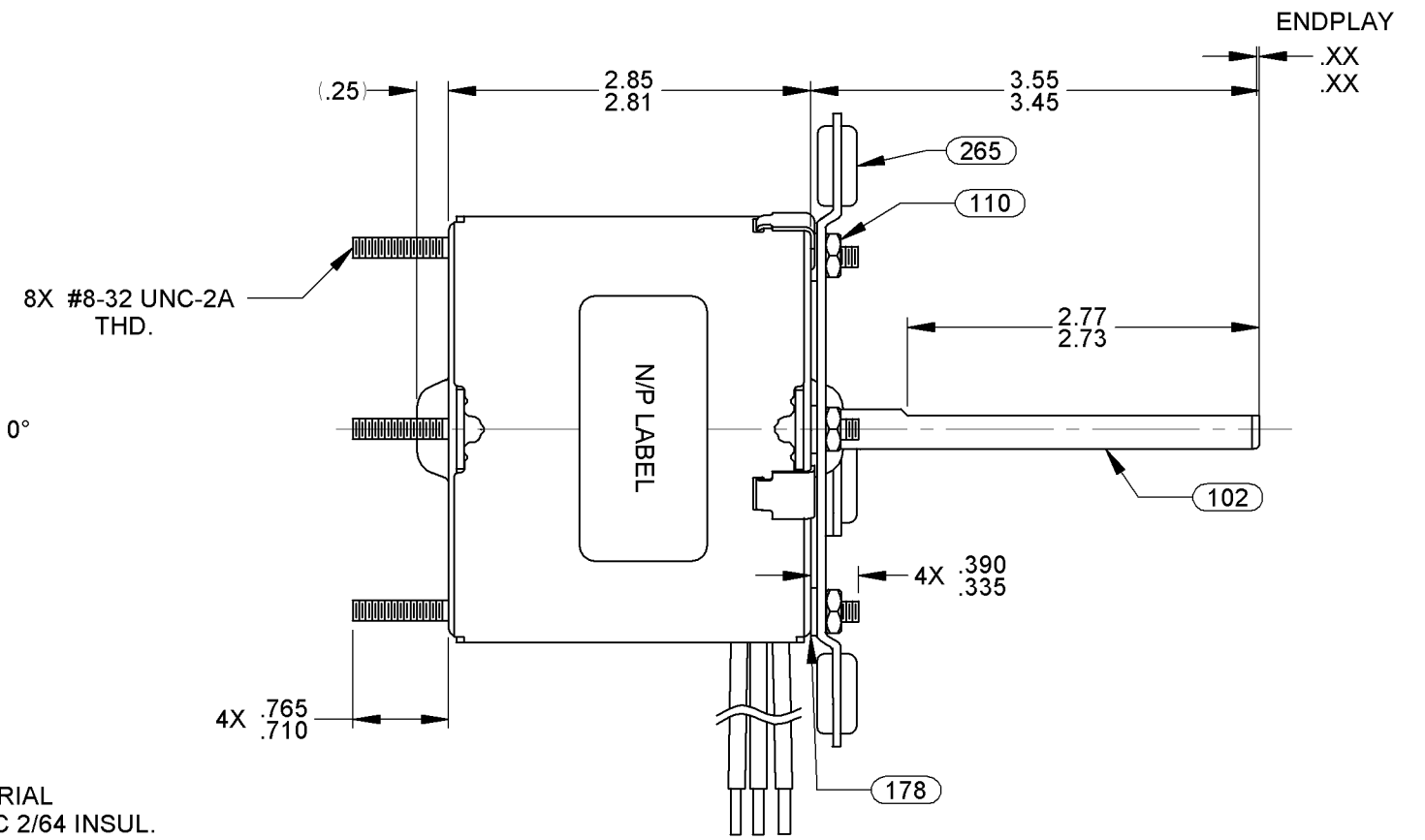
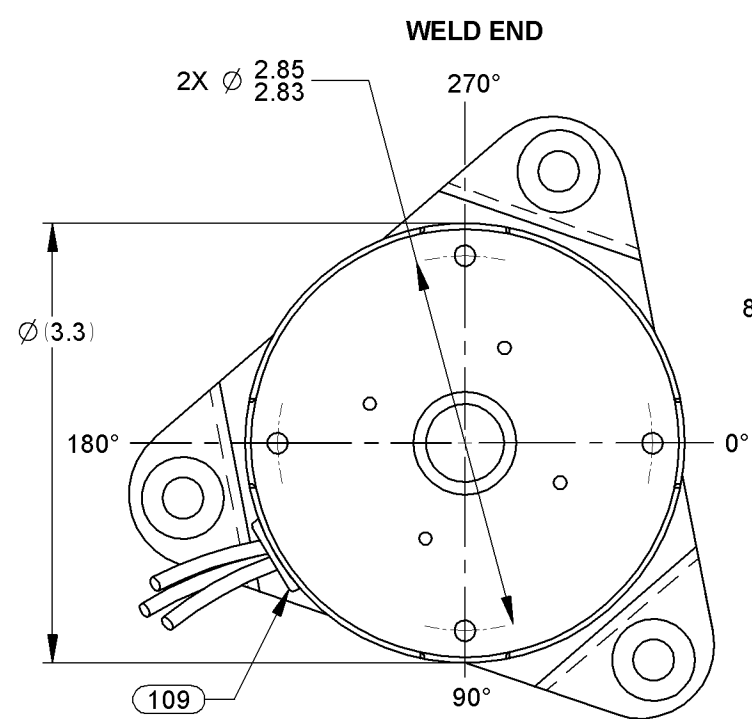

LEAD MATERIAL
18 GA. 125°C 2/64 INSUL.
X-LINKED POLY, (2)BLACK,
25.00/23.00 IN. LONG
.56/.44 IN. STRIP

GROUND LEAD
18 GA. 125°C 2/64 INSUL.
X-LINKED POLY, GRN/YEL,
25.00/23.00 IN. LONG
.56/.44 IN. STRIP

NOTES:

1. PACK MOTORS 175 MAX. PER PALLET.
2. NO PACKAGING TAPE OVER CARTON LABEL.

0046-4072

0046-4282

	Fasco Industries, Inc. Motor Division				SAFETY WARNING This Motor Must Be Grounded in Accordance With Local Or National Electrical Codes To Prevent Possible Injury Due To Electrical Shock
	Assembled in Mexico				
No. 71637874	TYPE U63B1	T.P. TEAO			
240 V	60/50 Hz	Class B			
0.6 A	1550/1300 RPM	1/30 HP			
Model D1118		Max Amb:40°C			
Sealed Ball Brg					
LR6319					

61299553

FRONT SHAFT POSITION	* TYPICAL PERFORMANCE AT 240 VOLTS 50/60 Hz.												CUSTOMER: FASCO DIST.	FASCO MOTORS GROUP AC MOTOR/BLOWER DIVISION CONFIDENTIAL: DO NOT DUPLICATE OR DISCLOSE TO THIRD PARTIES WITHOUT WRITTEN PERMISSION OF FASCO MOTORS GROUP, AC MOTOR/BLOWER DIVISION.									
HORIZONTAL	MOTOR SPEED	IDLE			LOADED			LOCKED			BREAK	PART NUMBER: D1118	APPLICATION:										
UP DOWN	50 Hz	R.P.M.	AMP.	WATT	IN.OZ.	R.P.M.	AMP.	WATT	IN.OZ.	AMP.	WATT	IN.OZ.	MOTOR WEIGHT: 3.56 POUNDS	MOTOR TYPE	DRAWING NUMBER								
CUSTOMER APPROVAL:	60 Hz	1437	.56	62	27.8	1300	.61	90	12.1	.89	135	31.0	ENVIRONMENT: DRY	SHADED POLE	7163 7874								
SIGNED:													FINISH COLOR: BLACK										
DATE:													DRAWN BY: TAMMY JONES	B	LA	FR	A	S	C	E	B	A	REV.
													DATE DRAWN: DECEMBER 10, 2001	00	63	33	T	05	JR	5	0	0	11