

- NOTES:
- 270 MAX. MOTORS PER PALLET.
  - NO LEAD GROMMET REQUIRED.
  - MOTOR HAS #416 STAINLESS STEEL SHAFT.
  - NO PACKING TAPE OVER CARTON LABEL.

00464296

Fasco Ind. Inc. Class B  
Assembled in Mexico

No. 71730292 TYPE U73B1 AO  
115V 60Hz 1.0 A 1/40 HP  
1550 RPM Thermally Protected  
Model D105

6129953

61305815

SAFETY WARNING  
This motor must be grounded in accordance with local or national electrical codes to prevent possible injury due to electrical shock.

AVERTISSEMENT DE SECURITE  
Ce moteur doit être fondée sur conformément à la réglementation locale ou nationale électrique codes pour prévenir d'éventuelles blessures en raison de choc électrique.

CUSTOMER:	FDC	APPLICATION:									
CUSTOMER PN:	D105	MOTOR WEIGHT:	2.00 POUNDS								
		ENVIRONMENT:	DRY								
		MOTOR TYPE									
		SHADED POLE									
		B	LA								
		FR	A								
		S	C								
		E	B								
		A	A								
		00	73								
		30	V								
		01	ER								
		5	1								
		0	0								
TYPICAL PERFORMANCE AT 115 VOLTS 60 HZ											
	IDLE			LOADED			LOCKED			BREAK	
MOTOR SPEED	RPM	AMP	WATT	IN OZ	RPM	AMP	WATT	IN OZ	AMP	WATT	IN OZ
	1747	.88	54	15.9	1550	.94	74	7.0	1.26	104	19.2

DRAWING REVISION	AA	REVISION BY	FDP	DATE	8/23/2017	TOLERANCES UNLESS OTHERWISE SPECIFIED:	DRAWN BY	FDP
ECO	0129348	APPROVED BY	PLA	DATE	8/23/2017	DEC.		
CHANGED WARNING LABEL TO AGENCY STANDARDS						INCH		
COPYRIGHT REGAL BELTO AMERICA, INC. ALL RIGHTS RESERVED.						mm		
PROPRIETARY AND CONFIDENTIAL INFORMATION. THIS DOCUMENT IS THE PROPERTY OF REGAL BELTO AMERICA, INC. FORMERLY AND CONTAINS OWNERS PROPRIETARY INFORMATION. ANY PERSON, CORPORATION OR OTHER FIRM RECEIVING IT IS DEEMED BY RECEIVING IT, TO AGREE THAT IT, AND/OR ANY PART OF IT, SHALL NOT BE DISCLOSED TO ANY PERSON, CORPORATION OR OTHER ENTITY, DUPLICATED, AND/OR USED, EXCEPT AS EXPRESSLY APPROVED IN WRITING IN ADVANCE BY OWNER. THIS DOCUMENT SHALL BE RETURNED TO OWNER UPON REQUEST. IT MAY BE SUBJECT TO CERTAIN RESTRICTIONS UNDER APPLICABLE EXPORT CONTROL LAWS AND REGULATIONS.						ANGLE		
						°		
						REMOVE BURRS & BREAK SHARP EDGES: .0031 [0.078] X 45° CORNER FILLETS: R.02 [51]	DATE	8/23/2017
						MACHINED SURFACES: .125 / 3.2 INCH / mm SHOWN IN [BRACKETS]	APPROVED BY	PLA
						REFERENCE	8/23/2017	DESCRIPTION
						THIRD ANGLE PROJECTION		OUTLINE MOTOR ASSY
						SIZE	C	MATERIAL
						DRAWING NUMBER	71730292	PROCESS/FINISH
								BLACK
								SHEET
								1 OF 2

NOTES:

1. STAKE STATOR TO SLEEVE PER 88830264.
2. MAXIMUM TORQUE REQUIRED TO TURN MOTOR SHAFT IS 3/8 INCH-OUNCE.
3. MAKE-UP WASHERS ARE TO BE ADDED OR DELETED TO ACHIEVE REQUIRED ENDPLOY.

FRONT END

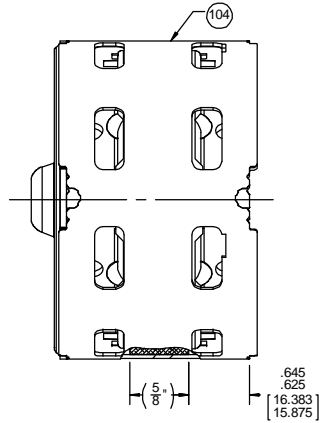

BACK END

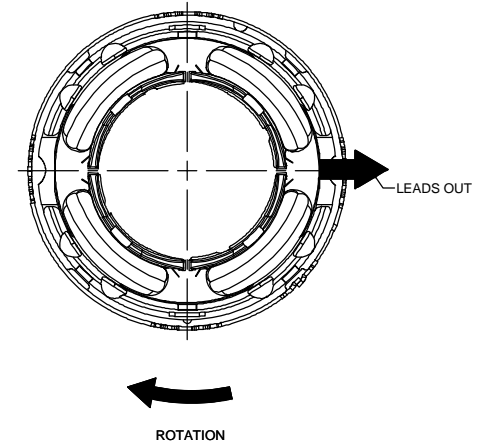

PACKING SPECIFICATIONS

1. PACK PER 88834200. 1 PER CARTON, 45 PER LAYER, 270 MAX, PER PALLET.
2. PLACE FOAM RING ON OPPOSITE SHAFT END AND FILLER TUBE OVER SHAFT. PLACE MOTOR IN CARTON SHAFT UP. CLOSE FLAPS AND TAPE.
3. PLACE CARTON LABEL ON SHAFT EXTENSION END OF CARTON. PLACE (1) FLAT PAD ON PALLET. LAY CARTONS ON SIDE ON PALLET WITH LABELED END OUT AND VISIBLE FOR STORAGE.
4. PLACE (1) FLAT PAD BETWEEN EACH LAYER AND (1) ON TOP.
5. PLACE ALL INSPECTED STICKERS AND WRITING ON FLAT PAD.
6. CARTON LABELS MUST ALL FACE ONE DIRECTION TOWARD THE OPEN END OF THE PALLET. SEE 88834408.

DRAWING REVISION AA	REVISION BY FDP	DATE 8/23/2017	TOLERANCES UNLESS OTHERWISE SPECIFIED: DEC. INCH mm ANGLE	DRAWN BY FDP	Regal Beloit America, Inc.
ECO-0129348	APPROVED BY PLA	DATE 8/23/2017	.X ±0.1 [±2.5] ±1° .XX ±0.01 [±0.25] .XXX ±0.005 [±0.127] .XXXX ±0.0005 [±0.0127]	DATE 8/23/2017	
ECO DESCRIPTION CHANGED WARNING LABEL TO AGENCY STANDARDS			REMOVE BURRS & BREAK SHARP EDGES. .0031 .015 [0.078/.381] X 45° CORNER FILLETS: R.02 [.51]	APPROVED BY PLA	DESCRIPTION OUTLINE MOTOR ASSY
<small>PROPRIETARY AND CONFIDENTIAL INFORMATION. THIS DOCUMENT IS THE PROPERTY OF REGAL BELOIT AMERICA, INC. FORMERLY AND CONTAINS OWNERS PROPRIETARY INFORMATION. ANY PERSON, CORPORATION OR OTHER FIRM RECEIVING IT IS DEEMED BY RECEIVING IT, TO AGREE THAT IT, AND/OR ANY PART OF IT, SHALL NOT BE DISCLOSED TO ANY PERSON, CORPORATION OR OTHER ENTITY, DUPLICATED, AND/OR USED, EXCEPT AS EXPRESSLY APPROVED IN WRITING IN ADVANCE BY OWNER. THIS DOCUMENT SHALL BE RETURNED TO OWNER UPON REQUEST. IT MAY BE SUBJECT TO CERTAIN RESTRICTIONS UNDER APPLICABLE EXPORT CONTROL LAWS AND REGULATIONS.</small>			MACHINED SURFACES: .125/ 3.2 INCH/ mm SHOWN IN [BRACKETS]	DATE 8/23/2017	MATERIAL
			THIRD ANGLE PROJECTION	REFERENCE	PROCESS/FINISH BLACK
			SIZE C	DRAWING NUMBER 71730292	SHEET 2 OF 2