

THERMALLY PROTECTED
CLASS "B" INSULATION
416 SS SHAFT

APPLICATION:	DISTRIBUTION	B	LA	FR	A	S	C	E	B	A
CUSTOMER:	FDC	GS	21	47	V	04	AX	5	3	0
CUSTOMER PN:	A223	FINISH: BLOWER-NATURAL, MOTOR-FLAT BLACK								

LEAD MATERIAL
18 GA. 125° 4/64 INSUL.
EPDM (1) BLACK, (1) PURPLE
34.00/32.00 [863.60/812.80]
W/FSPADE TERM.
AMP 2-520263-2

NOTES:

1. DIMENSION WITH END PLAY PUSHED TOWARD MOTOR FROM INSIDE OF HOUSING.
2. INSPECTION TEST FIXTURING IS REQUIRED.
3. STATIC TAP READING IS TO BE 1.22 MINIMUM CORRECTED TO STANDARD AIR (0.075 LB/FT³) WITH A 1 5/16 INLET RESTRICTOR.
4. PACK 1 PER CONTAINER, 16 CONTAINERS PER LAYER, 5 LAYERS PER PALLET, 80 MAX. PER PALLET, PACKING ASSY. 87854335, PER 88834200 AND 88834408.
5. CARTON LABELS MUST ALL FACE ONE DIRECTION TOWARD THE OPEN END OF THE PALLET. SEE 88834408.
6. NO PACKAGING TAPE OVER CARTON LABEL.

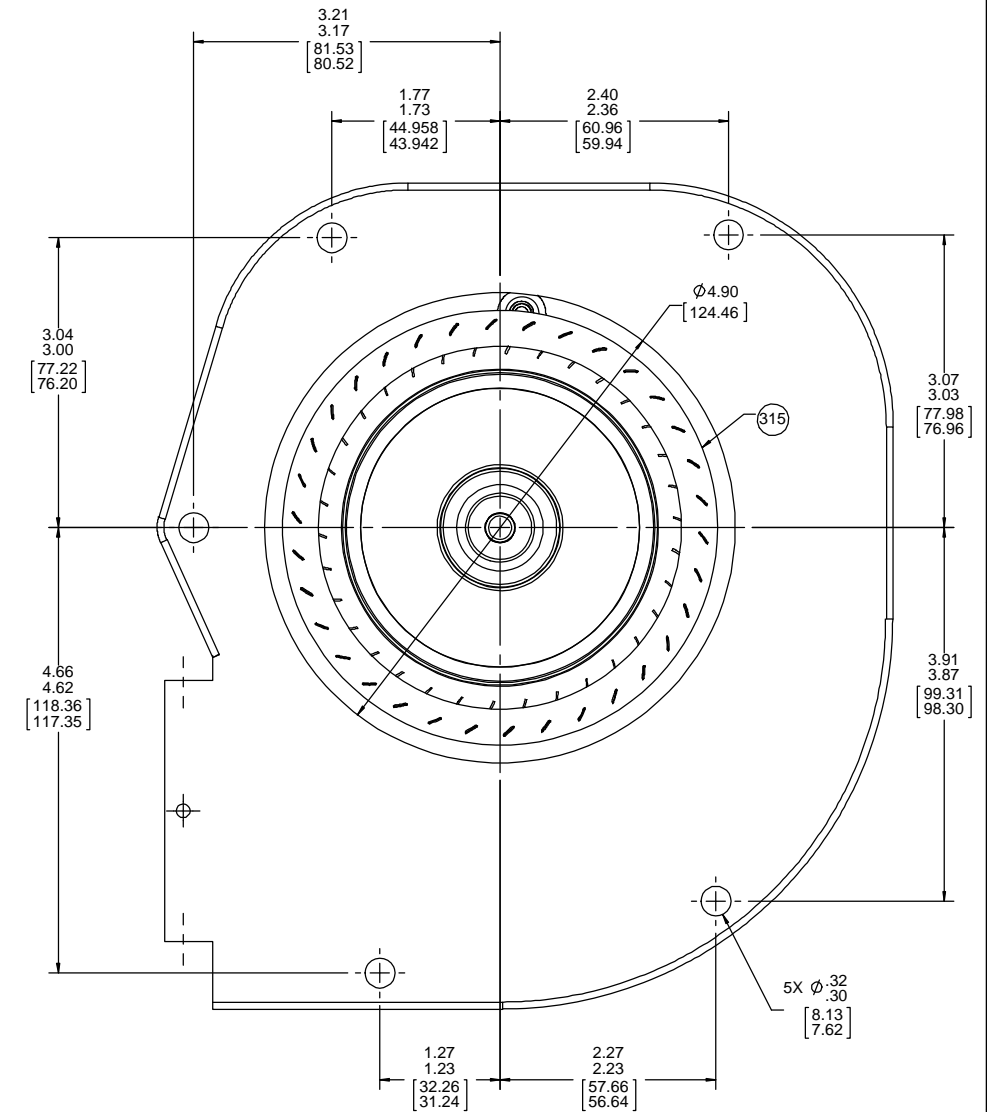
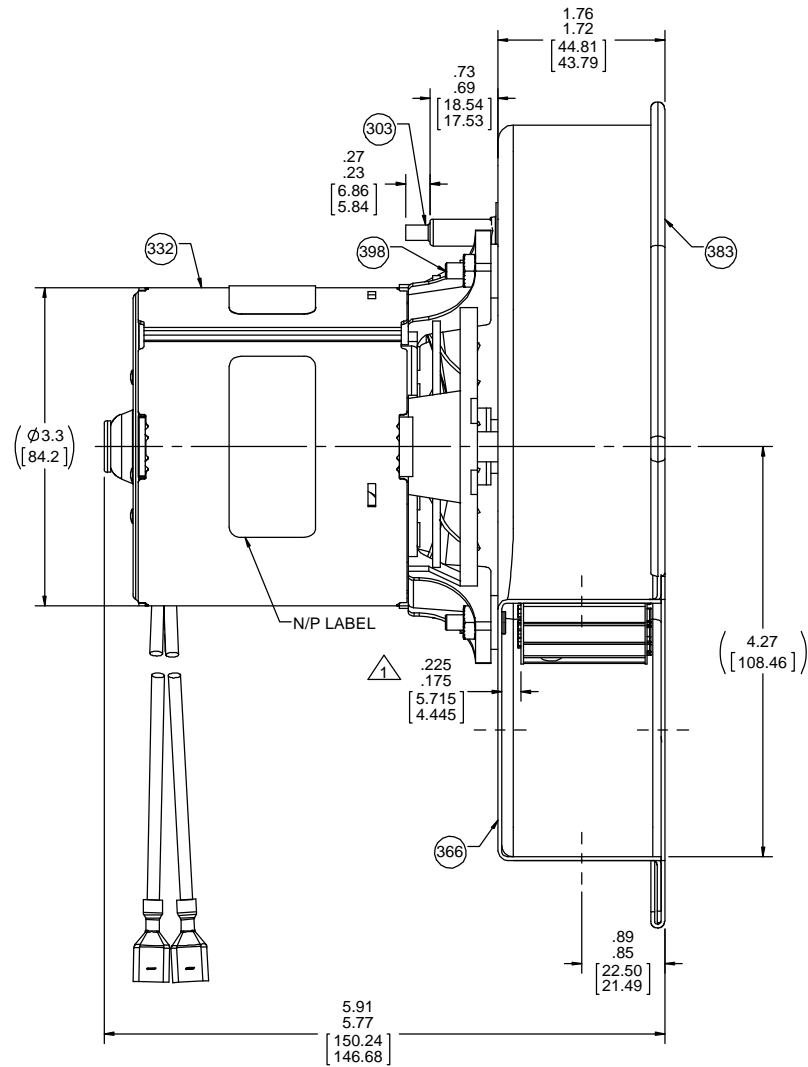
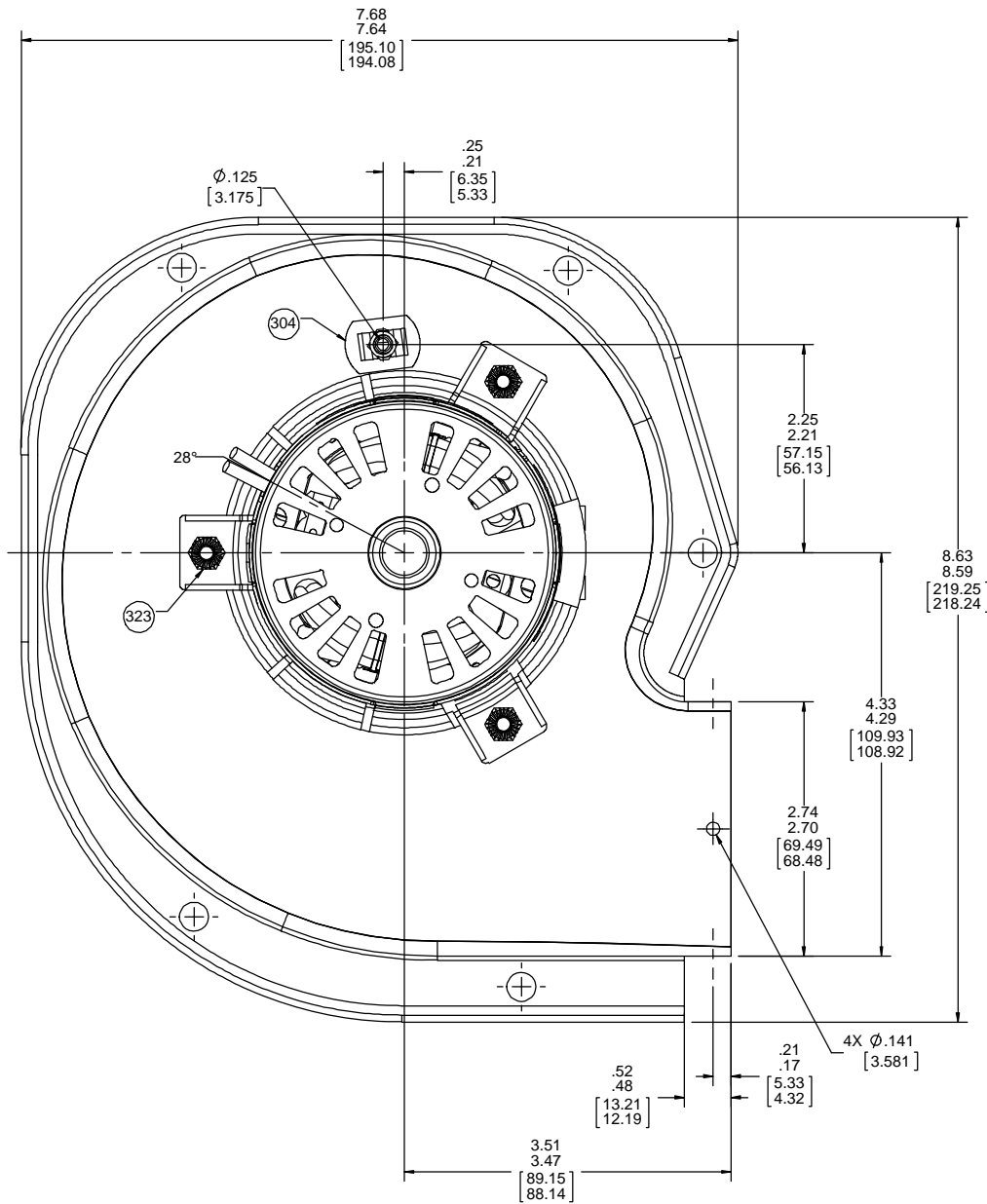

AVERAGE PERFORMANCE TEST DATA WITH A 1 5/16 INLET RESTRICTOR			
AT 230 VOLTS 60 Hz			
	RPM	WATTS	AMPS
	3375	81.3	.60
BLOWER WEIGHT	4 1/2 LBS.		ENDPLAY .030/.010 [.762/.254]

DRAWING REVISION AA	REVISION BY MLS	DATE 9/18/2018	TOLERANCES UNLESS OTHERWISE SPECIFIED: DEC. INCH mm ANGLE ±1° .X ±0.1 [2.5] .XX ±0.01 [0.25] .XXX ±0.005 [0.127] XXXX ±0.0005 [0.0127]	DRAWN BY MLS	DATE 9/18/2018	DESCRIPTION OUTLINE BLOWER ASSY
ECO-0152862	APPROVED BY FDP	DATE 9/18/2018	REMOVE BURRS & BREAK SHARP EDGES: .003/.015 [0.076/.381] X 45° CORNER FILLETS: R.02 [51] MACHINED SURFACES: 125/ INCR/ 32/ mm SHOWN IN [BRACKETS]	APPROVED BY FDP	DATE 9/18/2018	MATERIAL PROCESS/FINISH
<small>PROPRIETARY AND CONFIDENTIAL INFORMATION - THIS DOCUMENT IS THE PROPERTY OF REGAL BELLOIT AMERICA, INC. CONCEPT AND CONTENT ARE OWNERS PROPRIETARY INFORMATION. ANY PERSON, CORPORATION OR OTHER FIRM RECEIVING IT IS DEEMED, BY RECEIVING IT, TO AGREE THAT IT, AND/OR ANY PART OF IT, SHALL NOT BE DISCLOSED TO ANY PERSON, CORPORATION OR OTHER ENTITY, DUPLICATED, AND/OR USED, EXCEPT AS EXPRESSLY APPROVED IN WRITING IN ADVANCE BY OWNER. THIS DOCUMENT SHALL BE RETURNED TO OWNER UPON REQUEST. IT MAY BE SUBJECT TO CERTAIN RESTRICTIONS UNDER APPLICABLE EXPORT CONTROL LAWS AND REGULATIONS.</small>			THIRD ANGLE PROJECTION	SIZE D	DRAWING NUMBER 702111698	SHEET 1 OF 1

Regal Beloit America, Inc.

OUTLINE
BLOWER ASSY

702111698