

THERMALLY PROTECTED
CLASS "B" INSULATION
SEALED BALL BEARING
416 SS SHAFT

APPLICATION:		B	LA	FR	A	S	C	E	B	A
CUSTOMER:	FASCO DIST	PS	21	47	F	06	FJ	6	0	0
CUSTOMER PN:	A213	FINISH: BLOWER-NATURAL, MOTOR-FLAT BLACK								

NOTES:

- ASSEMBLE WATER SLINGER AFTER MOTOR HAS BEEN ASSEMBLED.
- ALL UNITS TO BE 100% TESTED ON AUTOMATIC TEST FIXTURES PER TEST LIMITS ESTABLISHED IN THE TESTER DATABASE.
- TEST FIXTURE IS REQUIRED.
- ALL UNITS TO BE CHECKED 100% OFR VACUUM, TEST 1 OF 20 FOR LEAKAGE.
- STATIC TAP TO READ -1.85 MINIMUM ON HIGH SPEED CORRECTED TO STANDARD AIR (0.075 LB/FT³) WITH A 1.25 [31.75] INLET RESTRICTOR.
- PACK 1 PER CONTAINER, 12 CONTAINERS PER LAYER, 3 LAYERS PER PALLET, 36 MAX. PER PALLET, PACKING ASSY. 87854866, PER 88834200 AND 88834408.
- CARTON LABELS MUST ALL FACE ONE DIRECTION TOWARD THE OPEN END OF THE PALLET. SEE 88834408.
- NO PACKAGING TAPE OVER CARTON LABEL.

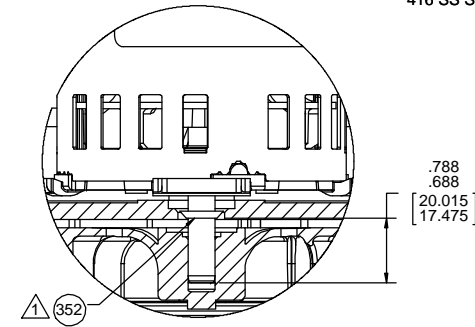

SECTION A-A

LEAD MATERIAL
18 GA. 125°C 4/64 INSUL.
EPDM
8.00/6.00 [203.20/152.40]
(1) WHITE
W/PIN TERM.
AMP 350538-1
(1) BLACK AND (1) RED
W/SOCKET TERMS.
AMP 350537-1

GROUND LEAD MATERIAL
18 GA. 125°C 2/64 INSUL.
X-LINKED POLY.
GRN/YEL
19.00/17.00 [482.60/431.80]
W/RING TERM.
AMP 40660

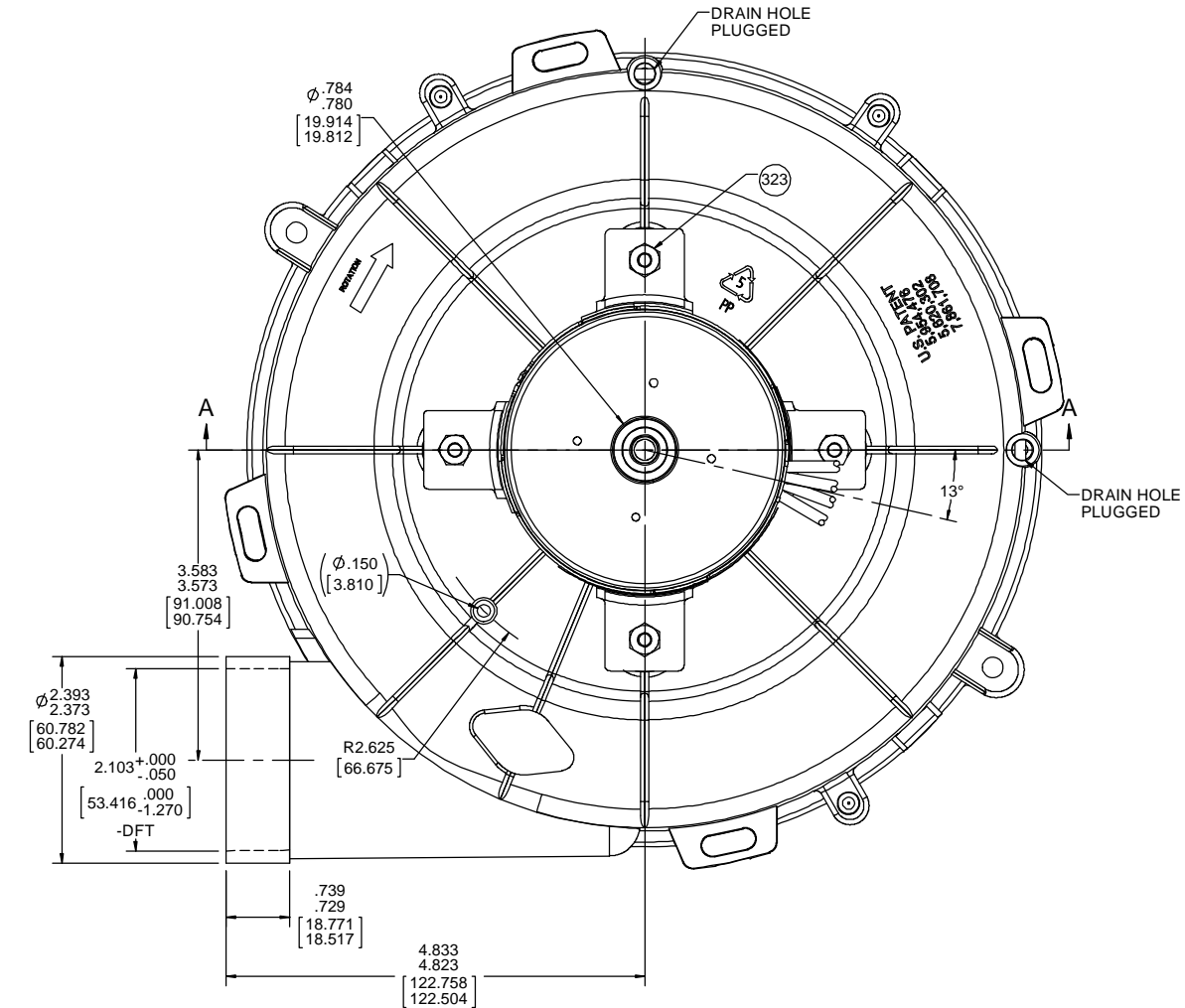
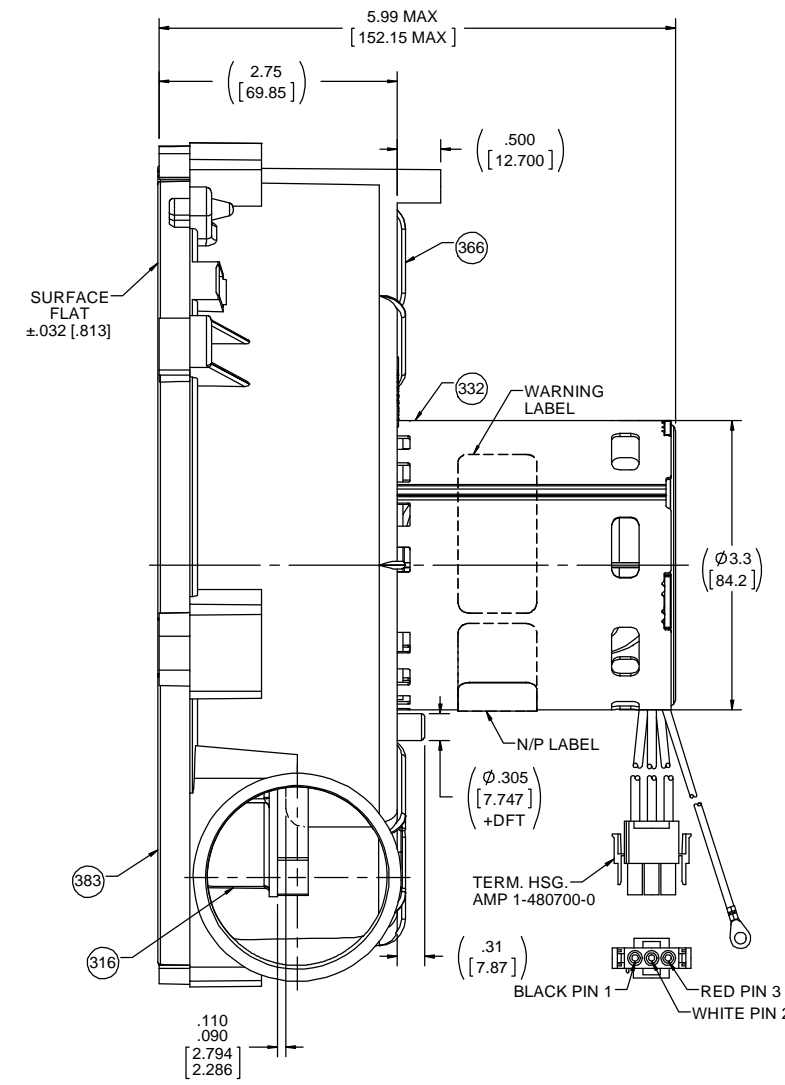
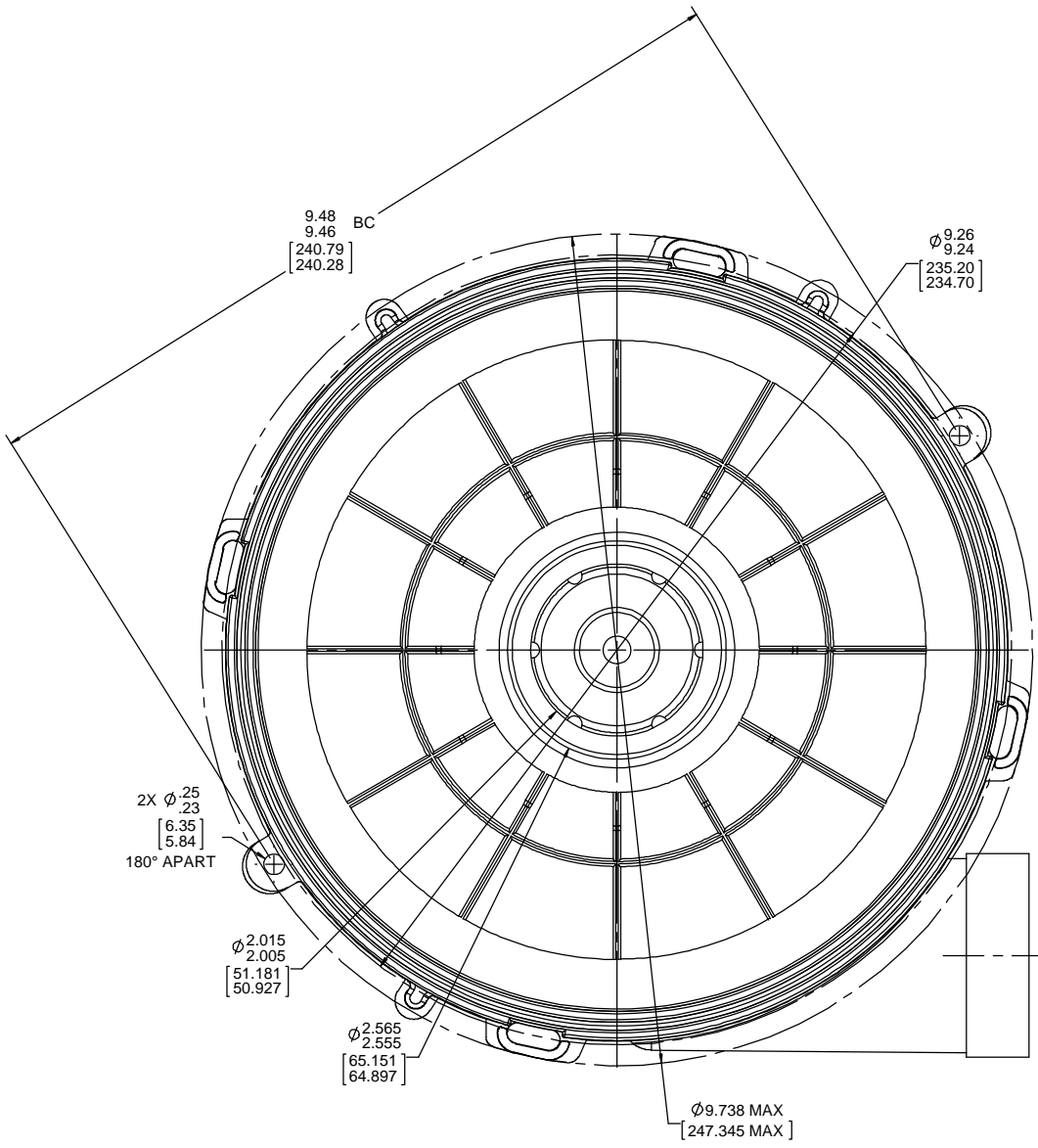

Connection Diagram
Whit — Common
Blk — High
Red — Low

AVERAGE PERFORMANCE TEST DATA WITH A 1.25 INLET RESTRICTOR			
AT 115 VOLTS 60 Hz			
	RPM	WATTS	AMPS
HIGH	3168	141	2.04
LOW	2777	75	1.03
BLOWER WEIGHT	5.25 LBS.		ENDPLAY .XX/XX

DRAWING REVISION AA	REVISION BY MLS	DATE 12/12/2018	TOLERANCES UNLESS OTHERWISE SPECIFIED: DEC. INCH mm ANGLE .X ±0.1 [2.5] ±1° .XX ±0.01 [0.25] .XXX ±0.005 [0.127] XXXX ±0.0005 [0.0127]	DRAWN BY MLS	DATE 12/12/2018	DESCRIPTION OUTLINE BLOWER ASSY
ECO-0158237	APPROVED BY FDP	DATE 12/12/2018	REMOVE BURRS & BREAK SHARP EDGES: .003/.015 [0.076/.381] X 45° CORNER FILLETS: R.02 [51] MACHINED SURFACES: 125/ INCR/ 32/ mm SHOWN IN [BRACKETS]	APPROVED BY FDP	DATE 12/12/2018	MATERIAL PROCESS/FINISH
<small>REGAL BELLOI AMERICA, INC. CONFIDENTIAL AND PROPRIETARY INFORMATION. THIS DOCUMENT IS THE PROPERTY OF REGAL BELLOI AMERICA, INC. CONSENT AND CONTAINING OWNERS PROPRIETARY INFORMATION. ANY PERSON, CORPORATION OR OTHER FIRM RECEIVING IT IS DEEMED, BY RECEIVING IT, TO AGREE THAT IT AND/OR ANY PART OF IT, SHALL NOT BE DISCLOSED TO ANY PERSON, CORPORATION OR OTHER ENTITY, DUPLICATED, AND/OR USED, EXCEPT AS EXPRESSLY APPROVED IN WRITING IN ADVANCE BY OWNER. THIS DOCUMENT SHALL BE RETURNED TO OWNER UPON REQUEST. IT MAY BE SUBJECT TO CERTAIN RESTRICTIONS UNDER APPLICABLE EXPORT CONTROL LAWS AND REGULATIONS.</small>			THIRD ANGLE PROJECTION	SIZE D	DRAWING NUMBER 702112097	SHEET 1 OF 1

Regal Beloit America, Inc.

OUTLINE
BLOWER ASSY

702112097