

THERMALLY PROTECTED CLASS "B" INSULATION SEALED BALL BEARING 416 SS SHAFT

APPLICATION:	GAS FURNACE	B	LA	FR	A	S	C	E	B	A
CUSTOMER:	FASCO DIST.	PS	21	47	F	06	ET	5	0	0
CUSTOMER PN:	A211									

- NOTES:
- ASSEMBLE PC 352 SEAL BEFORE MOTOR HAS BEEN ASSEMBLED.
 - ALL UNITS TO BE 100% TESTED ON AUTOMATIC TEST FIXTURES PER TEST LIMITS ESTABLISHED IN THE TESTER DATABASE.
 - INSPECTION TEST FIXTURE REQUIRED.
 - PACK 1 PER CONTAINER, 12 CONTAINERS PER LAYER, 3 LAYERS PER PALLET, 36 MAX. AMT PER PALLET, PACKING ASSY. 87854866, PER 88834200 AND 88834408. PLACE GASKET PC 319 IN CARTON WITH BLOWER.
 - CARTON LABELS MUST ALL FACE ONE DIRECTION TOWARD THE OPEN END OF THE PALLET PER 8884408.
 - NO PACKAGING TAPE OVER CARTON LABEL.
 - BLOWER - BLACK, MOTOR - GRAY.

LEAD MATERIAL
18 GA. 125°C 2/64 INSUL.
X-LINKED POLY. (1) BLACK, (1) WHITE
8.00/6.00 [203.20/152.40]
SOCKET TERMS.
AMP 350536-1

GROUND LEAD MATERIAL
GRN/YEL
33.00/31.00 [838.20/152.40]
FSPADE TERM.
AMP 41274

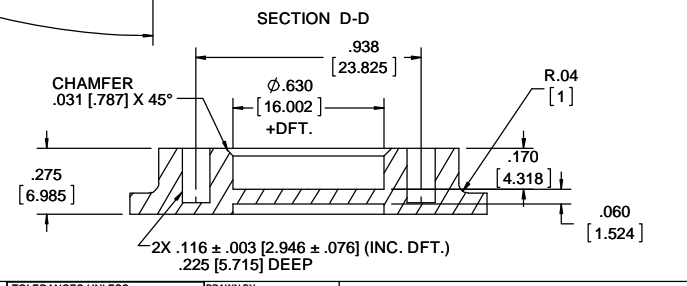
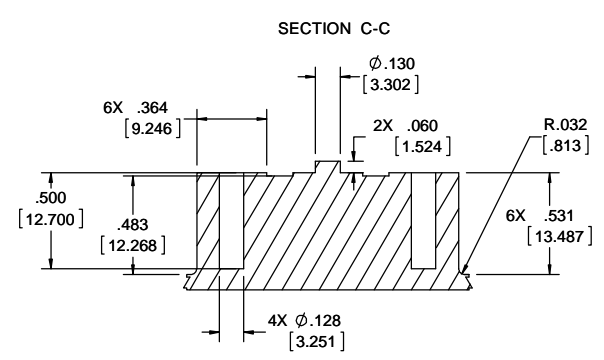
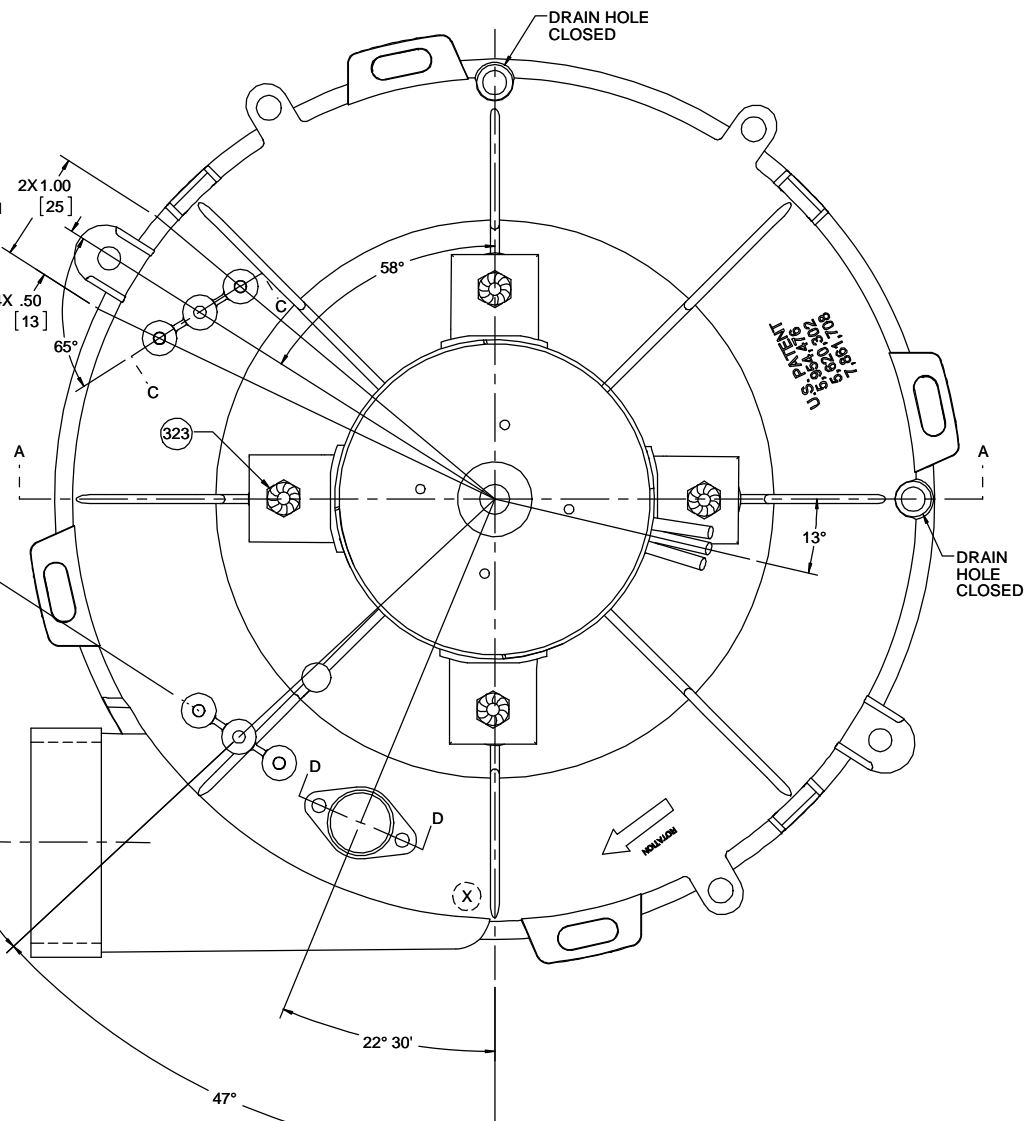
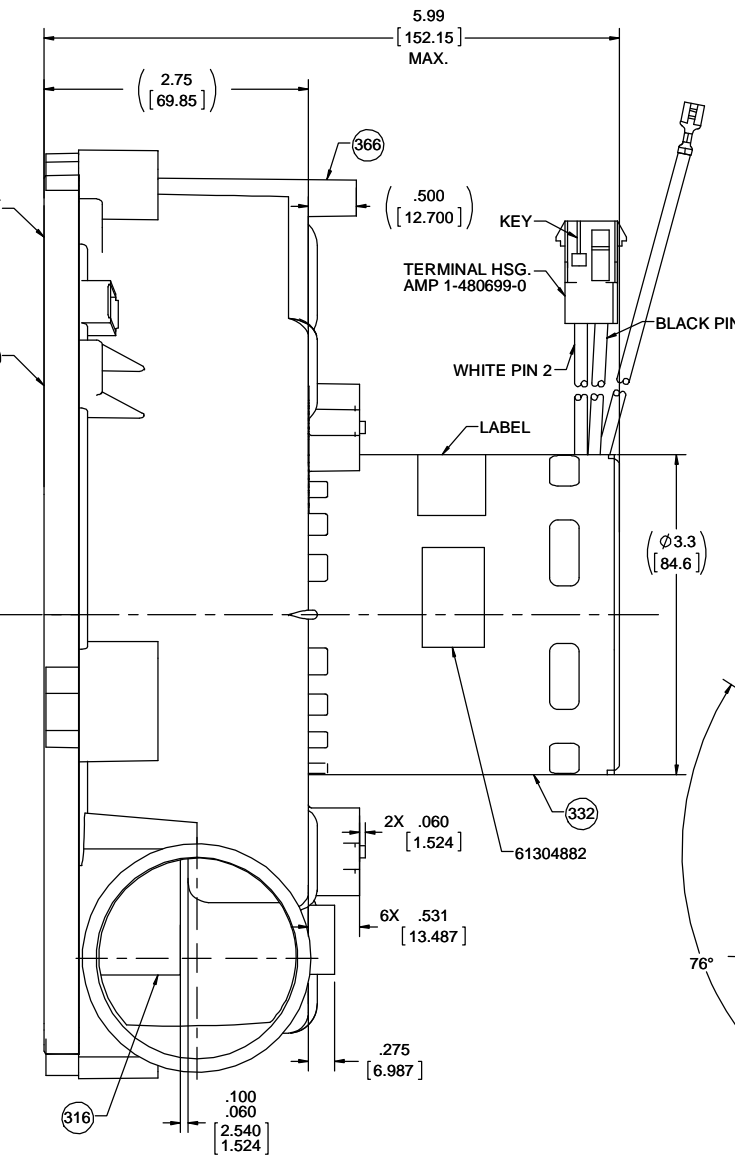
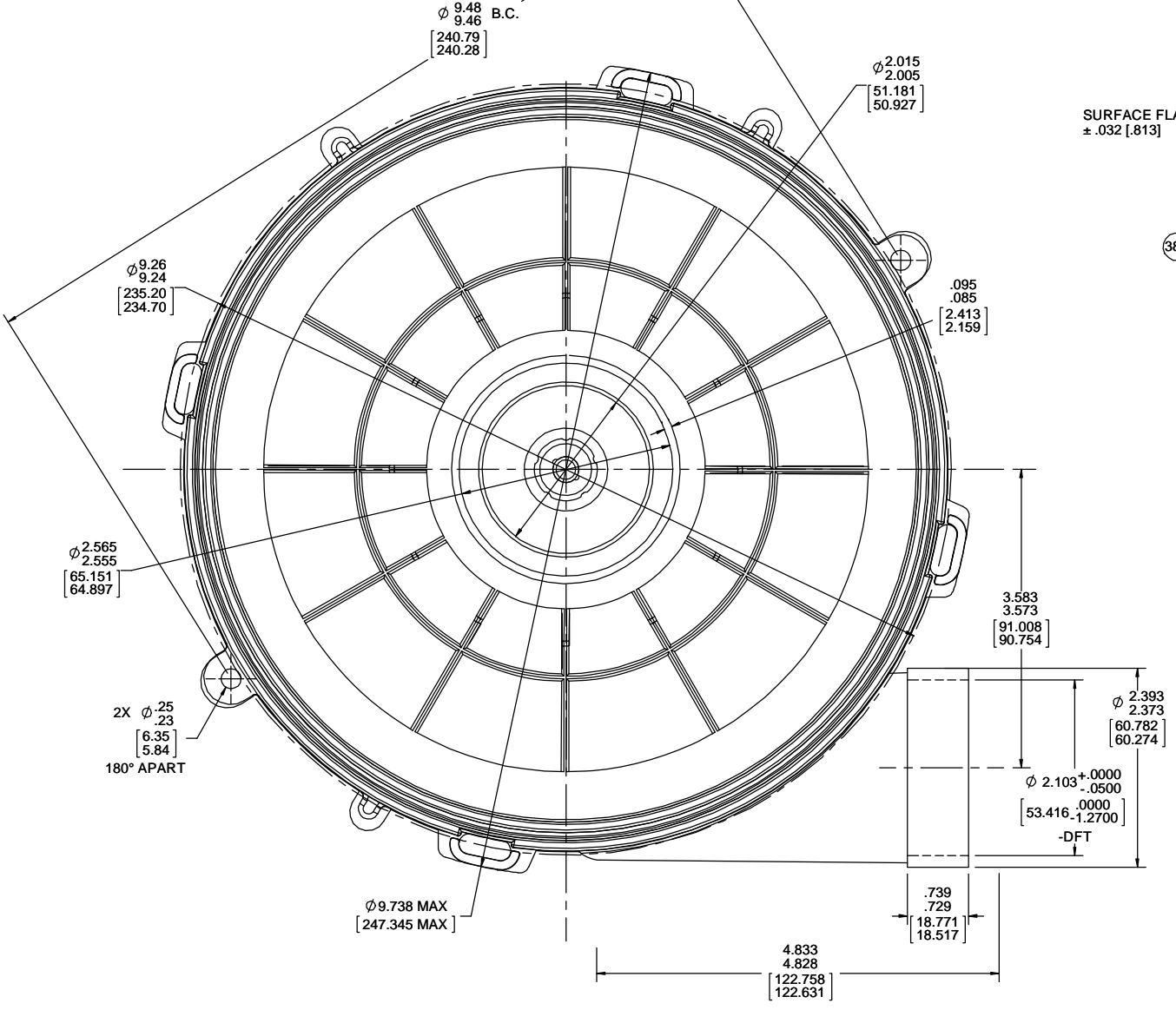
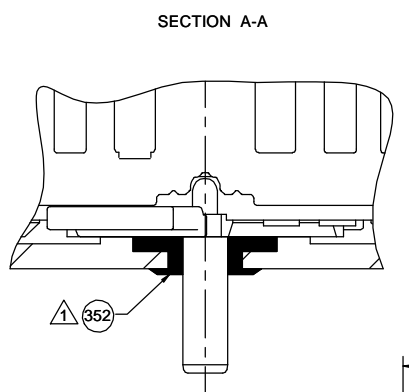

FASCO NO. 702111845
Assembled In Mexico
Model A211
61299553

RPM	WATTS	AMPS
3350	160	2.35

DRAWING REVISION	REVISION BY	DATE	12/14/2017
ECO-0135786	PLA	DATE	12/14/2017
ECO DESCRIPTION	APPROVED BY	SAA	
ADDED GASKET NOTE TO PACKING NOTE			
PROPRIETARY AND CONFIDENTIAL INFORMATION - THIS DOCUMENT IS THE PROPERTY OF REGAL BELOIT AMERICA, INC. CORP. AND CONTAINS OWNERS PROPRIETARY INFORMATION. ANY PERSON, CORPORATION OR OTHER FIRM RECEIVING IT IS DEEMED, BY RECEIVING IT, TO AGREE THAT IT, AND/OR ANY PART OF IT, SHALL NOT BE DISCLOSED TO ANY PERSON, CORPORATION OR OTHER ENTITY, DUPLICATED, AND/OR USED, EXCEPT AS EXPRESSLY APPROVED IN WRITING IN ADVANCE BY OWNER. THIS DOCUMENT SHALL BE RETURNED TO OWNER UPON REQUEST. IT MAY BE SUBJECT TO CERTAIN RESTRICTIONS UNDER APPLICABLE EXPORT CONTROL LAWS AND REGULATIONS.			
BLOWER WEIGHT	5.25 LBS.		ENDPLAY .XX/.XX

TOLERANCES UNLESS OTHERWISE SPECIFIED:	DRUN BY	SDM
DEC. INCH .001	DATE	2/20/2015
.XX ±0.01	APPROVED BY	BGP
.XXX ±0.005	DATE	2/20/2015
XXXX ±0.0005	REFERENCE	
REMOVE BURRS & BREAK SHARP EDGES: .003 [.076] X 45°	MATERIAL	SEE NOTE 7
CORNER FILLETS: R.02 [51]	PROCESS/FINISH	SEE NOTE 7
MACHINED SURFACES: 125 INCH/INCH	SIZE	D
mm SHOWN IN [BRACKETS]	DRAWING NUMBER	702111845
THIRD ANGLE PROJECTION	PROJECT	SEE NOTE 7
3/2	PROJECT	SEE NOTE 7
1	SHEET	1 OF 1

Regal Beloit America, Inc.

BLOWER ASSY