

THERMALLY PROTECTED  
CLASS "B" INSULATION  
416/420 SS SHAFT  
SEALED BALL BEARING

APPLICATION:	GAS FURNACE	B	LA	FR	A	S	C	E	B	A
CUSTOMER:	FASCO DIST.	GS	58	48	X	17	XX	5	0	4
CUSTOMER PN:	A198									

- NOTES:
- NO STA-LOC REQUIRED ON IMPELLER.
  - INSPECTION TEST FIXTURING IS REQUIRED.
  - 100% HIPOT 1500V FOR 1 SECOND.
  - 100% RUN, WITH 1" INLET RESTRICTOR & TEST FOR AMP DRAW.
  - AUDIT VIBRATION PERIODICALLY TO INSURE .0015 MAX. DISPLACEMENT.
  - IMPELLER MEASURED FROM BACK PLATE OF IMPELLER TO INSIDE OF HOUSING .150/.130 [3.810/3.302].
  - PACK 1 PER CONTAINER, 9 CONTAINERS PER LAYER, 4 LAYERS PER PALLET, 36 MAX. AMOUNT PER PALLET, PER PACKING ASSY. 87854752. SEE 88834200.
  - CARTON LABELS MUST FACE ONE DIRECTION TOWARD THE OPEN END OF PALLET. SEE 88834408.
  - NO PACKAGING TAPE OVER CARTON LABEL.
  - APPLY NAMEPLATE LABEL TO MOTOR TO READ RIGHT FROM BACK END OF MOTOR.
  - SERIALIZED NUMBER.

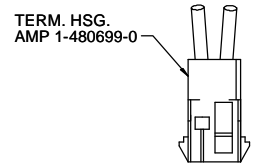

PIN 1 BLACK  
PIN 2 WHITE

LEAD MATERIAL  
18 GA. 125°C, 2/64 INSUL.  
X-LINKED POLY.  
BLACK & WHITE  
6.50/5.50 [165.10/139.70]  
TO BACK OF TERM. HSG.  
W/PIN TERMS. AMP 350218-1

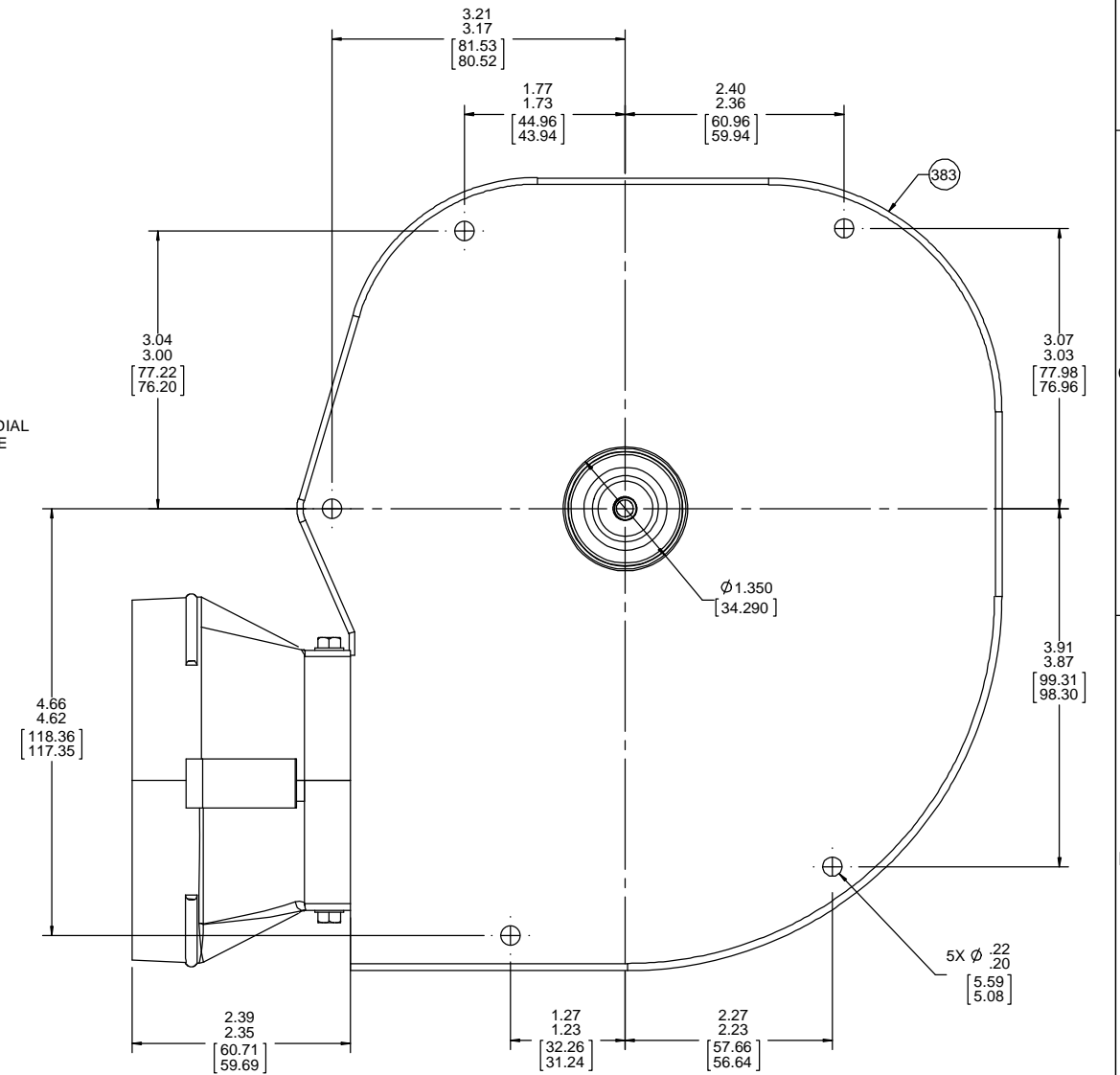
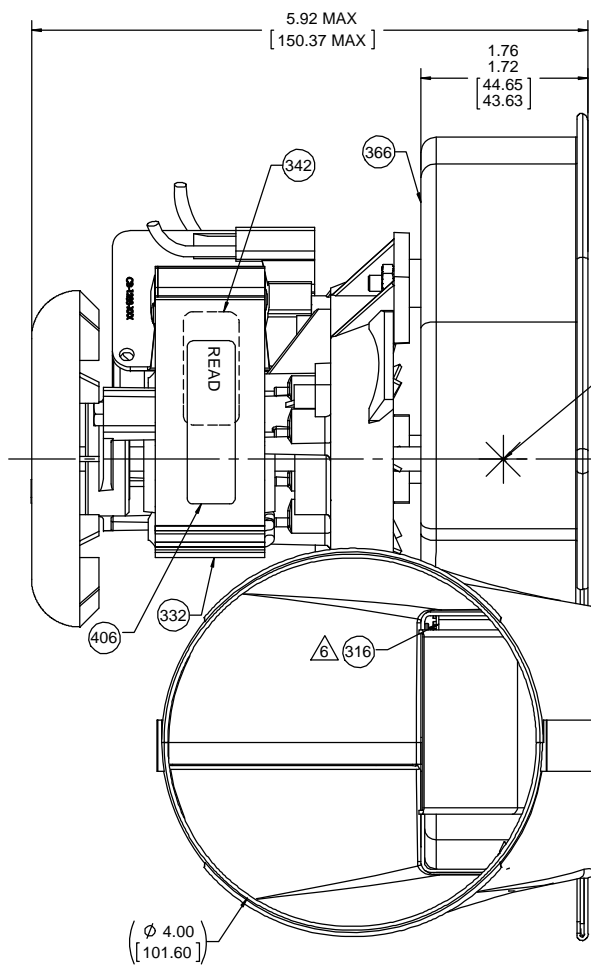
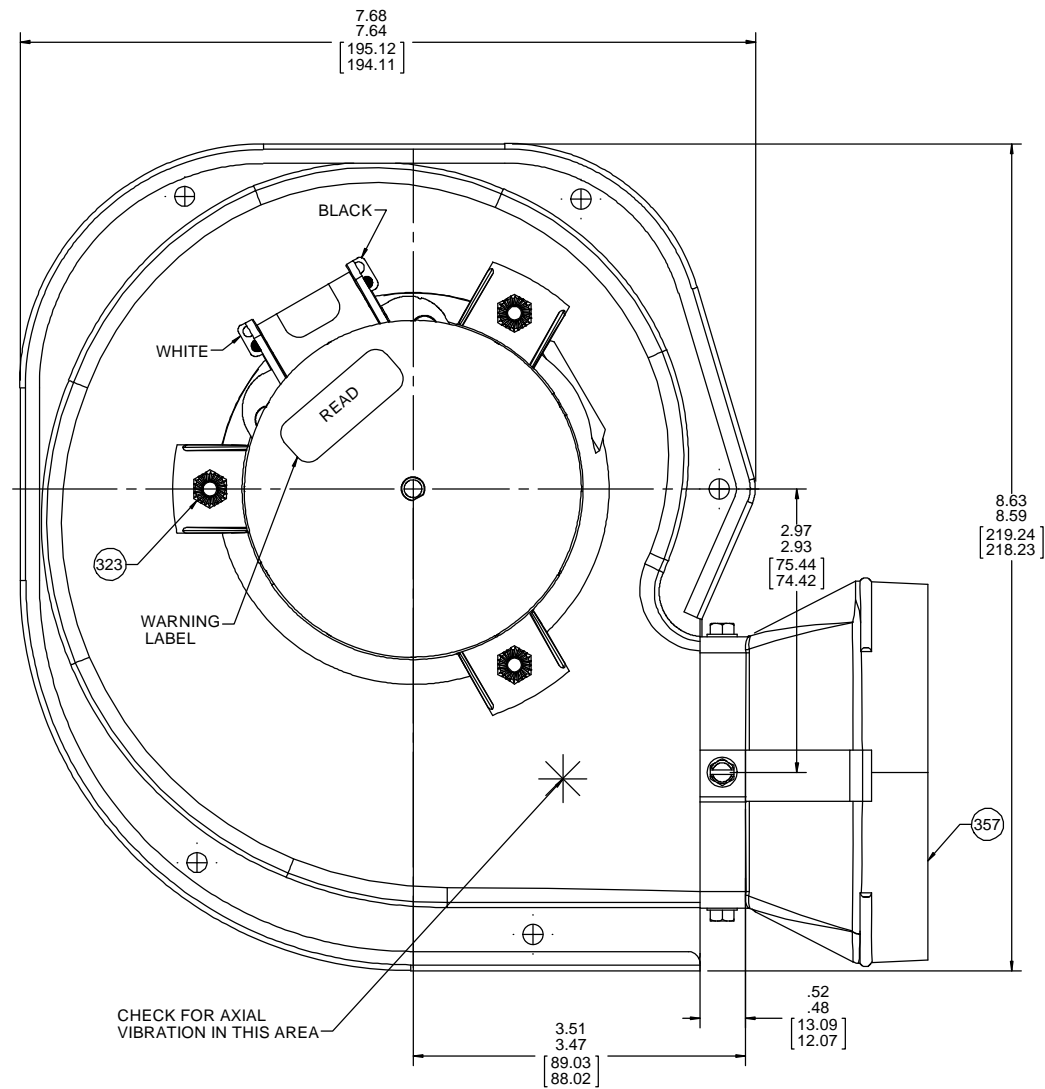

10 61305656

11

**FASCO** No. 70580445

Assembled in Mexico

Cust P/N A260

61305568

**SAFETY WARNING**  
This motor must be grounded in accordance with local or national electrical codes to prevent possible injury due to electrical shock.

**AVERTISSEMENT DE SÉCURITÉ**  
Ce moteur doit être fondée sur conformément à la réglementation locale ou nationale électrique codes pour prévenir d'éventuelles blessures en raison de choc électrique.

61304322

**US PATENT:**  
6314894, 6318358, 6468034  
6494152, 6595146, 6895874  
6902373, 6908281, 6929448

TYPICAL PERFORMANCE TEST DATA  
WITH 1" INLET RESTRICTOR  
AT 115 VOLTS 60 Hz

MOTOR USED	RPM	WATTS	AMPS
71580164	3250	56	1.03
71581445	3267	68	1.23

BLOWER WEIGHT 4.75 LBS.

ENDPLAY .XX/.XX

DRAWING REVISION EA	REVISION BY FDP	DATE 11/1/2017	TOLERANCES UNLESS OTHERWISE SPECIFIED: DEC. INCH mm ANGLE ±1°	DRAWN BY RPT
ECO-0133934	APPROVED BY KSA	DATE 11/1/2017	.XX ±0.01 [±0.25] .XXX ±0.005 [±0.127] XXXX ±0.0005 [±0.0127]	DATE 09/16/2015
<p>REGAL BELLOIT AMERICA, INC. CONFIDENTIAL PROPRIETARY INFORMATION. THIS DOCUMENT IS THE PROPERTY OF REGAL BELLOIT AMERICA, INC. CONSENT AND CONFIRMATION OF OWNERS PROPRIETARY INFORMATION. ANY PERSON, CORPORATION OR OTHER FIRM RECEIVING IT IS DEEMED, BY RECEIVING IT, TO AGREE THAT IT, AND/OR ANY PART OF IT, SHALL NOT BE DISCLOSED TO ANY PERSON, CORPORATION OR OTHER ENTITY, DUPLICATED, AND/OR USED, EXCEPT AS EXPRESSLY APPROVED IN WRITING IN ADVANCE BY OWNER. THIS DOCUMENT SHALL BE RETURNED TO OWNER UPON REQUEST. IT MAY BE SUBJECT TO CERTAIN RESTRICTIONS UNDER APPLICABLE EXPORT CONTROL LAWS AND REGULATIONS.</p>			APPROVED BY BGP	DATE 09/16/2015
<p>UPDATED MOTOR TEST PERFORMANCE</p>			REMOVE BURRS & BREAK SHARP EDGES: .003/.015 [0.076/.381] X 45° CORNER FILLETS: R.02 [51] MACHINED SURFACES: 125 INCR/3.2 mm SHOWN IN [BRACKETS]	DESCRIPTION BLOWER ASSY
<p>REGAL BELLOIT AMERICA, INC.</p>			MATERIAL	PROCESS/FINISH
<p>THIRD ANGLE PROJECTION</p>			SIZE	DRAWING NUMBER
<p>1 OF 1</p>			D	70580445