

THERMALLY PROTECTED
CLASS "B" INSULATION
SEALED BALL BEARING
416 SS SHAFT

APPLICATION:	FURNACE	B	LA	FR	A	S	C	E	B	A
CUSTOMER:	FASCO DIST.	PS	21	47	F	06	CK	5	0	0
CUSTOMER PN:	A178	FINISH: BLOWER-NATURAL, MOTOR-FLAT BLACK								

NOTES:

- ASSEMBLE PC 352 SEAL BEFORE MOTOR HAS BEEN ASSEMBLED.
- INSPECTION TEST FIXTURE IS REQUIRED.
- ALL UNITS TO BE 100% TESTED ON AUTOMATIC TEST FIXTURES PER TEST LIMITS ESTABLISHED IN THE TESTER DATA BASE.
- ALL UNITS TO BE CHECKED 100% FOR VACUUM TAP. TEST 1 OF 20 FOR LEAKAGE.
- STATIC TAP READING IS TO BE -2.0 MINIMUM CORRECTED TO STANDARD AIR (0.075 LB/FT³) WITH A 1.25" INLET RESTRICTOR.
- ASSEMBLE PC 394 END CAP OVER STATIC TAP.
- PACK 1 PER CONTAINER, 36 MAX. PER PALLET. PACKING ASSY. 87854866. 12 CONTAINERS PER LAYER, 3 LAYERS PER PALLET, PER 88834200 AND 88834408.
- CARTON LABELS MUST ALL FACE ONE DIRECTION TOWARD THE OPEN END OF THE PALLET. SEE 88834408.
- NO PACKAGING TAPE OVER CARTON LABEL.

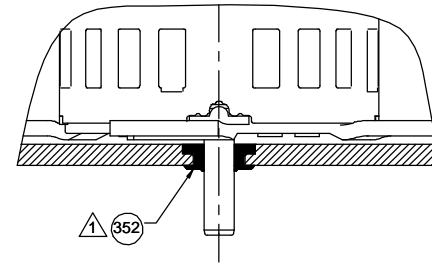

SECTION A - A

LEAD MATERIAL
18 GA. 125°C 2/64 INSUL.
EPDM. (1) WHITE, (1) BLACK
12.50/10.50 [317.50/266.70]
MSPADE TERMS.
AMP 2-520102-2

GROUND LEAD MATERIAL
18 GA. 125°C 2/64 INSUL.
X-LINKED POLY., GRN/YEL
16.00/14.00 [406.40/355.60]
RING TERM.
AMP 40724

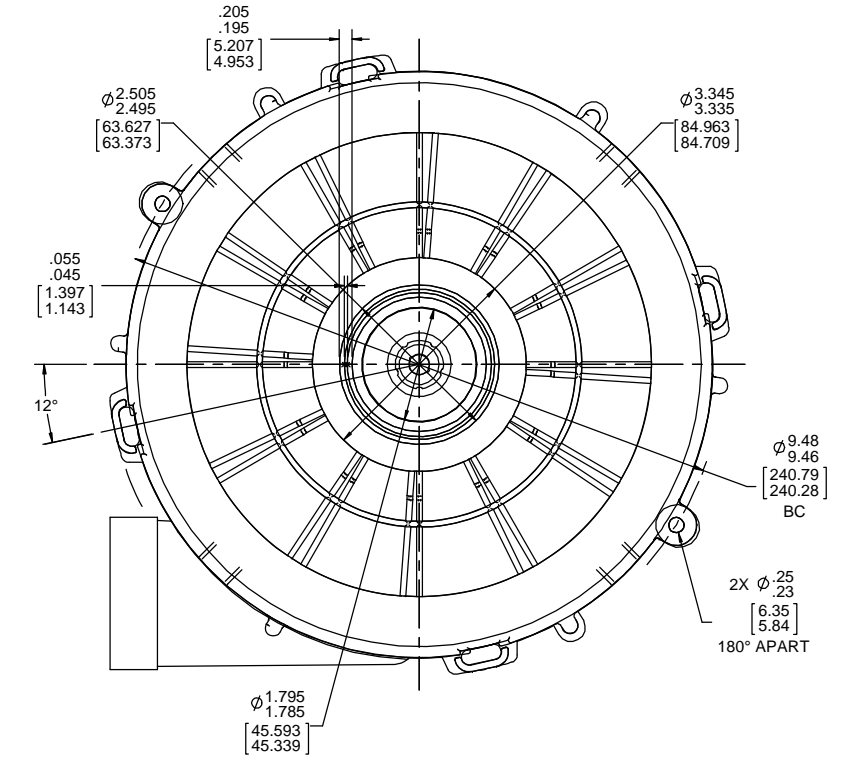
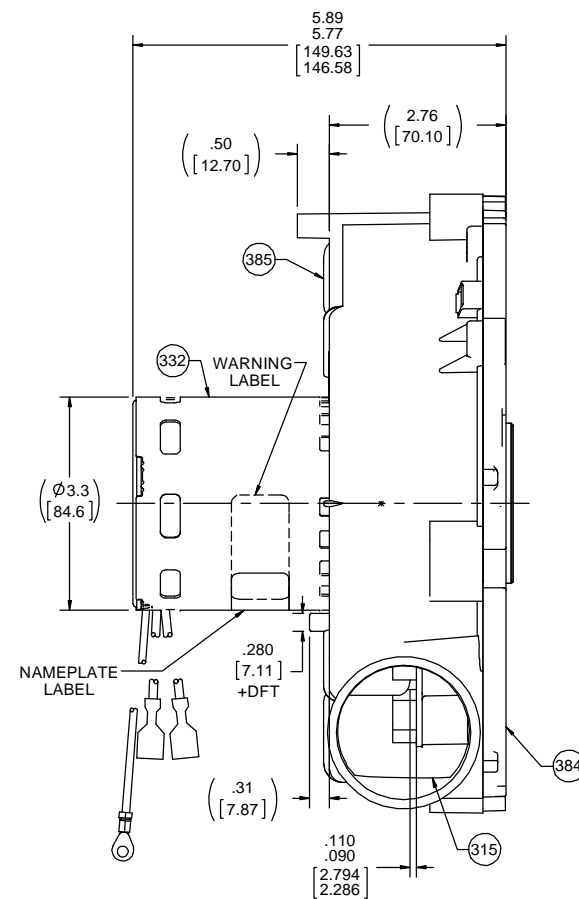
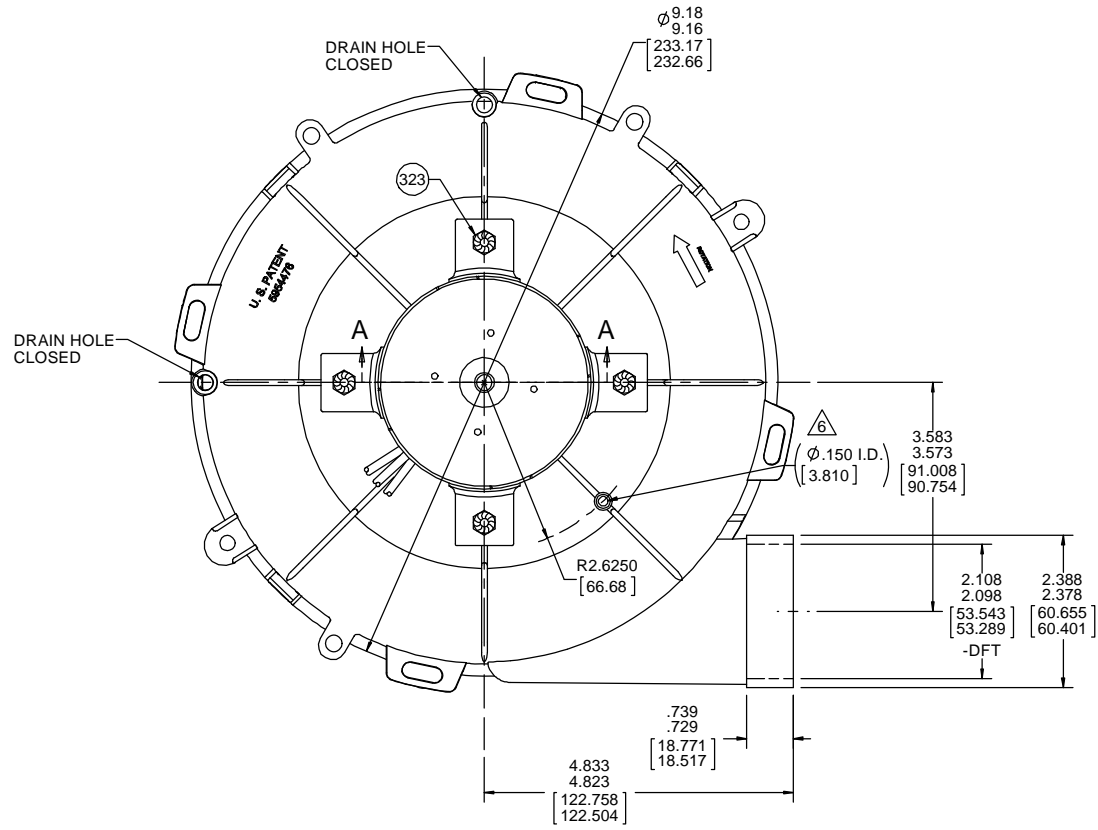

TYPICAL PERFORMANCE TEST DATA		
AT 115 VOLTS 60 Hz		
RPM	WATTS	AMPS
3367	124	1.95
BLOWER WEIGHT LBS.		ENDPLAY .XX/XX

DRAWING REVISION	REVISION BY	DATE	TOLERANCES UNLESS OTHERWISE SPECIFIED:	DRAWN BY
AB	MLS	1/8/2019	DEC. INCH mm ANGLE ±1°	PLA
ECO-0159285	APPROVED BY	DATE	.X ±0.1 [±2.5]	DATE
	SDM	1/8/2019	.XX ±0.01 [±0.25]	1/18/2018
CORRECTED LABEL LOCATIONS TO MATCH MOTOR			APPROVED BY	BAA
<small>PROPRIETARY AND CONFIDENTIAL INFORMATION - THIS DOCUMENT IS THE PROPERTY OF REGAL BELOIT AMERICA, INC. CONCEPT AND CONTENT OWNERS PROPRIETARY INFORMATION, ANY PERSON, CORPORATION OR OTHER FIRM RECEIVING IT IS DEEMED, BY RECEIVING IT, TO AGREE THAT IT AND/OR ANY PART OF IT, SHALL NOT BE DISCLOSED TO ANY PERSON, CORPORATION OR OTHER ENTITY, DUPLICATED, AND/OR USED, EXCEPT AS EXPRESSLY APPROVED IN WRITING IN ADVANCE BY OWNER. THIS DOCUMENT SHALL BE RETURNED TO OWNER UPON REQUEST. IT MAY BE SUBJECT TO CERTAIN RESTRICTIONS UNDER APPLICABLE EXPORT CONTROL LAWS AND REGULATIONS.</small>			DATE	1/18/2018
			REMOVE BURRS & BREAK SHARP EDGES: .003/.015 [0.076/.381] X 45°	DESCRIPTION
			CORNER FILLETS: R.02 [51]	OUTLINE BLOWER ASSY
			MACHINED SURFACES: 125/3.2/3.2	MATERIAL
			mm SHOWN IN [BRACKETS]	PROCESS/FINISH
			THIRD ANGLE PROJECTION	SIZE
			D	DRAWING NUMBER
				702111878
				SHEET
				1 OF 1

