

NOTES:

1. COLD WINDING RESISTANCE: 8.2 OHMS AT 23°C.
2. THERMAL PROTECTED RATING: 120°C T.I. P/N 7AM211A5.
3. BLOWER HOUSING: ALUMINIZED STEEL (NO PAINT)
4. RUNOUT ON REAR COOLING FAN MUST NOT EXCEED 5.70 MAXIMUM OVERALL LENGTH DIMENSION. FAN RUNOUT NOT TO EXCEED ± .050.
5. REAR COOLING FAN MATERIAL: RTP 199X66833. FAN IS SECURED TO SHAFT WITH SPLIT "D" SHAPED HUB AND STEEL COMPRESSION RING.
6. BECKET AIR WHEEL P/N F120-34S.
7. IMPELLER HUB MATERIAL: STEEL
8. BLOWER WHEEL SET SCREW MUST HAVE PLAIN CUP POINT.
9. IMPELLER LOCATION MEASURED FROM INSIDE OF MOTOR SHELL ON DISHED AREA TO BACK OF IMPELLER.
10. TORQUE IMPELLER SET SCREW TO BE 60 IN/LB.
11. INSPECTION TEST FIXTURE IS REQUIRED.
12. STATIC TAP READING TO BE -1.26 TO -1.63 CORRECTED TO STANDARD AIR (0.075 LB/FT³) WITH A 1 5/16" INLET RESTRICTOR.
13. PACK 1 PER CONTAINER, 12 CONTAINERS PER LAYER, 4 LAYERS PER PALLET, 48 MAX. PER PALLET, PACKING ASSY. 87855084, P.S. 88834200 AND P.S. 88834408.
14. CARTON LABELS MUST ALL FACE ONE DIRECTION TOWARD THE OPEN END OF THE PALLET. SEE P.S. 88834408.
15. NO PACKAGING TAPE OVER CARTON LABEL.

APPLICATION DIST.

THERMALLY PROTECTED
CLASS "B" INSULATION
SEALED BALL BEARING
416 S.S. SHAFT

B	LA	FR	A	S	C	E	B	A
GS	58	48	X	17	AU	5	0	0
CUSTOMER								FASCO DIST.
CUSTOMER PART NO.								A157

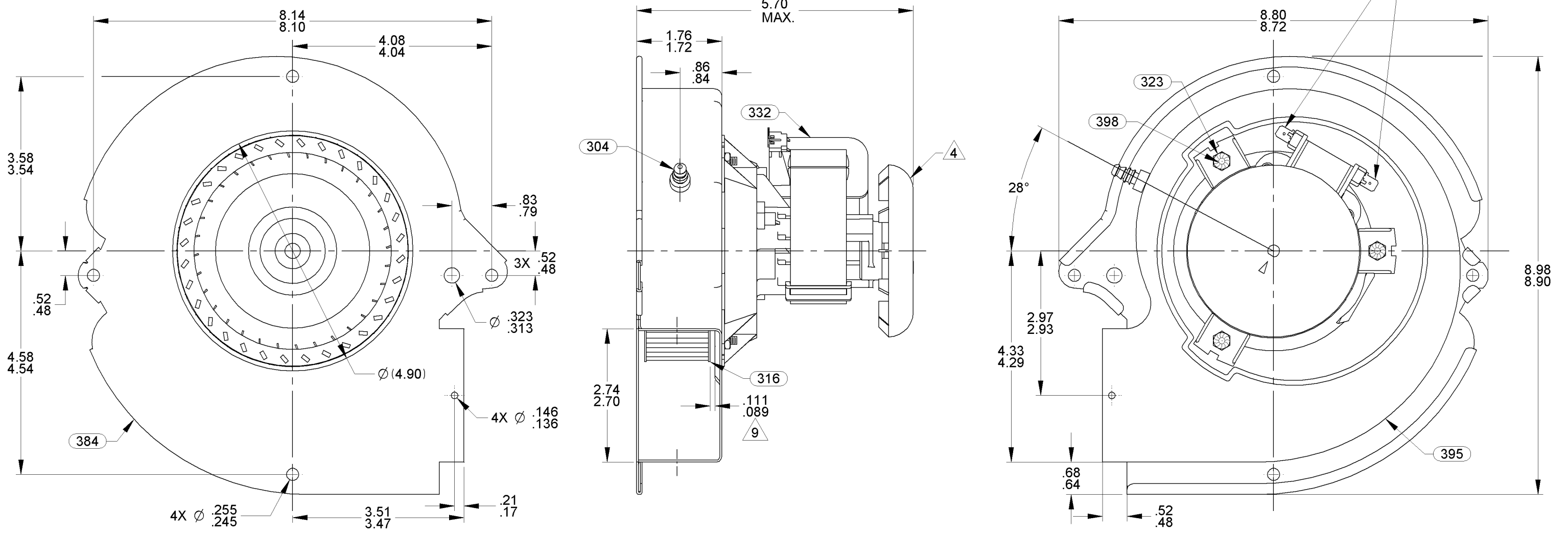

MAG-MATE TERMINAL
89034109
AMP 63128-3 (2X)

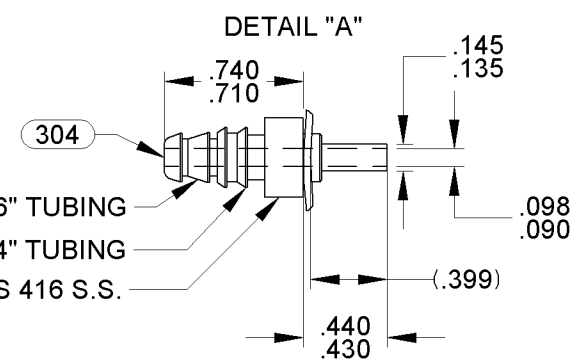

TYPICAL PERFORMANCE TEST DATA WITH 1 5/16 INCH INLET RESTRICTOR

ECO. NO.	REV.	DATE	APPROVAL
4003552	04	10/26/11	PLA/SED
4004075	05	12/16/11	MLM/SED
4008105	06	5/14/2013	SDM/BGP
4010097	07	8/21/2013	SDM/PLA

AT 115 VOLTS 60 HZ.		
R.P.M.	WATTS	AMPS
3163	64	1.04
BLOWER WEIGHT 4.75 LBS.		END PLAY .XX/XX

UNLESS OTHERWISE SPECIFIED DIMENSIONS ARE IN INCHES TOLERANCES ARE:
 FRACTIONS ± 1/16
 DECIMALS XX ± .01
 XXX ± .005
 ANGLES ± 1°

APPROVALS	DATE
DRAWN BGP	03/26/2009
CHECKED PLA	03/26/2009
FINISH COLOR NATURAL	

FASCO FASCO MOTORS GROUP
AC MOTOR/BLOWER DIVISION

CONFIDENTIAL: DO NOT DUPLICATE OR DISCLOSE TO THIRD PARTIES WITHOUT WRITTEN PERMISSION OF FASCO MOTORS GROUP, AC MOTOR/BLOWER DIVISION.

TITLE BLOWER ASSEMBLY		
SIZE B	DWG. NO. 7058 1227	REV. 07
DO NOT SCALE DRAWING		SHEET 1 OF 1