

THERMALLY PROTECTED
CLASS "B" INSULATION
416 SS SHAFT

APPLICATION:		B	LA	FR	A	S	C	E	B	A
CUSTOMER:	FASCO DIST.	06	21	47	V	01	OC	5	3	0
CUSTOMER PN:	A138	FINISH: BLOWER-NATURAL, MOTOR-BLACK								

- NOTES:
1. STATIC TAP TO BE TIGHT AND SECURELY FASTENED.
 2. USE A .125 [3.175] GAGE BETWEEN MOTOR SIDE OF HOUSING AND IMPELLER.
 3. INSPECTION TEST FIXTURE IS REQUIRED.
 4. WITH 98 VOLTS APPLIED, SHAFT MUST MAKE THREE UNINTERRUPTED REVOLUTIONS.
 5. 100% CHECK STATIC TAP READING IS TO BE -.87 MINIMUM CORRECTED TO STANDARD AIR (0.075 LB/FT³) WITH A Ø2 1/16 INLET RESTRICTOR.
 6. PACK 1 PER CONTAINER, 30 CONTAINERS PER LAYER, 5 LAYERS PER PALLET, 150 MAX. PER PALLET, PACKING ASSY: 87855523, PER 88834200 AND 88834408.
 7. CARTON LABELS MUST ALL FACE ONE DIRECTION TOWARD THE OPEN END OF THE PALLET. SEE 88834408.
 8. NO PACKAGING TAPE OVER CARTON LABEL.

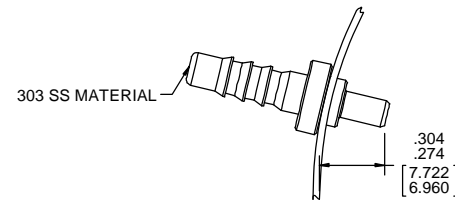

DETAIL A

LEAD MATERIAL
18 GA. 125°C 4/64 INSUL.
EPDM. (2) BLACK
38.00/36.00 [965.20/914.40]
W/PIN TERM.
AMP 350538-1

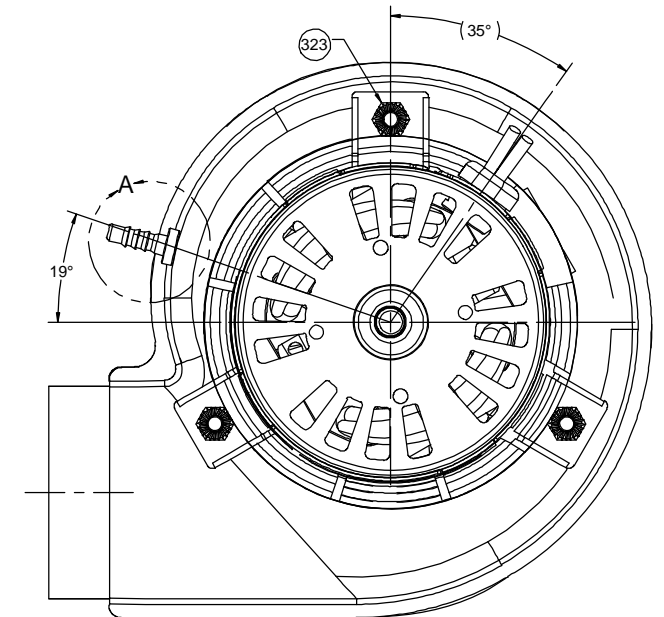
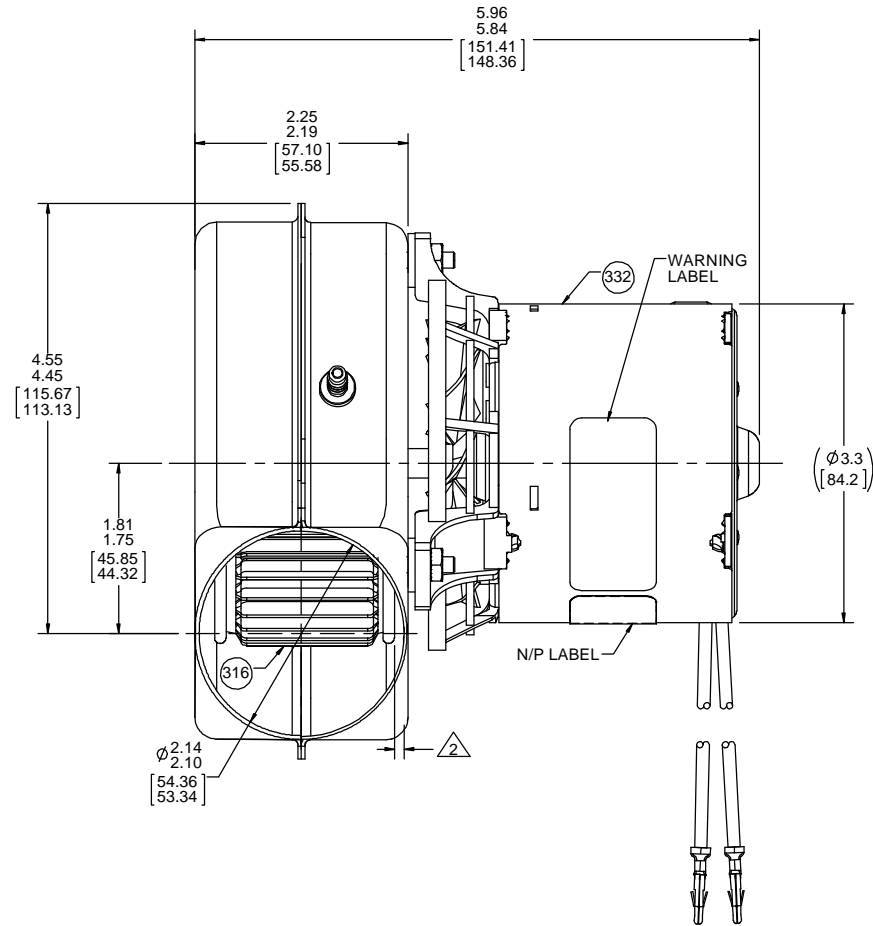
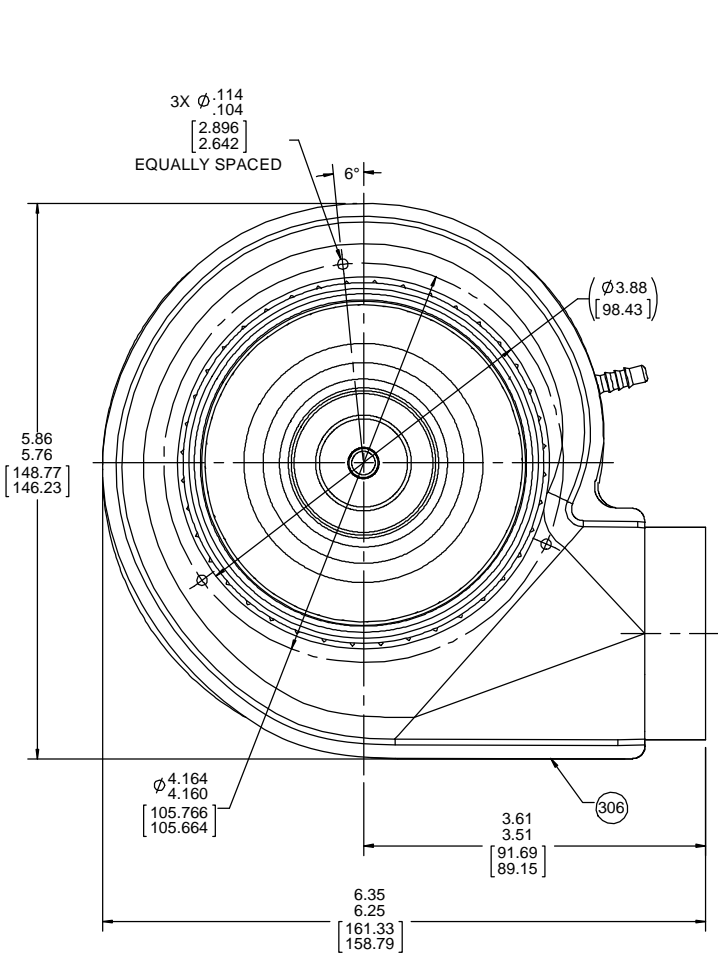

TYPICAL PERFORMANCE TEST DATA WITH A 2 1/16 INLET RESTRICTOR			
AT 120 VOLTS 60 Hz			
	RPM	WATTS	AMPS
	3075	65	.76
BLOWER WEIGHT	4.25 LBS.		ENDPLAY .030/.010 [.762/.254]

DRAWING REVISION AA	REVISION BY MLS	DATE 8/28/2018	TOLERANCES UNLESS OTHERWISE SPECIFIED: DEC. INCH mm ANGLE .X ±0.1 [±2.5] ±1° .XX ±0.01 [±0.25] .XXX ±0.005 [±0.127] XXXX ±0.0005 [±0.0127]	DRAWN BY MLS	DATE 8/28/2018	DESCRIPTION OUTLINE BLOWER ASSY
ECO ECO-0151146	APPROVED BY SDM	DATE 8/28/2018	REMOVE BURRS & BREAK SHARP EDGES: .003/.015 [0.076/.381] X 45° CORNER FILLETS: R.02 [.51] MACHINED SURFACES: 125/ INCR/ 32/ mm SHOWN IN [BRACKETS]	APPROVED BY SDM	DATE 8/28/2018	MATERIAL PROCESS/FINISH
<small> PROPRIETARY AND CONFIDENTIAL INFORMATION - THIS DOCUMENT IS THE PROPERTY OF REGAL BELOIT AMERICA, INC. CONSENT AND CONFIRMATION OWNERS PROPRIETARY INFORMATION, ANY PERSON, CORPORATION OR OTHER FIRM RECEIVING IT IS DEEMED, BY RECEIVING IT, TO AGREE THAT IT, AND/OR ANY PART OF IT, SHALL NOT BE DISCLOSED TO ANY PERSON, CORPORATION OR OTHER ENTITY, DUPLICATED, AND/OR USED, EXCEPT AS EXPRESSLY APPROVED IN WRITING IN ADVANCE BY OWNER. THIS DOCUMENT SHALL BE RETURNED TO OWNER UPON REQUEST. IT MAY BE SUBJECT TO CERTAIN RESTRICTIONS UNDER APPLICABLE EXPORT CONTROL LAWS AND REGULATIONS. </small>			THIRD ANGLE PROJECTION 	DRAWING NUMBER 70219410	SHEET 1 OF 1	

REGALTM Regal Beloit America, Inc.

OUTLINE
BLOWER ASSY

DRAWING NUMBER
70219410

SHEET
1 OF 1