

NOTES:

1. ASSEMBLE GROUND STRAP TO HOUSING WITH PC. 325 SCREW.
2. NO STA-LOC REQUIRED ON IMPELLER
3. IMPELLER SPECIFICATIONS : (A) STATICALLY BALANCED TO .020 OZ. -IN. MAX., (B) O.D. OF WHEEL CONCENTRIC TO .025" MAX T.I.R. (C) MAX. AXIAL RUNOUT AT EDGE OF WHEEL .015".
4. DO NOT SUBSTITUTE IMPELLER.
5. PACK 1 PER CONTAINER, 60 MAX, PER PALLET, PACKING ASSY: 87854335, 12 CARTONS PER LAYER, 5 LAYERS PER PALLET, P.S. 88834200 AND P.S. 88834408.
6. INSPECTION TEST FIXTURE IS REQUIRED.
7. CARTON LABELS MUST ALL FACE ONE DIRECTION TOWARD THE OPEN END OF THE PALLET. SEE P.S. 88834408.
8. NO PACKAGING TAPE OVER CARTON LABEL.

APPLICATION	FURNACE								
THERMALLY PROTECTED CLASS "B" INSULATION	B	LA	FR	A	S	C	E	B	A
416 S. S. SHAFT	18	21	47	V	06	OU	5	3	0
LEAD MATERIAL	CUSTOMER FASCO DIST.								
18 GA. 125°C 4/64 INSUL.	CUSTOMER PART NO. A118								
EPDM. BLACK AND WHITE	GROUND LEAD								
12.00/10.00 IN. LONG	18 GA. 125°C 2/64 INSUL.								
W/SOCKET TERMS. 89036006	X-LINKED POLY. GRN/YEL								
AMP 350537-1	8.00/6.00 IN. LONG								
	W/RING TERM. 89020156								
	AMP 61794-1								

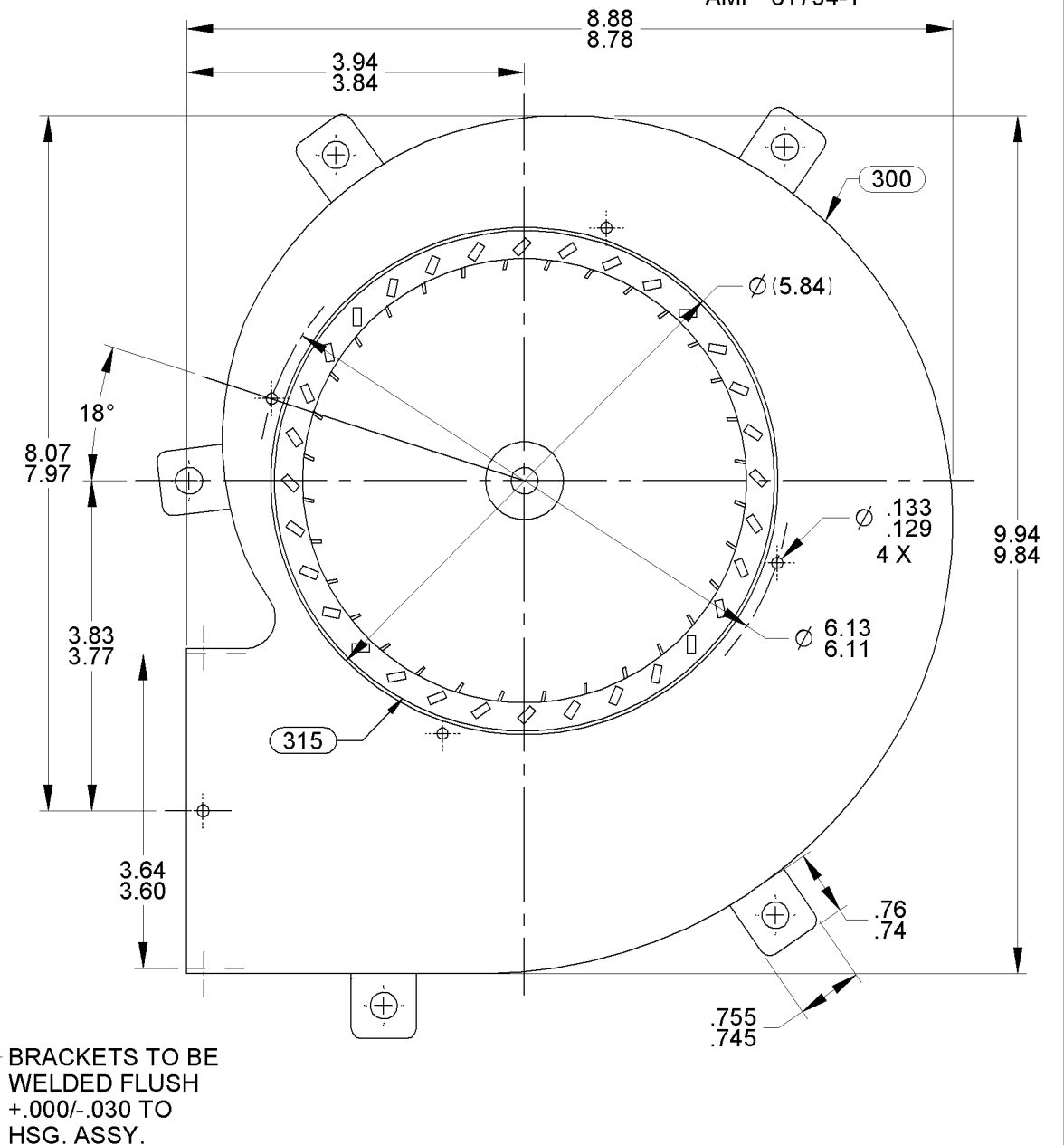
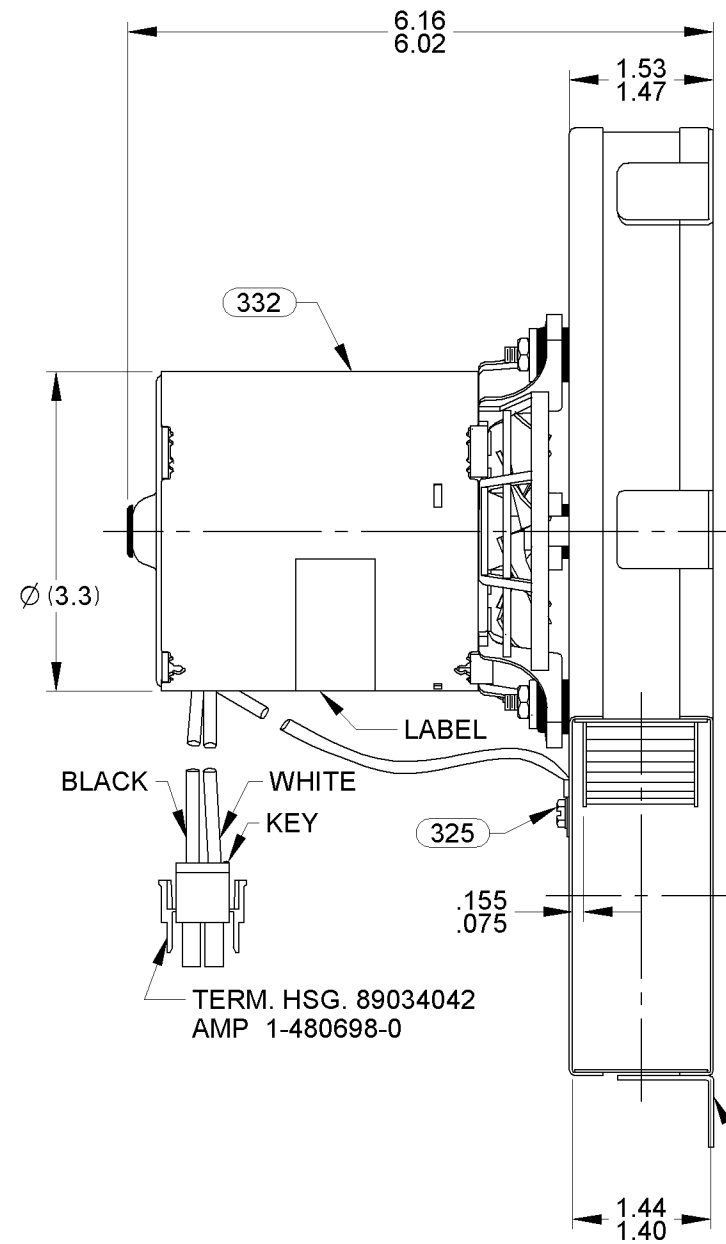
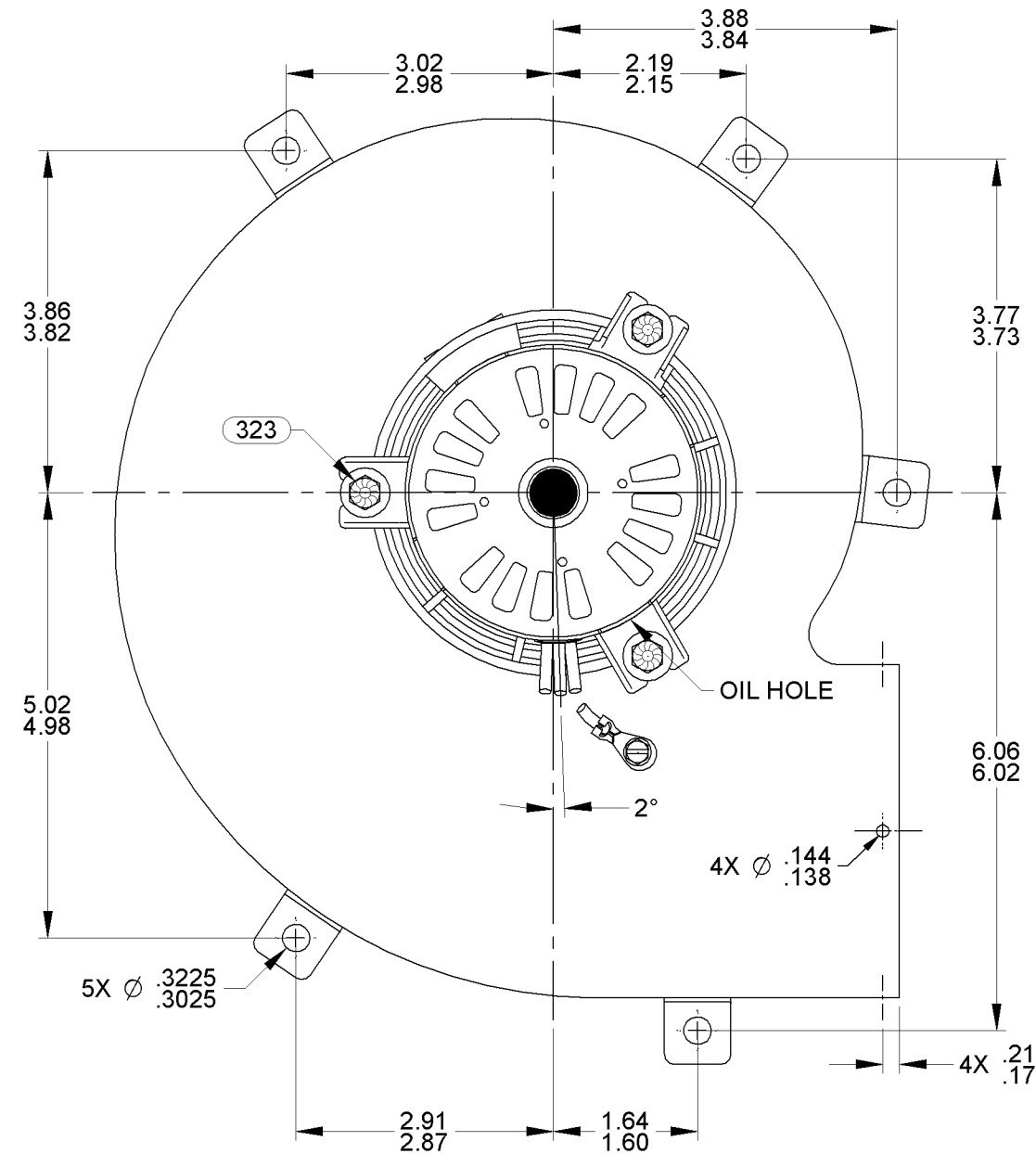
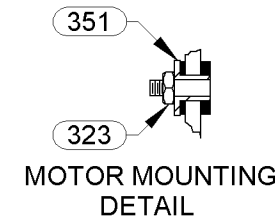

TYPICAL PERFORMANCE TEST DATA WITH 2 INCH INLET RESTRICTOR			
AT	115	VOLTS	60 HZ.
	R.P.M.	WATTS	AMPS

UNLESS OTHERWISE SPECIFIED DIMENSIONS ARE IN INCHES TOLERANCES ARE:		
FRACTIONS ± 1/16	DECIMALS XX ± .01	ANGLES XXX ± .005

FASCO FASCO MOTORS GROUP
AC MOTOR/BLOWER DIVISION

ECO. NO.	REV.	DATE	APPROVAL
4002170	15	05/26/11	MLM/PLA
4008940	16	4/18/2013	SDM/KSA

BLOWER WEIGHT	6 1/2 LBS.	END PLAY	.030/.010
---------------	------------	----------	-----------

APPROVALS	DATE
DRAWN MLM	4/11/06
CHECKED VLL	4/11/06
FINISH COLOR	FLAT BLACK

CONFIDENTIAL: DO NOT DUPLICATE OR DISCLOSE TO THIRD PARTIES WITHOUT WRITTEN PERMISSION OF FASCO MOTORS GROUP, AC MOTOR/BLOWER DIVISION.

TITLE
BLOWER ASSEMBLY

SIZE **B** DWG. NO. 7021 8477 REV. 16

DO NOT SCALE DRAWING SHEET 1 OF 1

If Printed, this is an Uncontrolled Document.