

NAMEPLATE DATA	
MODEL: 1936870J	
CUST PN: USN1202	
HP: 2.0	SF: 1.20
ROT: CCWPE	
RPM: 3450	
TYPE: CX	CODE: G
FORM: B	FRAME: Y 56 J
VOLTS: 208-230/115	
AMPS:	
MAX AMPS:	
SF AMPS: 11.0-10.2/20.4	
PH: 1	HZ: 60
INS: B	AMB: 50°
DUTY: CONT	
ENCLOSURE: ODP	
THERMALLY PROTECTED	

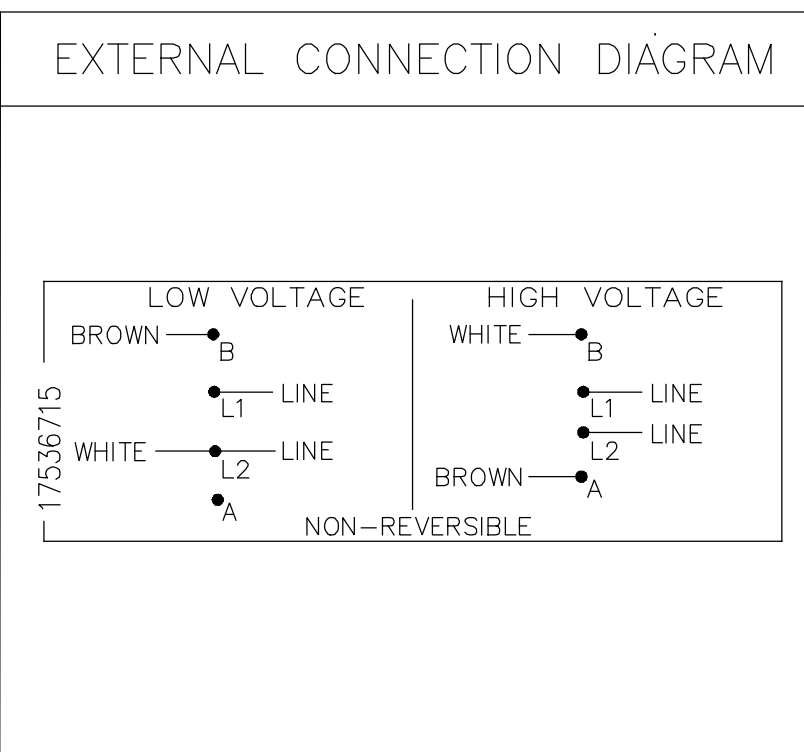

- NOTES
- ⚠ PILOT DIAMETER IS CONCENTRIC WITH SHAFT CENTERLINE WITHIN .004[.10] T.I.R.
  - ⚠ FACE OF MOUNTING FLANGE IS PERPENDICULAR TO SHAFT CENTERLINE WITHIN .004[.10] T.I.R.
  - 3. SHAFT RUNOUT NOT TO EXCEED .002[.05] T.I.R.
  - 4. FOR THREADED SHAFT EXT. MATING, PARTS SHOULD BE RELIEVED ONE THREAD TO CLEAR FILLET.
  - 5. FOR THREADED SHAFT EXT. ECCENTRICITY OF THREADED PORTION OF SHAFT IS HELD WITHIN .004[.10] TOTAL GAUGE READING WITH THE INDICATOR ON O.D. OF GROUND RING GAGE AS SHOWN. THE GAGE BEING STATIONARY WITH RESPECT TO THE ROTOR.
  - 6. END PLAY NOT TO EXCEED .010[.25] MEASURED WITH NO THRUST.
  - ⚠ FRONT END FRAME TO BE ALIGNED WITH BACK END FRAME TO WITHIN ±1° RADIAL ALIGNMENT ±.060[±1.52]
  - 8. ● = CRITICAL DIMENSION

PERFORMANCE CURVE	APPROVED SAMPLE		
19244611			
UL COMPONENT	CSA		
FILE#	CCN#	FILE#	GUIDE#
PENDING	PENDING	PENDING	PENDING
CUSTOMER	DISTRIBUTION		

REVISION	REVISION BY	DATE	TOLERANCES UNLESS OTHERWISE SPECIFIED
C	G. RODRIGUEZ	05-02-2019	DEC. INCH mm ANGLE
ECO	APPROVED BY	DATE	.XX ±0.1 [±2.5] ±0.5°
ECO-0165900	G. RODRIGUEZ	05-02-2019	.XX ±0.02 [±0.51]
ECO DESCRIPTION			.XXX ±0.005 [±0.127]
SEE ECO			.XXXX ±0.0005 [±0.0127]

COPYRIGHT REGAL BELOIT AMERICA, INC. ALL RIGHTS RESERVED. PROPRIETARY AND CONFIDENTIAL INFORMATION - THIS DOCUMENT IS THE PROPERTY OF REGAL BELOIT AMERICA, INC. (OWNER) AND CONTAINS OWNER'S PROPRIETARY INFORMATION. ANY PERSON, CORPORATION OR OTHER FIRM RECEIVING IT IS DEEMED, BY RECEIVING IT, TO AGREE THAT IT, AND/OR ANY PART OF IT, SHALL NOT BE DISCLOSED TO ANY PERSON, CORPORATION OR OTHER ENTITY, DUPLICATED, AND/OR USED, EXCEPT AS EXPRESSLY APPROVED IN WRITING IN ADVANCE BY OWNER. THIS DOCUMENT SHALL BE RETURNED TO OWNER UPON REQUEST. IT MAY BE SUBJECT TO CERTAIN RESTRICTIONS UNDER APPLICABLE EXPORT CONTROL LAWS AND REGULATIONS.

DRAWN BY:	TH	DATE:	10-27-2010
APPROVED BY: <td>TZ <td>DATE: <td>10-27-2010</td> </td></td>	TZ <td>DATE: <td>10-27-2010</td> </td>	DATE: <td>10-27-2010</td>	10-27-2010
REFERENCE: <td></td> <td>MATERIAL: <td></td> </td>		MATERIAL: <td></td>	
THIRD ANGLE PROJECTION		SIZE DWG NO: <td>C USN1202</td>	C USN1202
		SHEET: <td>1</td>	1

REGAL™ Regal Beloit America, Inc.	
DESCRIPTION:	MODEL-PFHP-56FR OUTLINE
MATERIAL:	PROCESS/FINISH
SIZE DWG NO:	C USN1202
SHEET:	1