

NOTES:

- 1 PILOT DIAMETER IS CONCENTRIC WITH SHAFT CENTERLINE WITHIN .004[.10] T.I.R.
- 2 FACE OF MOUNTING FLANGE IS PERPENDICULAR TO SHAFT CENTERLINE WITHIN .004[.10] T.I.R.
- 3. SHAFT RUNOUT NOT TO EXCEED .002[.05] T.I.R.
- 4. ENDPLAY NOT TO EXCEED .010[.25] MEASURED WITH NO THRUST.
- 5 THE 2X BOTTOM HOLES IN THE MTG FLANGE ARE PARALLEL FROM THE BOTTOM OF THE FEET WITHIN .030[.76]

ALL DIMENSIONS SHOWN IN PARENTHESIS ARE REFERENCE DIMENSIONS. ALL OTHER DIMENSIONS ARE TOLERANCED PER THE FOLLOWING CHART UNLESS OTHERWISE SPECIFIED.

"C" DIM.	= +/- .055[1.40]
SHAFT EXT.	= +/- .034[.86]
LEAD LENGTHS EXTENDED	= +/- 1.00[25.4]
THRU-BOLTS	= +/- .050[1.3]
ANGULAR DIM.	= +/- 2°

SHAFT DETAIL

SCALE: 1.5/1

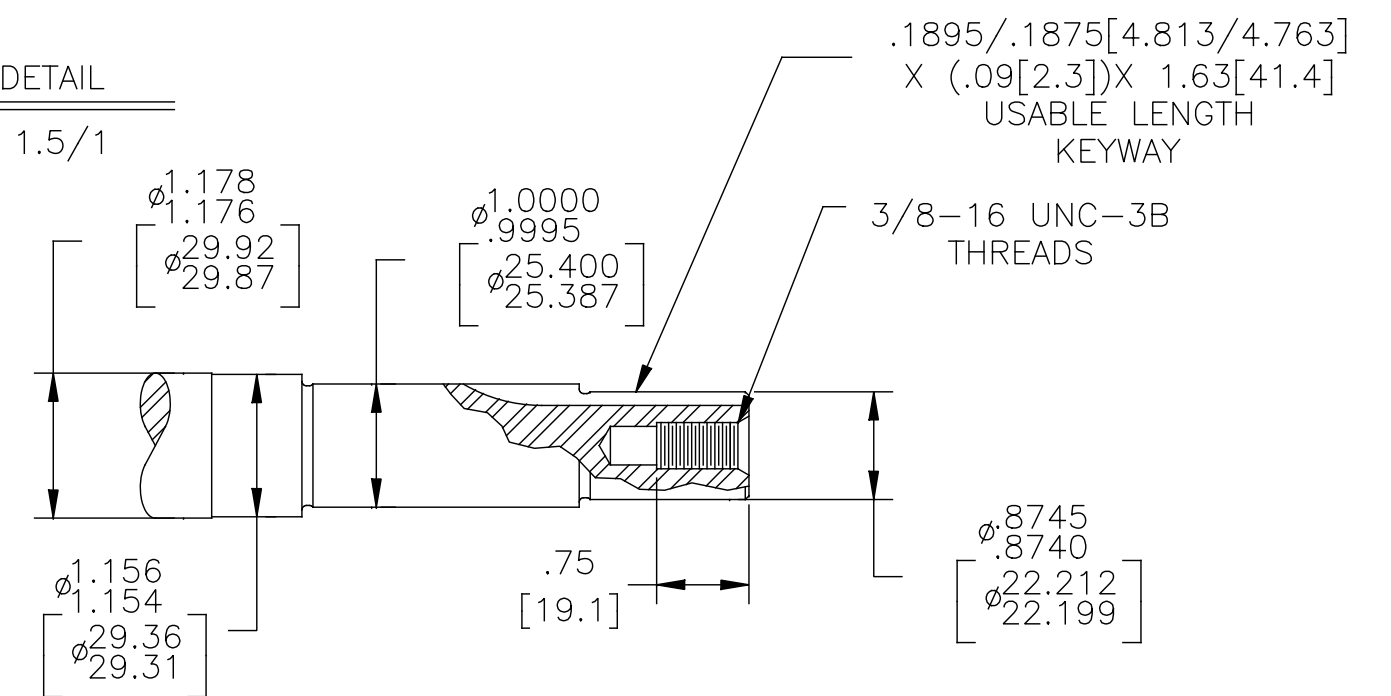

DRAWING REVISION A	REVISION BY MG	DATE 04/16/2016	TOLERANCES UNLESS OTHERWISE SPECIFIED DEC. INCH mm ANGLE .X ±0.1 [±2.5] ±0.5° .XX ±0.02 [±0.51] .XXX ±0.005 [±0.127] .XXXX ±0.0005 [±0.0127]	DRAWN BY: MG	REGAL™ Regal Beloit America, Inc.
ECO ECO-0100498	APPROVED BY MG	DATE 04/16/2016	REMOVE BURRS & BREAK SHARP EDGES .003/.015 [0.076/.381] CORNER FILLETS .02 [51] MACHINED SURFACES 125/INCH 3.2/mm SHOWN IN [BRACKETS]	DATE: 04/16/2016	
ECO DESCRIPTION SEE ECO				APPROVED BY: MG	DESCRIPTION MODEL-IHP OUTLINE
<small>COPYRIGHT REGAL BELOIT AMERICA, INC. ALL RIGHTS RESERVED. PROPRIETARY AND CONFIDENTIAL INFORMATION - THIS DOCUMENT IS THE PROPERTY OF REGAL BELOIT AMERICA, INC. (OWNER) AND CONTAINS OWNER'S PROPRIETARY INFORMATION. ANY PERSON, CORPORATION OR OTHER FIRM RECEIVING IT IS DEEMED, BY RECEIVING IT, TO AGREE THAT IT, AND/OR ANY PART OF IT, SHALL NOT BE DISCLOSED TO ANY PERSON, CORPORATION OR OTHER ENTITY, DUPLICATED, AND/OR USED, EXCEPT AS EXPRESSLY APPROVED IN WRITING IN ADVANCE BY OWNER. THIS DOCUMENT SHALL BE RETURNED TO OWNER UPON REQUEST. IT MAY BE SUBJECT TO CERTAIN RESTRICTIONS UNDER APPLICABLE EXPORT CONTROL LAWS AND REGULATIONS.</small>				DATE: 04/16*2016	MATERIAL
				REFERENCE	PROCESS/FINISH
				THIRD ANGLE PROJECTION	SIZE DWG NO C N157ES
					SHEET 1