

4

3

2

1

GROUP	TYPE	FRAME	FORM	'C' DIM	'BS' DIM
-001	SC	M56H	K	12.69	6.63
-002	SC	U56H	K	12.94	6.88

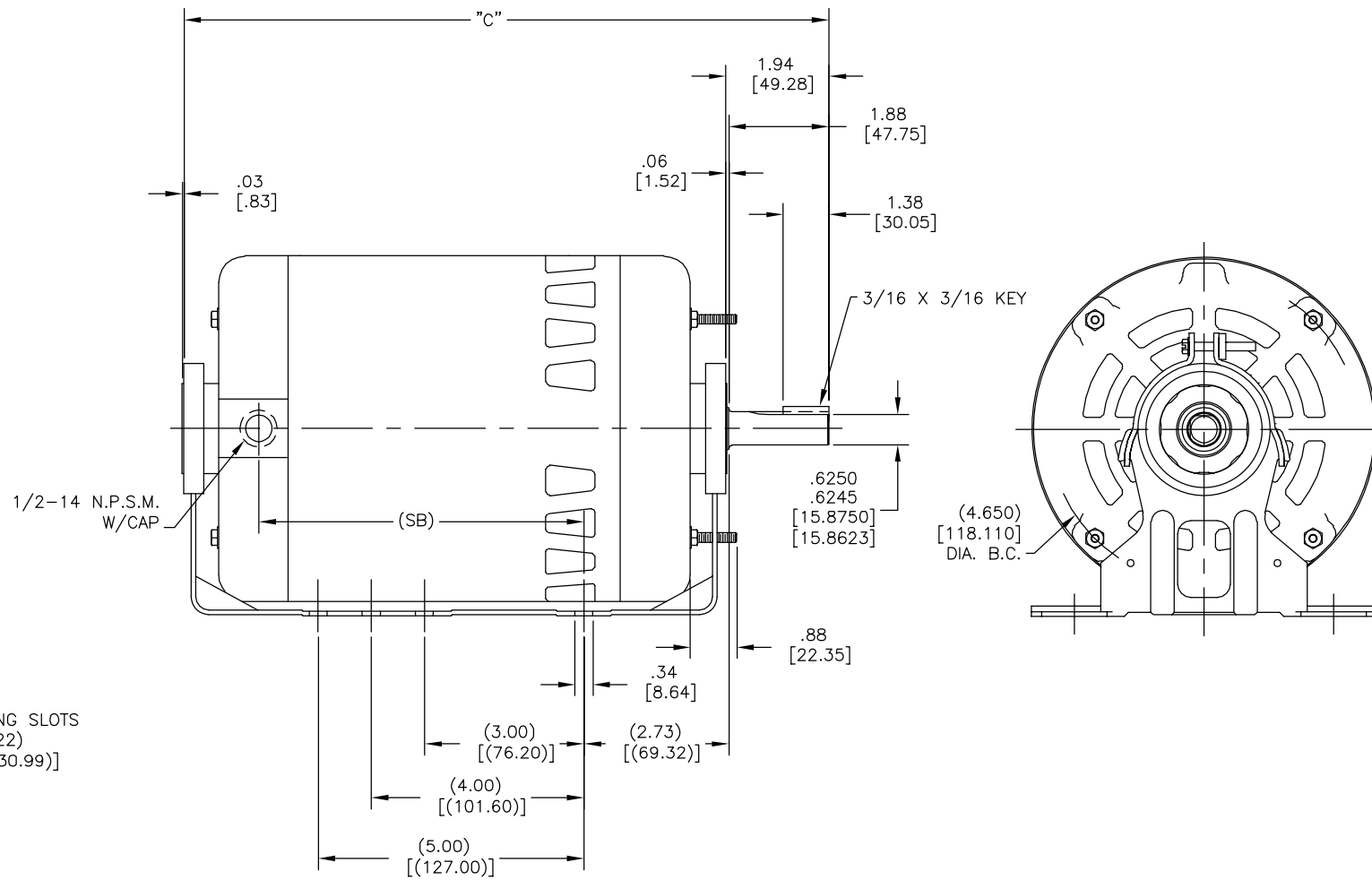
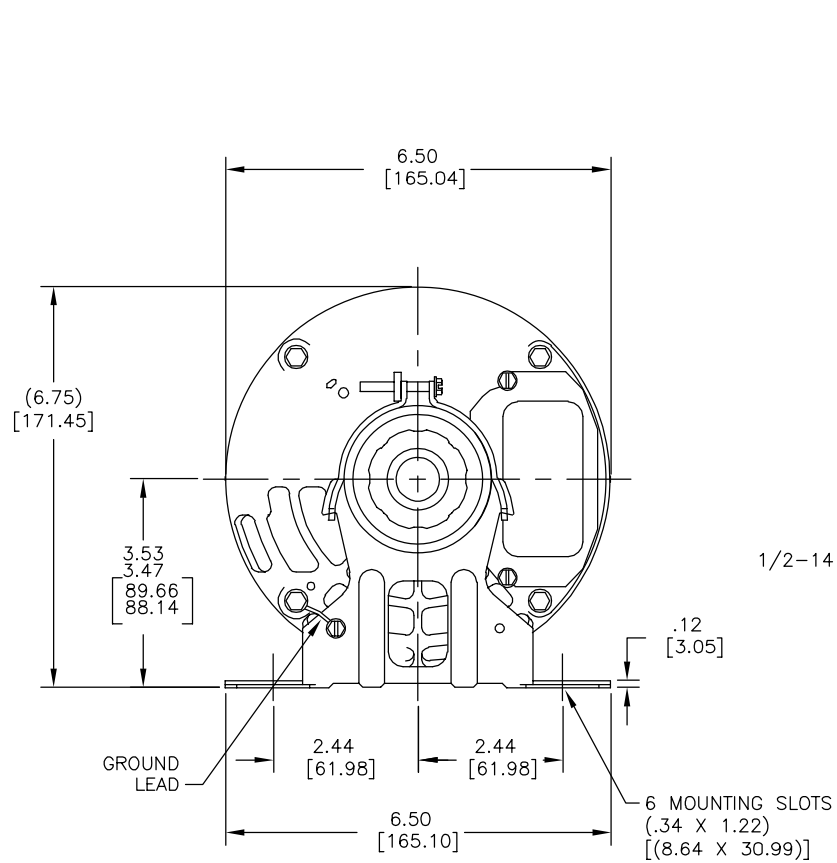

BRACKETS MAY BE OPEN OR ENCLOSED AS REQUIRED ON PROCESS SHEET.

DRAWING REVISION E	REVISION BY D.MENDOZA	DATE 05-14-2014	TOLERANCES UNLESS OTHERWISE SPECIFIED DEC. INCH mm ANGLE .X ±0.1 [±2.5] ±0.5° .XX ±0.02 [±0.51] .XXX ±0.005 [±0.127] .XXXX ±0.0005 [±0.0127]	DRAWN BY: J.BLANK	Regal Beloit America, Inc.
ECO 0051163	APPROVED BY F.PAYAN	DATE 05-14-2014	REMOVE BURRS & BREAK SHARP EDGES .003/.015 [0.076/.381] CORNER/FILLETS .02 [1.51] MACHINED SURFACES $\frac{125}{\text{INCH}} \sqrt{\text{mm}}$ mm SHOWN IN [BRACKETS]	DATE: 07-21-2004	
ECO DESCRIPTION SBI ON DESCRIPTION ZONE A1 CHANGED				APPROVED BY:	MATERIAL
<small>COPYRIGHT REGAL BELOIT AMERICA, INC. ALL RIGHTS RESERVED. PROPRIETARY AND CONFIDENTIAL INFORMATION - THIS DOCUMENT IS THE PROPERTY OF REGAL BELOIT AMERICA, INC. (OWNER) AND CONTAINS OWNER'S PROPRIETARY INFORMATION. ANY PERSON, CORPORATION OR OTHER FIRM RECEIVING IT IS DEEMED, BY RECEIVING IT, TO AGREE THAT IT, AND/OR ANY PART OF IT, SHALL NOT BE DISCLOSED TO ANY PERSON, CORPORATION OR OTHER ENTITY, DUPLICATED, AND/OR USED, EXCEPT AS EXPRESSLY APPROVED IN WRITING IN ADVANCE BY OWNER. THIS DOCUMENT SHALL BE RETURNED TO OWNER UPON REQUEST. IT MAY BE SUBJECT TO CERTAIN RESTRICTIONS UNDER APPLICABLE EXPORT CONTROL LAWS AND REGULATIONS.</small>				DATE:	SIZE DWG NO C 18850901
				PROCESS/FINISH	SHEET 1
				THIRD ANGLE PROJECTION	

4

3

2

1