

GENERAL INFORMATION:

SHAFT RUNOUT: .001 [.03] T.I.R. PER INCH LENGTH OF EXTENSION

END PLAY: .010 [.25] TO .063[1.60]

BEARINGS: SLEEVE

MOUNTING POSITION: ALL ANGLE

ELECTRICAL DATA:

OVERLOAD PROTECTOR: AUTOMATIC RESET (T.I. 7AM 304)

LINE LEADS: NO. 18 GA., .06 [1.5] THK. XLP 125°C INSUL.

REVERSING LEADS: NO. 18 GA., .03 [.8] THK. XLP 125°C INSUL.

GROUND LEAD: NO. 18 GA., .03 [.8] THK. (GREEN) INSUL.

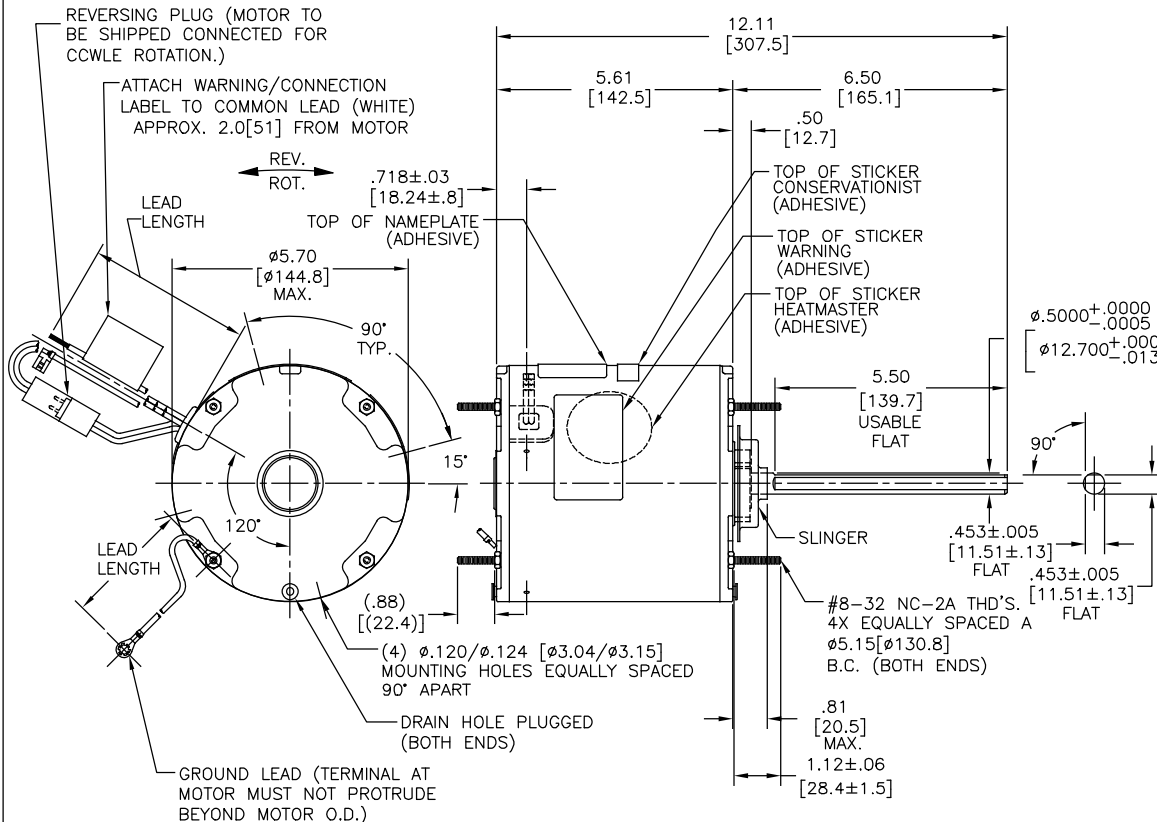

NAMEPLATE DATA:

MODEL NO.: F48X89A01
 CUST. P/N: FSE1058SF
 HP: 1/2
 ROT.: REVERSIBLE
 RPM: 825
 TYPE: UF
 FRAME: 48Y
 VOLTS: 208-230
 PH: 1
 AMPS: 2.5
 HZ: 60
 INS.: F
 AMB.: 70°C
 DUTY: AIR OVER
 CAP.: 10 MFD/370 V
 ENCL: ENCLOSED
 UL LOGO
 CSA LOGO
 THERMALLY PROTECTED

EXTERNAL CONNECTION DIAGRAM

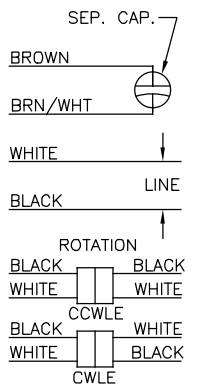

PERFORMANCE CURVE NO.	TORQUE @ 825 RPM (25°C)	APPROVED SAMPLE	UL COMPONENT		CSA	
			FILE #	CCN #	FILE #	CLASS #
C32580	50.8 OZ. FT.	0601197A	E46412	PRGY2	LR43341	4211-01

COLOR	LENGTH	TERMINAL OR STRIP LENGTH
GREEN (GROUND)	12.0/13.0 [305/330]	#10 EYELET
BLACK/WHITE	3.0/5.0 [76/127]	REVERSING PLUG
BROWN	48.0/51.0 [1219/1295]	.25 [6.4] FLAG
BROWN/WHITE	48.0/51.0 [1219/1295]	.25 [6.4] FLAG
WHITE	48.0/51.0 [1219/1295]	.50 [12.7] SKIN
BLACK	48.0/51.0 [1219/1295]	.50 [12.7] SKIN

REGAL-BELOIT CORPORATION (RBC) PROVIDES TECHNICAL ASSISTANCE TO OUR CUSTOMERS IN SEVERAL AREAS. SINCE RBC DOES NOT RECEIVE ALL DATA CONCERNING THE USE AND APPLICATION OF THE MOTOR, THE SUITABILITY OF THE MOTOR FOR THE APPLICATION MUST BE DETERMINED BY THE CUSTOMER.

DIMENSIONS WITHOUT TOLERANCES ARE FOR REFERENCE ONLY.

MAIN FRAME - OLE	ENCLOSED
END FRAME - OLE	ENCLOSED
MAIN FRAME - LE	ENCLOSED
END FRAME - LE	ENCLOSED

NOTES:

- ATTACH INSTRUCTION SHEET 681572-003 ONTO SHAFT APPROX. 1.0[25] FROM WATER SLINGER (OR 69P9-3 ONLY USED IN MEXICO)
- (4) SCREWS 615982-001 & (4) EXTRA HEX NUTS 7555A19H01 TO BE PUT IN A POLYBAG.

DRAWING REVISION		REVISION BY		DATE	
E	ECO-0166568	CELIN ZHAO	KEYUN QONG	05-23-2019	05-23-2019
SEE ECO					

REGAL-BELOIT CORPORATION (RBC) PROVIDES TECHNICAL ASSISTANCE TO OUR CUSTOMERS IN SEVERAL AREAS. SINCE RBC DOES NOT RECEIVE ALL DATA CONCERNING THE USE AND APPLICATION OF THE MOTOR, THE SUITABILITY OF THE MOTOR FOR THE APPLICATION MUST BE DETERMINED BY THE CUSTOMER.

DRAWN BY: A. NAJERA		DATE: 05-02-2011	
APPROVED BY: J. RUPERT		DATE: 05-02-2018	
PROCESS/FINISH: -		MATERIAL: -	
THIRD ANGLE PROJECTION		SIZE DWG NO: C	
REGAL-BELOIT CORPORATION (RBC)		DESCRIPTION: MODEL-RFHP-48FR OUTLINE	
FSE1058SF		SHEET 1	