

GENERAL INFORMATION:

SHAFT RUNOUT: .001[.03] T.I.R. PER INCH LENGTH OF EXTENSION

BEARINGS: BALL

MOUNTING POSITION: HORIZONTAL

ELECTRICAL DATA:

OVERLOAD PROTECTOR: AUTOMATIC RESET (T.I. 7AM 036)

LINE LEADS: NO. 18 GA., .03[.8] THK. XLP 125°C INSUL.

REVERSING PLUGS: NO. 18 GA., .03[.8] THK. XLP 125°C INSUL.

GROUND LEAD: NO. 18 GA., .03[.8] THK. (GREEN) INSUL.

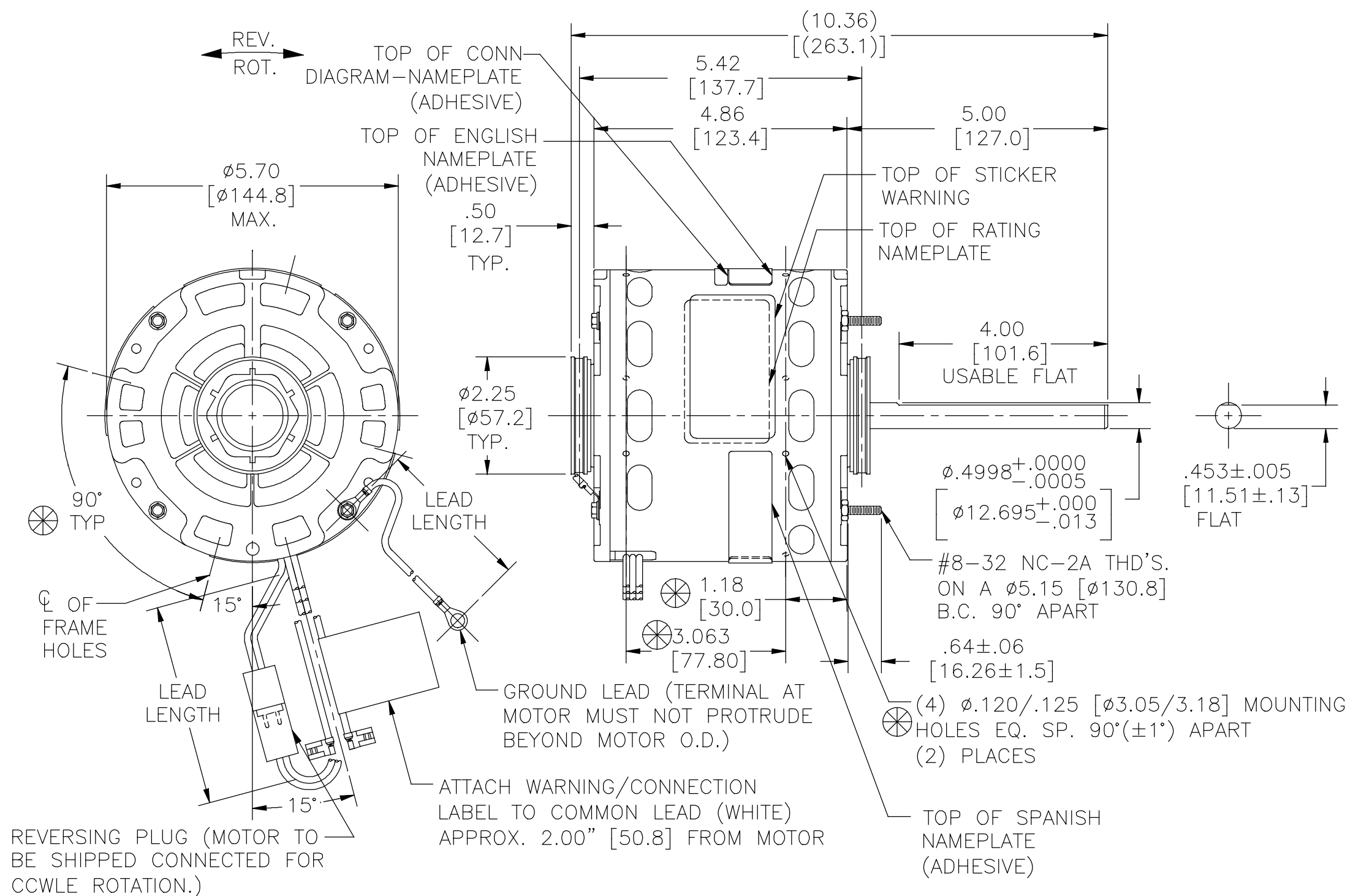

NOTE:

1. DENOTES ⊗ CRITICAL CHARACTERISTICS
2. (4) SPLIT RING ADAPTOR 615035, (8) SCREWS 615982-001 TO BE PUT IN A POLYBAG & BE PACKED WITH EACH MOTOR

REGAL-BELOIT CORPORATION (RBC) PROVIDES TECHNICAL ASSISTANCE TO OUR CUSTOMERS IN SEVERAL AREAS. SINCE RBC DOES NOT RECEIVE ALL DATA CONCERNING THE USE AND APPLICATION OF THE MOTOR, THE SUITABILITY OF THE MOTOR FOR THE APPLICATION MUST BE DETERMINED BY THE CUSTOMER.

DIMENSIONS WITHOUT TOLERANCES ARE FOR REFERENCE ONLY.

MAIN FRAME - OLE	OPEN
END FRAME - OLE	OPEN
MAIN FRAME - LE	OPEN
END FRAME - LE	OPEN

CUSTOMER	DISTRIBUTION SERVICE
----------	----------------------

COLOR	LENGTH	TERMINAL OR STRIP LENGTH
GREEN (GROUND)	9.0/11.0 [229/279]	.25[6.4] RING
BLACK/WHITE	3.0/5.0 [76/127]	REVERSING PLUG
BROWN	36.5/39.5 [927/1003]	.25[6.4] FLAG
BROWN/WHITE	36.5/39.5 [927/1003]	.25[6.4] FLAG
RED	36.5/39.5 [927/1003]	.25[6.4] FLAG
YELLOW	36.5/39.5 [927/1003]	.25[6.4] FLAG
BLUE	36.5/39.5 [927/1003]	.25[6.4] FLAG
BLACK	36.5/39.5 [927/1003]	.25[6.4] FLAG
WHITE	36.5/39.5 [927/1003]	.25[6.4] FLAG

NAMEPLATE DATA:	EXTERNAL CONNECTION DIAGRAM
MODEL NO.: F48AE82A01 CUST. P/N: EM3466 HP: 3/4 MAX. ROT.: REVERSIBLE RPM: 1075/4 SPD. TYPE: UF FRAME: 48Y VOLTS: 115 PH: 1 AMPS: 9.1 MAX. HZ: 60 INS.: B AMB.: 40° C DUTY: AIR OVER CAP.: 10 MFD/370 V ENCL: OPEN UL LOGO CSA LOGO THERMALLY PROTECTED	<p>BROWN SEP. CAP</p> <p>BRN/WHT</p> <p>WHITE</p> <p>BLACK HI</p> <p>BLUE MH</p> <p>YELLOW ML</p> <p>RED LO</p> <p>ROTATION</p> <p>BLACK WHITE</p> <p>WHITE CCWLE</p> <p>BLACK WHITE</p> <p>WHITE CWLE</p>

PERFORMANCE CURVE NO.	TORQUE @1075 RPM (25°C)	APPROVED SAMPLE	UL COMPONENT FILE #	CSA FILE #
C32039	58.1 OZ. FT.	0143719A	E46412 PRGY2	LR43341 4211-01

DRAWING REVISION C	REVISION BY CADDIE.ZHOU	DATE 05-17-2019
ECO-0165198	APPROVED BY KEYUN.GONG	DATE 05-17-2019
ECO DESCRIPTION @ZONE C2 ADD SPANISH NAMEPLATE		

DRAWN BY: D.ZHANG	DATE: 10-31-2011	Regal Beloit America, Inc.
APPROVED BY: HONG.ZHU	DATE: 10-31-2011	
THIRD ANGLE PROJECTION	SIZE DWG NO C	DESCRIPTION MODEL-RFHP-48FR OUTLINE
		MATERIAL - PROCESS/FINISH -
		SHEET 1

COPYRIGHT REGAL-BELOIT AMERICA, INC. ALL RIGHTS RESERVED. PROPRIETARY AND CONFIDENTIAL INFORMATION - THIS DOCUMENT IS THE PROPERTY OF REGAL-BELOIT AMERICA, INC. (OWNER) AND CONTAINS OWNER'S PROPRIETARY INFORMATION. ANY PERSON, CORPORATION OR OTHER FIRM RECEIVING IT IS DEEMED, BY RECEIVING IT, TO AGREE THAT IT, AND/OR ANY PART OF IT, SHALL NOT BE DISCLOSED TO ANY PERSON, CORPORATION OR OTHER ENTITY, DUPLICATED, AND/OR USED, EXCEPT AS EXPRESSLY APPROVED IN WRITING IN ADVANCE BY OWNER. THIS DOCUMENT SHALL BE RETURNED TO OWNER UPON REQUEST. IT MAY BE SUBJECT TO CERTAIN RESTRICTIONS UNDER APPLICABLE EXPORT CONTROL LAWS AND REGULATIONS.