

REV	ECO	REV BY	DATE	APPD	DATE
B	ECO-0025365	T.HUANG	04-17-2012	B.C.SHEN	04-17-2012

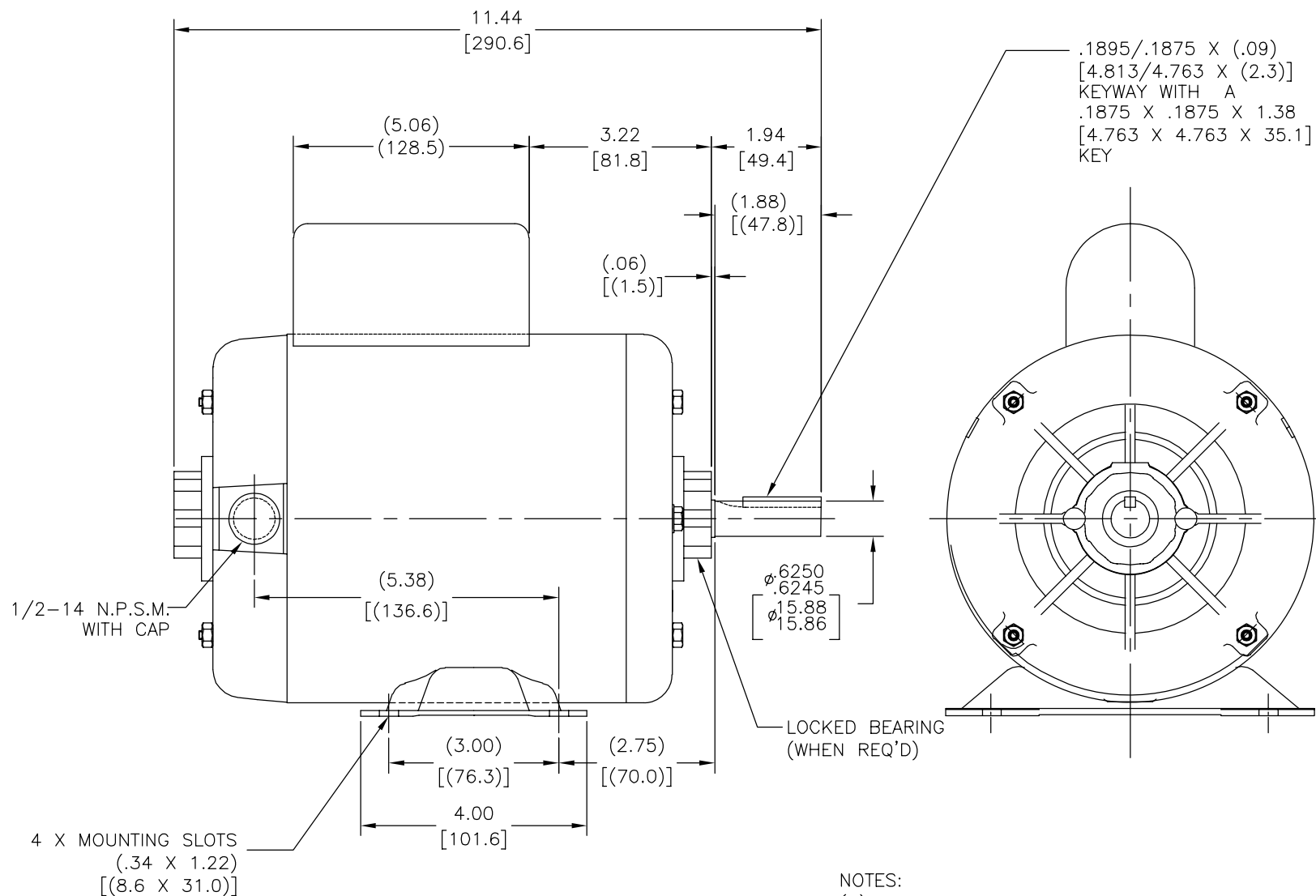
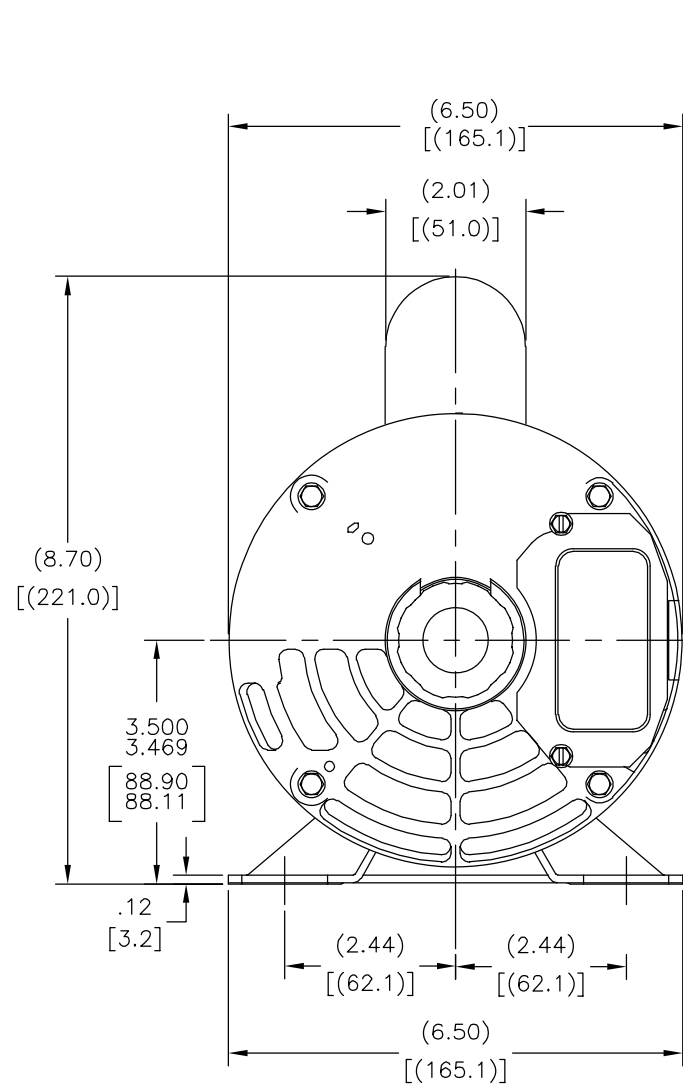

NOTES:
 (1) ALL DIMENSIONS SHOWN IN PARENTHESIS ARE REFERENCE DIMENSIONS. ALL OTHER DIMENSIONS ARE TOLERANCED PER THE FOLLOWING CHART UNLESS OTHERWISE SPECIFIED.
 "C" DIMENSION = +/- .055[1.40]
 SHAFT EXTENSION = +/- .034[.86]
 LEAD LENGTHS = +/- 1.00[25.4]
 EXTENDED THRU-BOLTS = +/- .050[1.27]

GEOMETRIC CHARACTERISTICS & SYMBOLS

- ▭ FLATNESS
- STRAIGHTNESS
- ∠ ANGULARITY
- ⊥ PERPENDICULARITY (SQUARENESS)
- // PARALLELISM
- ROUNDNESS (CIRCULARITY)
- ⊘ CYLINDRICITY
- △ PROFILE OF ANY SURFACE
- ∩ PROFILE OF ANY LINE
- ↗ RUNOUT
- ⊕ TRUE POSITION
- ◎ CONCENTRICITY
- ≡ SYMMETRY

ASME Y14.5M 1994

UNLESS OTHERWISE SPECIFIED DIM. TOLERANCES ARE AS FOLLOWS:

INCH	X	XX	XXX	XXXX
	±.1	±.02	±.005	±.0005
mm	±0.5	±0.13	±0.013	

ANG. ±.50 DEG
 REMOVE BURRS & BREAK SHARP EDGES:
 INCH .003-.015 mm 0.1-0.4
 CORNER FILLETS TO:
 INCH .020 mm 0.5
 MACHINE SURFACES:
 INCH 125 mm 3.2

METRIC DIMS. SHOWN IN [BRACKETS]

DR BY:	BS	02-01-2009
APPD:	LX	02-01-2009
THIRD ANGLE PROJECTION		EDS DATE 11-11-2011 FORMAT REV G
CONFIDENTIAL: THIS DRAWING AND ITS INFORMATION ARE THE EXCLUSIVE AND CONFIDENTIAL PROPERTY OF REGAL-BELOIT CORPORATION AND ARE NOT TO BE DISCLOSED, DUPLICATED, DISTRIBUTED OR OTHERWISE USED WITHOUT THE WRITTEN CONSENT OF REGAL-BELOIT CORPORATION. -ALL RIGHTS RESERVED.		

DESCRIPTION OUTLINE	
SIZE C	DWG NO B221
SCALE NONE	SHEET 1

4

3

2

1

REVISION:	ECO	REVISADO POR:	FECHA:	APROBADO POR:	FECHA:
B	ECO-0025365	T.HUANG	04-17-2012	B.C.SHEN	04-17-2012

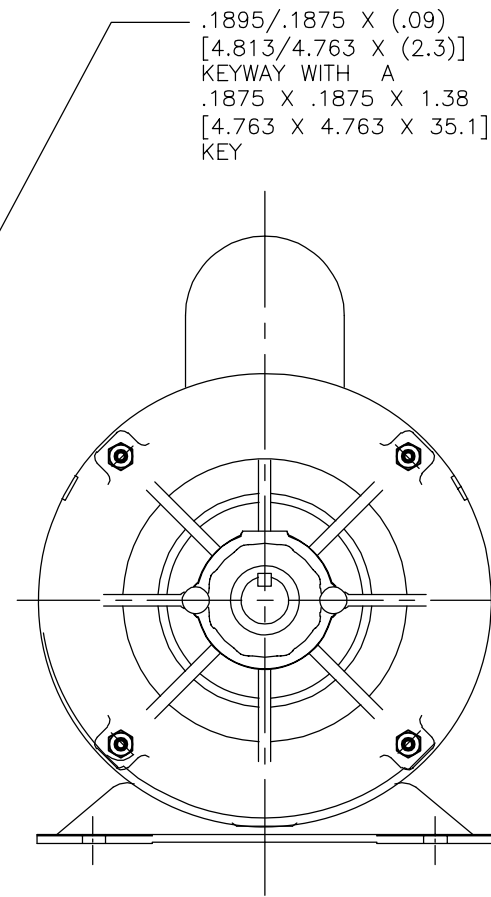
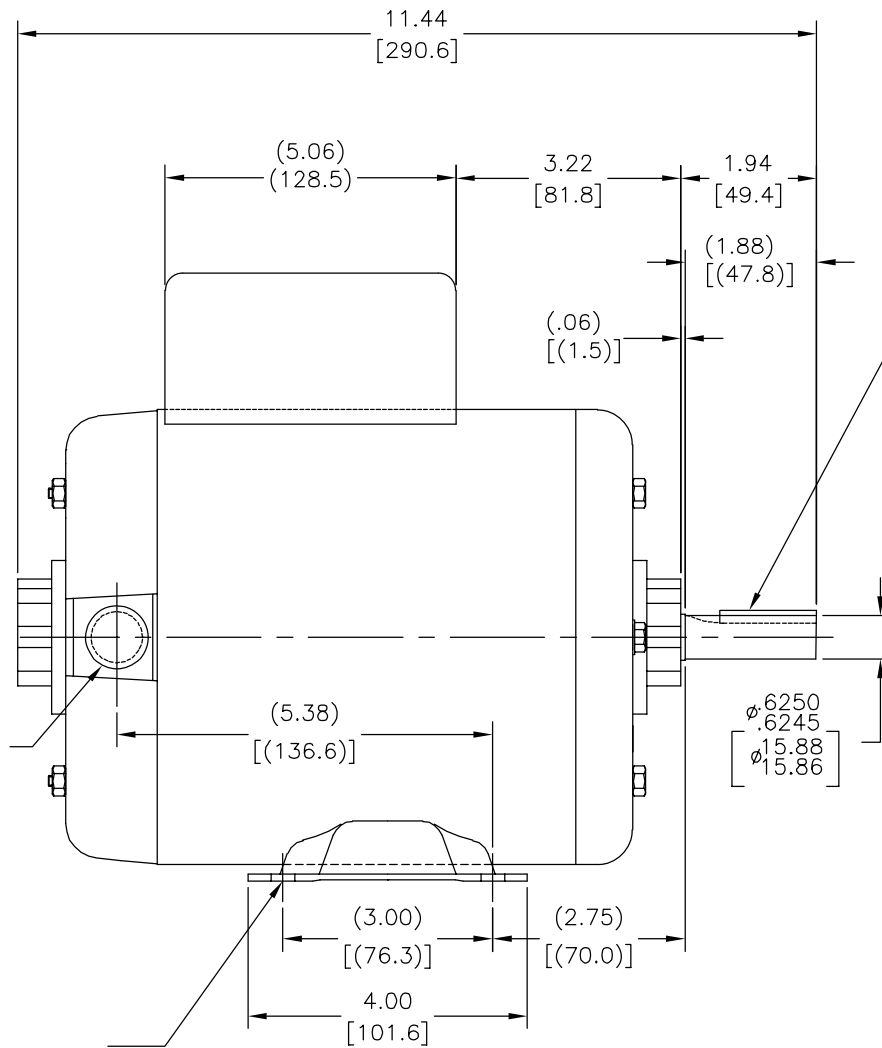
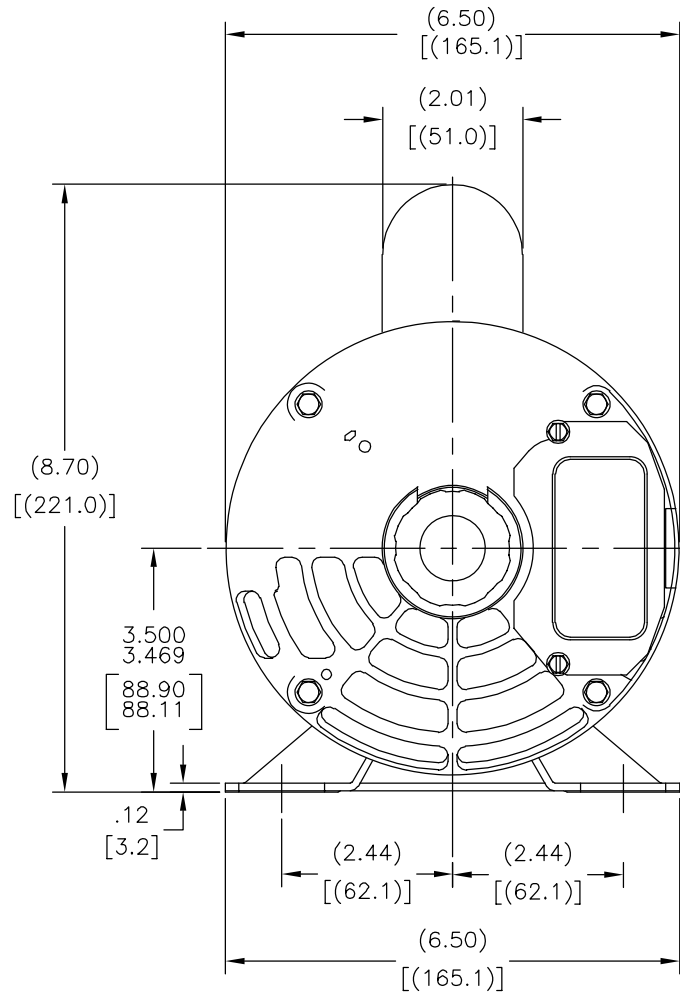

CARACTERISTICAS DE GEOMETRIA Y SIMBOLOS

- ▧ PLANICIDAD
- RECTITUD
- ∠ ANGULARIDAD
- ⊥ PERPENDICULARIDAD (A ESCUADRA)
- // PARALELISMO
- REDONDEZ (CIRCULARIDAD)
- ∅ CILINDRICIDAD
- △ PERFIL DE CUALQUIER SUPERFICIE
- ∧ PERFIL DE CUALQUIER LINEA
- ∧ VARIACION
- ⊕ POSICION REAL
- ◎ CONCENTRICIDAD
- = SIMETRIA

ASME Y14.5M 1994

A MENOS QUE SE ESPECIFIQUE DE OTRA MANERA, LAS TOLERANCIAS DE LAS DIMS; SON LAS SIGUIENTES:

	X	XX	XXX	XXXX
PULG	±.1	±.02	±.005	±.0005
mm	±0.5	±0.13	±0.013	
ANG.	±.50	GRADOS		

ELIMINAR REBABAS Y ORILLAS FILOSAS DEL BORDE.

PULG .003-.015 mm 0.1-0.4
 FILETEAR ESQUINA: PULG .020 mm 0.5
 MAQUINAR SUPERFICIES
 PULG 125 mm .32

DIMS METRICAS MOSTRADAS [PARENTESIS]

DIBUJADO POR:	BS	02-01-2009
APROBADO POR:	LX	02-01-2009
TERCER ANGULO DE PROYECCION	⊕	FECHA EDS: 11-11-2011 REV. FORMATO: G
CONFIDENCIAL: ESTE DIBUJO Y SU INFORMACION SON PROPIEDAD DE USO EXCLUSIVO Y CONFIDENCIAL DE REGAL-BELOIT CORPORATION. Y NO DEBERAN SER REVELADOS, DUPLICADOS, DISTRIBUIDOS O USARSE DE OTRA MANERA SIN EL CONSENTIMIENTO ESCRITO DE REGAL-BELOIT CORPORATION. -TODOS LOS DERECHOS RESERVADOS.		

DESCRIPCION: OUTLINE	
TAMAÑO: C	NUMERO DE DIBUJO: B221
ESCALA: NONE	HOJA: 1

4

3

2

1

版本	ECO	编制	日期	批准	日期
B	ECO-0025365	T.HUANG	04-17-2012	B.C.SHEN	04-17-2012

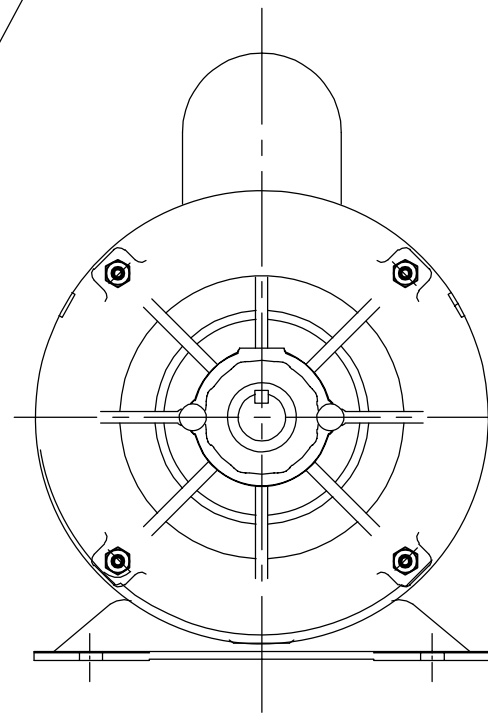
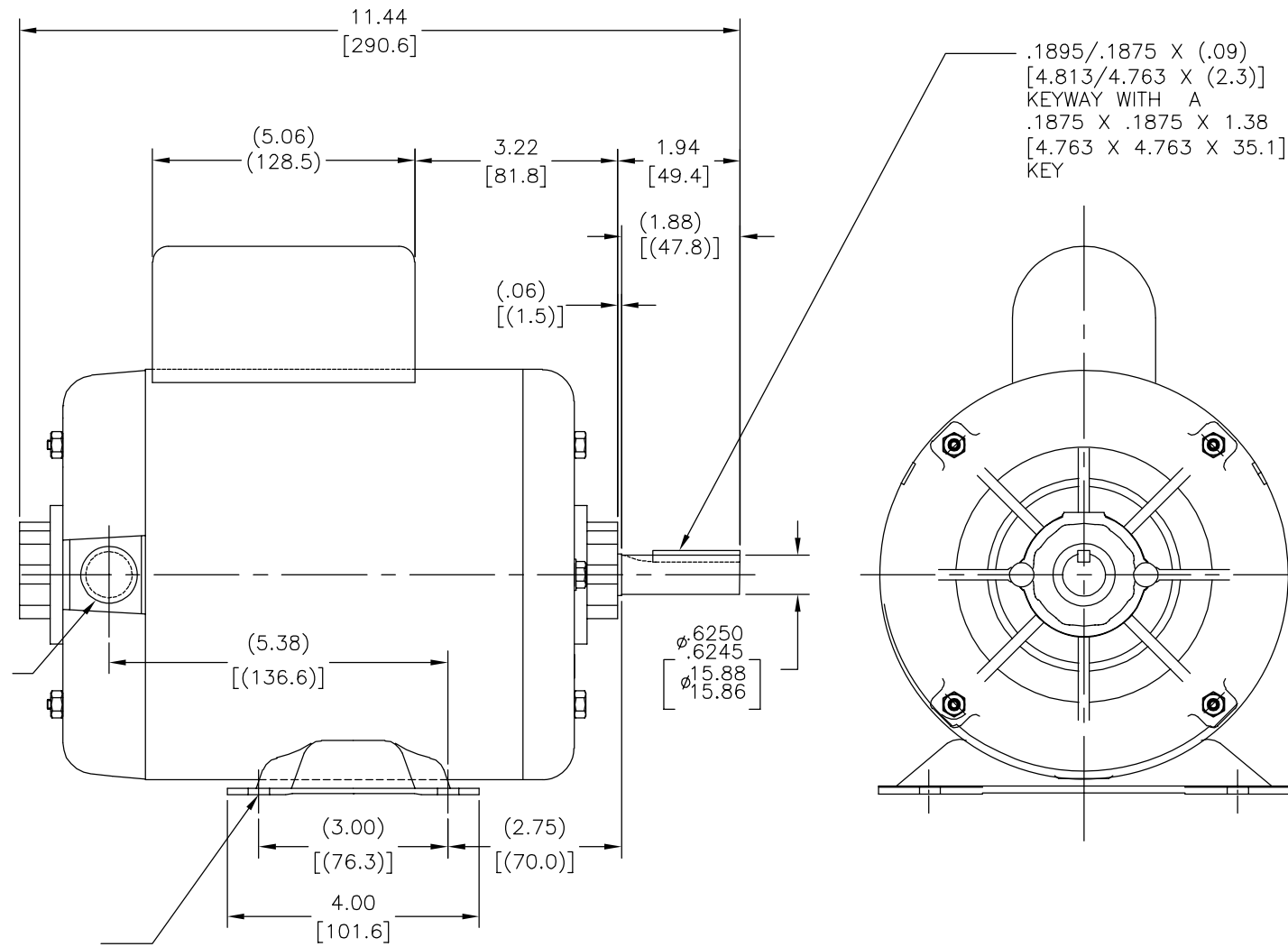
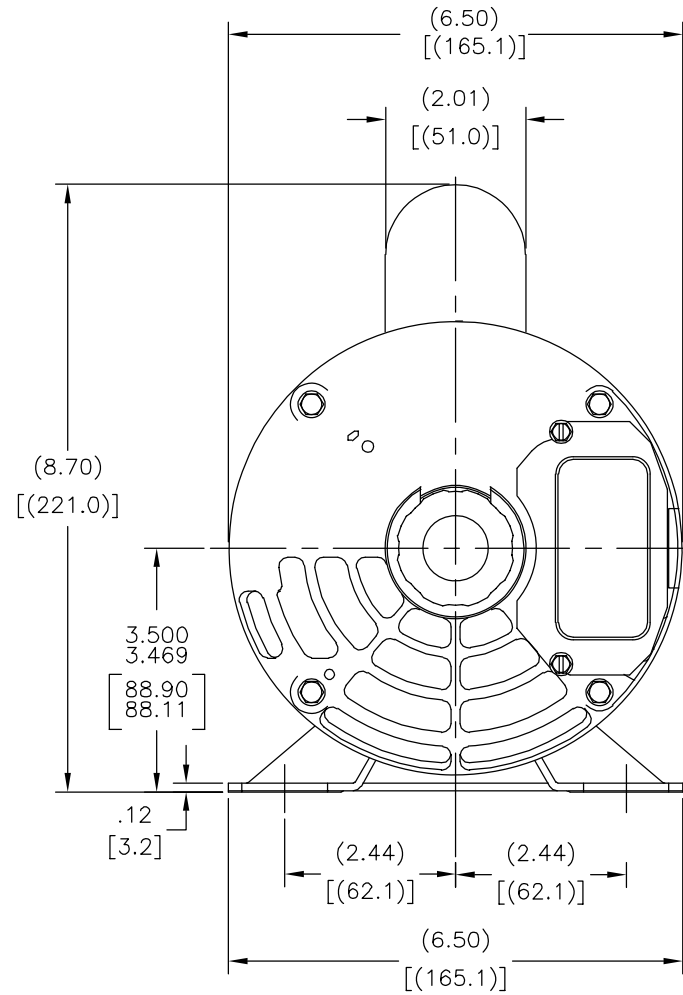

形位公差	除另有注明
□ 平面度	尺寸公差如下:
— 直线度	英寸 X XX XXX XXXX
∠ 倾斜度	英寸 ±.1 ±.02 ±.005 ±.0005
⊥ 垂直度	毫米 ±0.5 ±0.13 ±0.013
// 平行度	角度 ±.50 度
○ 圆度	清理毛刺和尖棱
⊘ 圆柱度	英寸 .003-.015 毫米 0.1-0.4
△ 面轮廓度	内圆角
∩ 线轮廓度	英寸 .020 毫米 0.5
⤴ 圆跳动	表面粗糙度
⊕ 位置度	英制 125 米制 3.2
◎ 同轴度	米制尺寸显示在 []
≡ 对称度	

ASME Y14.5M 1994

除另有注明	尺寸公差如下:
英寸 X XX XXX XXXX	
英寸 ±.1 ±.02 ±.005 ±.0005	
毫米 ±0.5 ±0.13 ±0.013	
角度 ±.50 度	
清理毛刺和尖棱	
英寸 .003-.015 毫米 0.1-0.4	
内圆角	
英寸 .020 毫米 0.5	
表面粗糙度	
英制 125 米制 3.2	
米制尺寸显示在 []	

绘图:	BS	02-01-2009
批准:	LX	02-01-2009
第三角投影		图纸格式发布日期 11-11-2011 图纸格式版本 G
机密: 本图纸及相关信息所有权归REGAL-BELOIT CORPORATION 未经REGAL-BELOIT CORPORATION书面授权, 不得泄露、 复制、传播或作其他用途。一版权所有		

名称 OUTLINE	
图幅 C	图号 B221
比例 NONE	页号 1