

NO. A-23089

NO.	REVISIONS	DATE AND SIGNATURE
1	ADDED MODEL NUMBERS	11-9-94
2	LEAD WAS (2) #10 EYELETS	7-*6-98
3	CUST NAME CHANGED WAS MAGNETEK	6-07-02

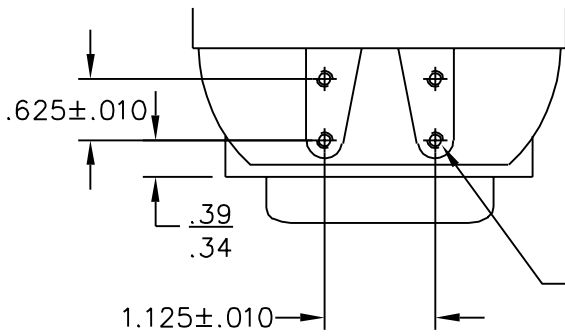

OUTLINE DIMENSIONS ON WHICH NO LIMIT IS SPECIFIED ARE NOMINAL AND NOT GUARANTEED AS TO TOLERANCE. ADDITIONAL INFORMATION ON TOLERANCE WILL BE FURNISHED ON SPECIFIC REQUEST.

"M" MOUNTING  
#8-36 N.F. 4 HOLES TAPPED THRU  
BOTH SIDES

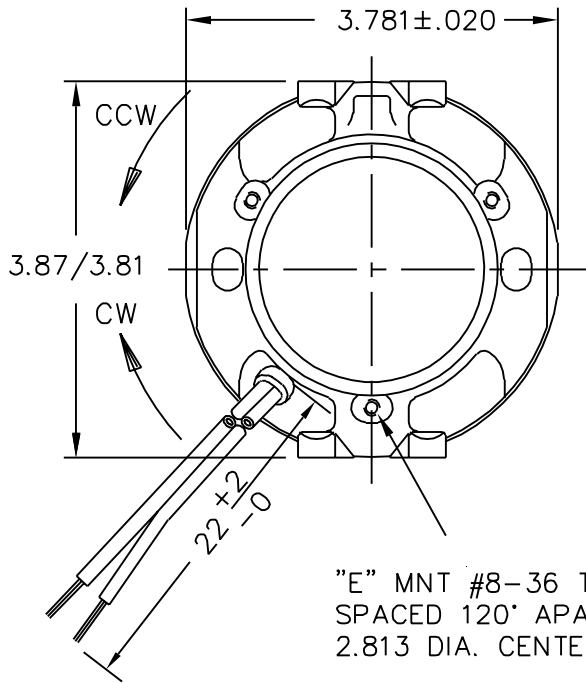

"E" MNT #8-36 TAPPED HOLES  
SPACED 120° APART ON A  
2.813 DIA. CENTER LINE.

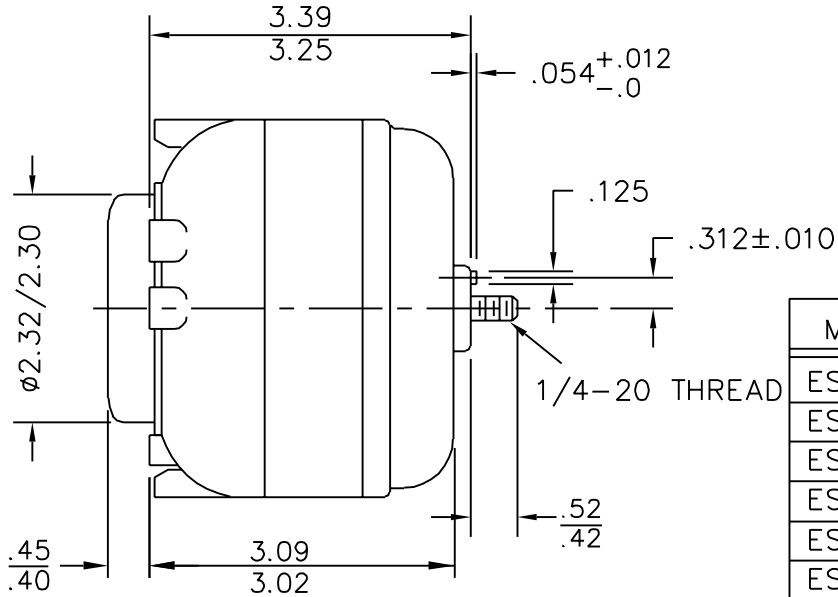

A.O. SMITH

MODEL	CUST NO.
ESP-L16EM1	= 246
ESP-L16EM2	= 248
ESP-L16EMR1	= 247
ESP-L16EMR2	= 249
ESP-L25EM1	= 250
ESP-L25EM2	= 252
ESP-L25EMR1	= 251
ESP-L25EMR2	= 253
ESP-L35EM1	= 254
ESP-L35EM2	= 256
ESP-L35EMR1	= 255
ESP-L35EMR2	= 257

R = CCW ROTATION

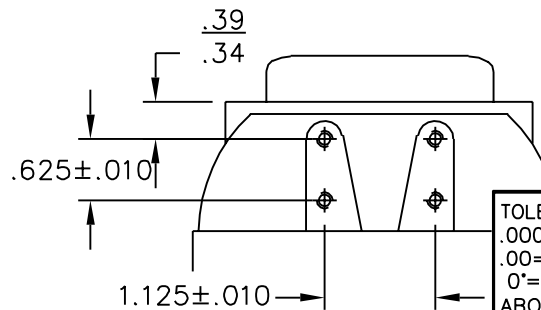

TOLERANCE  
.0000=±.0002 .000=±.005  
.00=±.010 FRACTION=±1/64  
0°=±30' 0'0°=±5' 0'0'0°=REF. ONLY  
ABOVE TOLERANCES APPLY UNLESS  
OTHERWISE SPECIFIED TOLERANCES  
ARE NOT ACCUMULATIVE.

<b>ELECTRIC MOTORS AND SPECIALTIES INC.</b>			
230V 60/50HZ CW GARRETT, INDIANA 46738			
FIRST MADE FOR ESP-L16EM2		A.O. SMITH	
DRAWN BY JIM NICTER		DATE 4-11-94	
TITLE MOTOR OUTLINE		MATERIAL CUST NO. 248	
SCALE 1/2 SIZE		APPROVED BY DATE	
		NO. A-23089	