

# RPM-AC FINNED FRAME VARIABLE SPEED ALTERNATING CURRENT MOTOR FL2570Z

ENCLOSURE: TOTALLY ENCLOSED  
 MOUNTING: FOOT  
 DRIVE METHOD: COUPLED OR BELTED

COOLING: BLOWER COOLED  
 ACCESSORIES: ENCODER

617573-342

2.06  
MIN.  
AIR  
SPACE

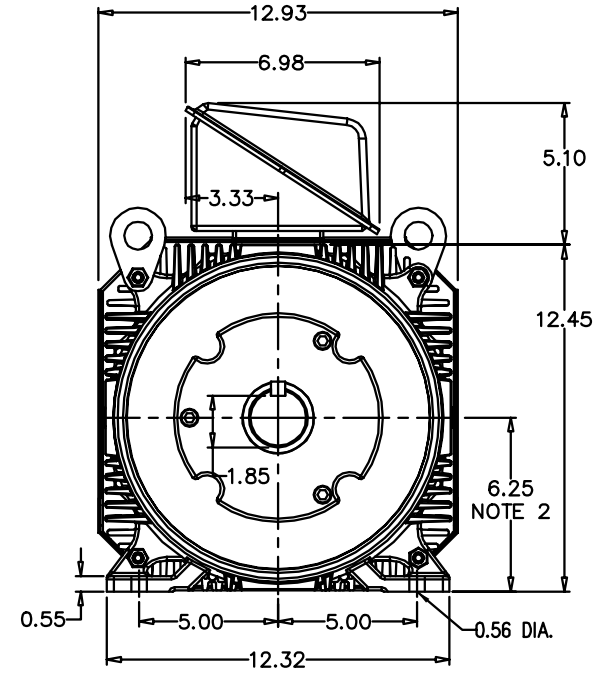
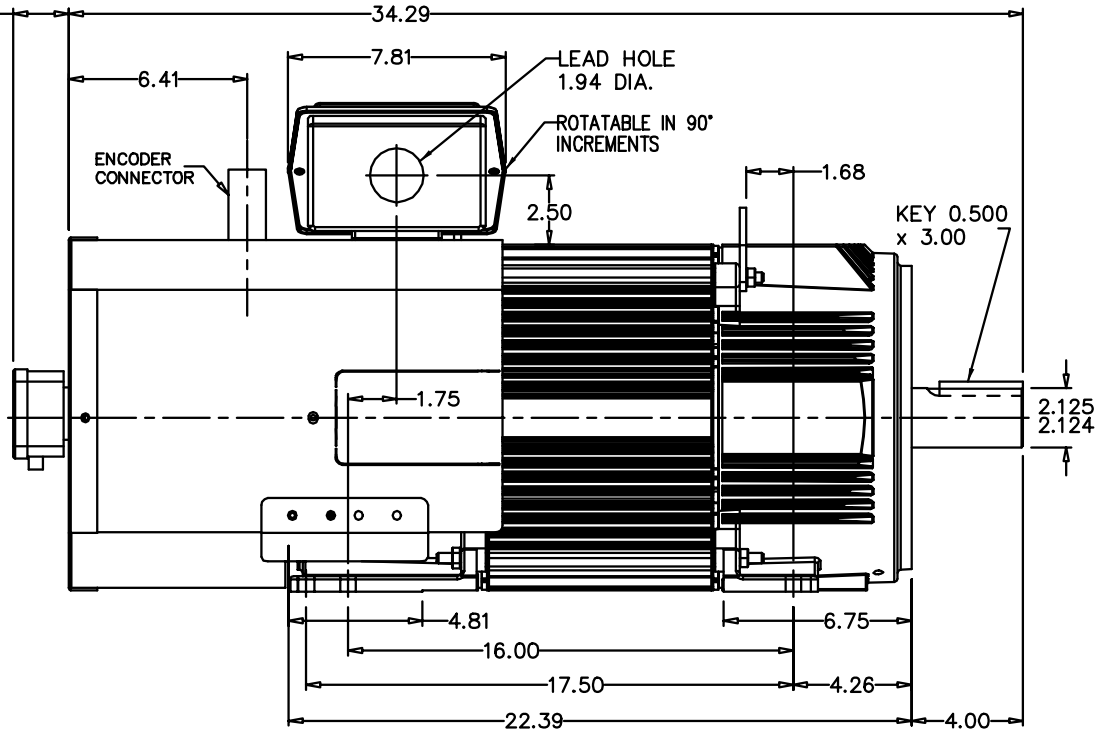

NOTE 1: C-FACE & TACHOMETER MOUNTING  
 1/2-13 TAP, 1.00 DEEP, ON A 7.25 DIA. BOLT CIRCLE  
 FACE RUNOUT AND ECCENTRICITY 0.004 MAX. T.I.R.

NOTE 2: SHAFT HEIGHT WILL NOT BE EXCEEDED  
 SHIMS UP TO 0.03 INCHES IN THICKNESS ARE USUALLY  
 REQUIRED FOR COUPLED OR GREARED MACHINES

TERMINAL BOX MAY BE LOCATED F1 OR F2 IF SPECIFIED  
 121 AMP STEEL TERMINAL BOX SHOWN  
 REFER TO 616779-50 FOR SPECIFIED TERMINAL BOX DIMENSIONS

MOTOR WEIGHT: 475 LBS. (MAY VARY 15%)  
 DIMENSIONS ARE IN INCHES SCALE: 1.00

CUSTOMER IS RESPONSIBLE FOR DETERMINING THAT THIS PRODUCT WILL PERFORM SUITABLY IN THE INTENDED APPLICATION.

REV. DESC: CHANGE TO GENERIC CONNECTOR AND ENCODER		
REV. LTR: B	VERSION: 02	TDR: 00000984829
FILE: \RGG\00025\788	REVISED: 01:22:34 06/27/2016	BY: RGGWT
MTL: -		

**BALDOR**

DIM SHT,RPMAC,TEBC,FL2570Z,ENCODER

SH 1 of 1

617573-342