

RPM-AC FINNED FRAME ALTERNATING CURRENT MOTOR NEMA HL326T

ENCLOSURE: TOTALLY ENCLOSED

MOUNTING: FOOT

DRIVE METHOD: COUPLED

COOLING: FAN COOLED

619699-001

D

C

B

A

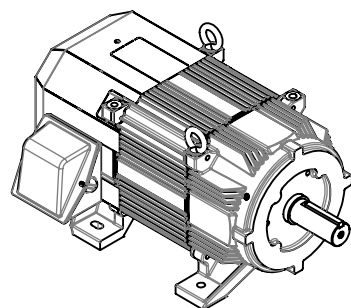
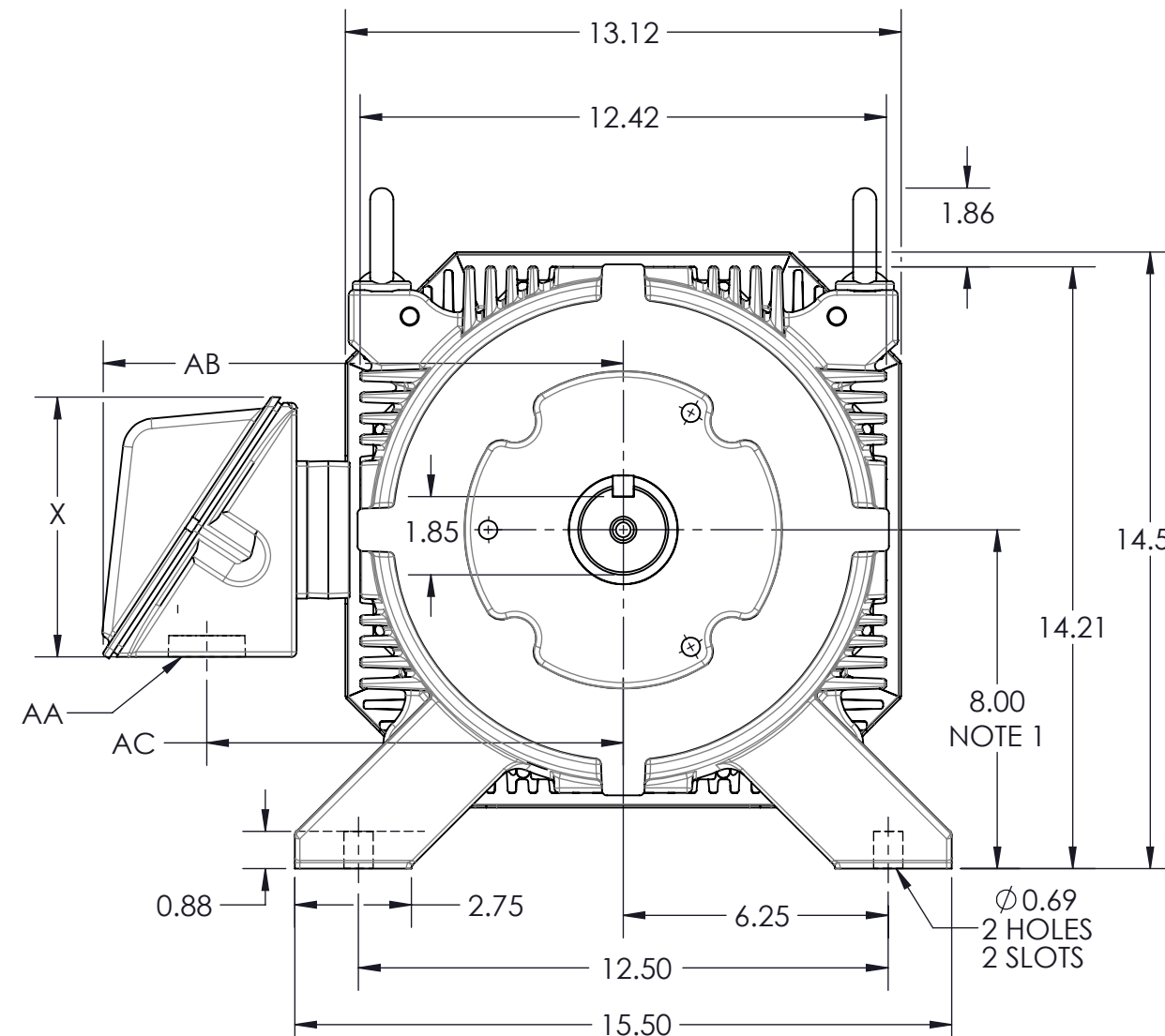
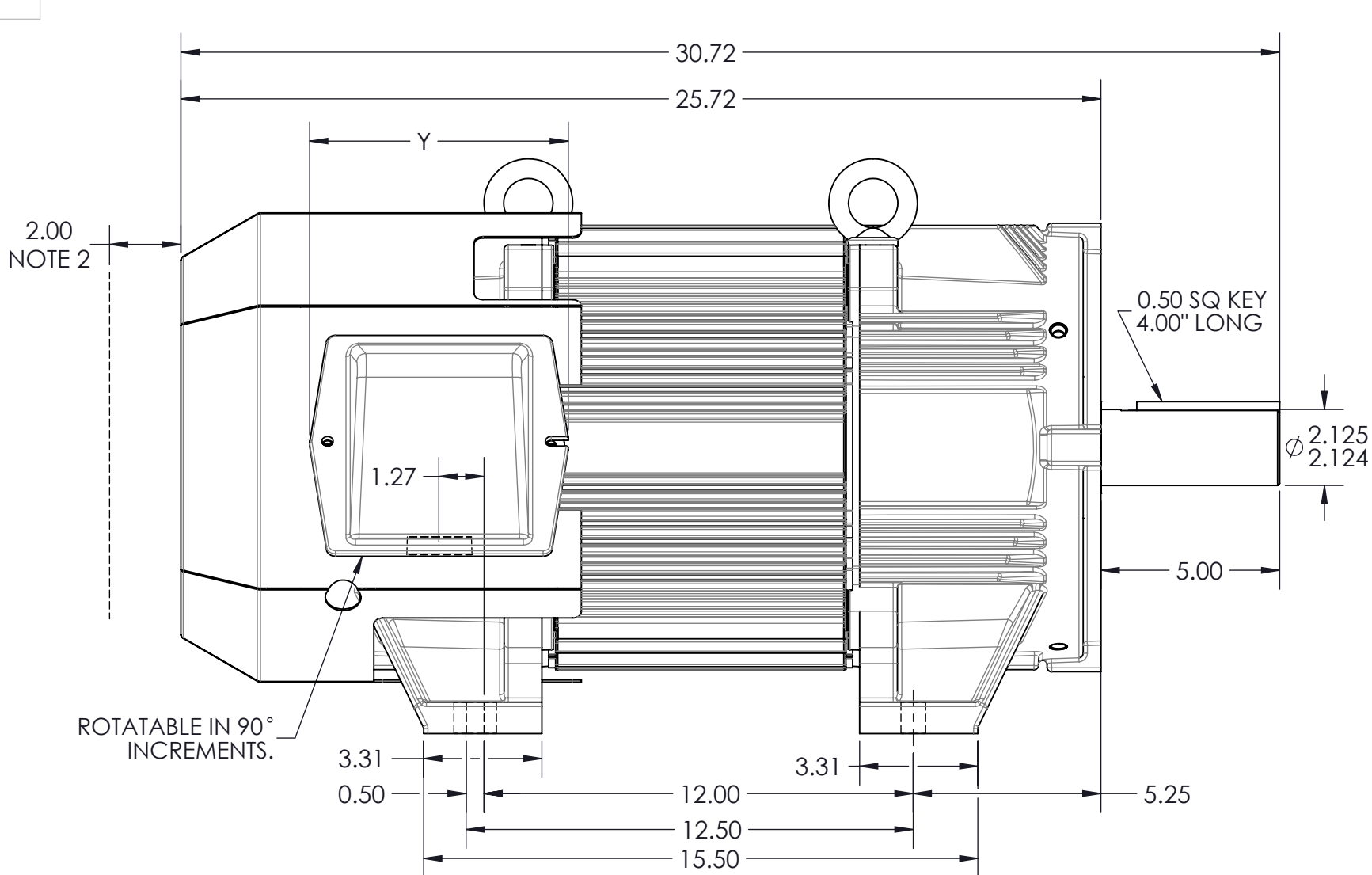

DIMENSIONS ARE IN INCHES

MOTOR WEIGHT: 500 LBS. (MAY VARY 15% FOR NON-STANDARD RATINGS AND / OR ACCESSORIES.)

NOTES:

1. SHAFT HEIGHT WILL NOT BE EXCEEDED. SHIMS UP TO 0.06 INCHES IN THICKNESS ARE USUALLY REQUIRED FOR COUPLED OR GEARED MACHINES.
2. WALLS OR OBSTRUCTIONS MUST NOT ENCROACH ON AIR INLET SPACE.

TERMINAL BOX MAY BE LOCATED F1, F2, OR F3 IF SPECIFIED.
TERMINAL BOX MAY BE LOCATED DRIVE END OR OPPOSITE DRIVE END IF SPECIFIED.
REFER TO DATA TRANSMITTAL OR PARTS LIST FOR TERMINAL BOX PART NUMBER

TERMINAL BOX	X	Y	AA	AB	AC	MAX AMPS	REMARKS
075452-000B	5.44	6.34	1.75	11.33	9.34	61	STEEL
075454-001AJ	7.00	7.69	1.94	12.46	9.72	121	STEEL
075460-062B	6.00	7.25	1.5 TAP	12.27	9.83	110	CAST IRON (AS SHOWN)
706320-013A	9.50	10.50	4.0 TAP	15.15	10.97	210	CAST IRON
706310-056A	7.72	7.75	Pg36 &Pg16	11.35	9.25	100	TERMINAL STRIP
706310-056B	8.98	9.00	Pg36 &Pg16	11.91	9.50	160	TERMINAL STRIP

CUSTOMER IS RESPONSIBLE FOR DETERMINING THAT BALDOR'S PRODUCT WILL PERFORM SUITABLY IN THE INTENDED APPLICATION

REV. DESC: UPDATE FAN CVR,CBOX AND SPACER,UPDATE NAME TO HL			
REV: B	VERSION: 02	REVISED: 03:52:20 05/24/2016	TDR: 000000979577
MODEL NO. 619699-001		REF: -	
BY: USMAWOO		B	

BALDOR

DIM SHEET,NEMA HL326T,RPM-AC FL2570,TEFC

619699-001

8

7

6

5

4

3

2

1