

8 7 6 5 4 3 2 1

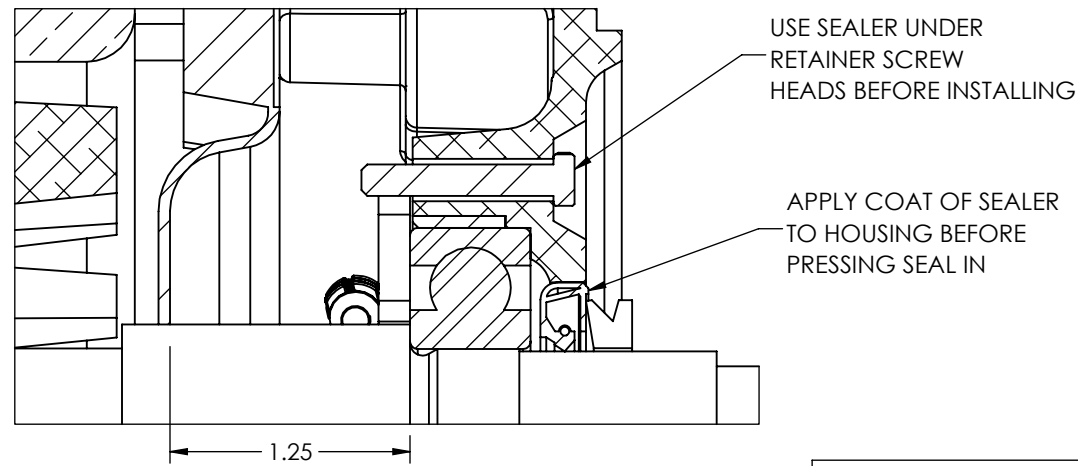
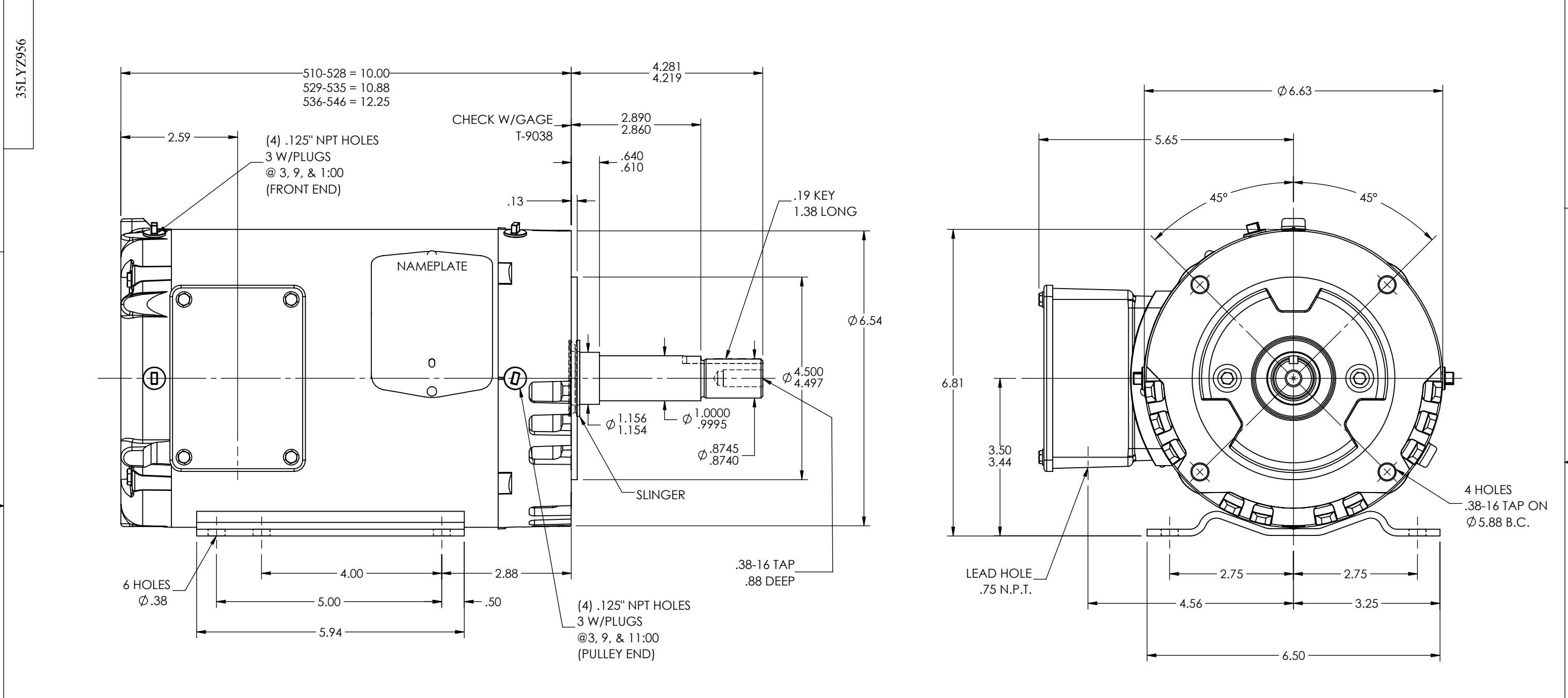

PULLEY END DETAIL

CUSTOMER IS RESPONSIBLE FOR DETERMINING THAT THE PRODUCT WILL PERFORM SUITABLY IN THE INTENDED APPLICATION

REV. DESC: LOADING OF SWD DWG FOR 2D TO 3D CONVERSION PKG 15			
REV: C	VERSION: 03	REVISED: 09:34:03 01/22/2019	TDR: 000001096905
MODEL NO. 35LYZ956		REF: -	
BY: ENALEM0		<b>B</b>	

**BALDOR - RELIANCE®**

STD HORZ 143-5JM TENV 35M WD W/.75 N.P.T. LH  
SH 1 of 1

35LYZ956

35LYZ956

8 7 6 5 4 3 2 1