

DUTY MASTER ALTERNATING CURRENT MOTORS

SQUIRREL-CAGE INDUCTION

ENCLOSURE: TOTALLY ENCLOSED
MOUNTING: FOOT

COOLING: FAN COOLED

FRAMES 250T THRU 440T

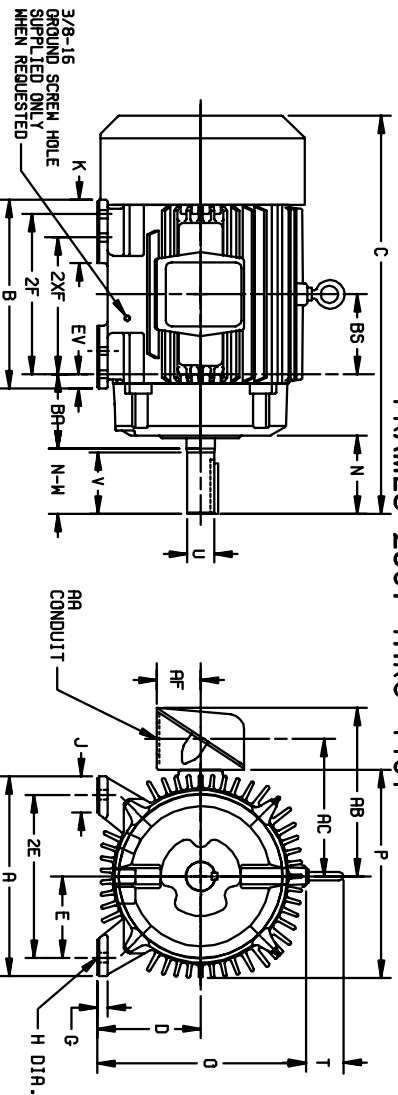

DIMENSIONS ARE IN INCHES; SEE SHEET 2 FOR DIMENSIONS IN MILLIMETERS

FRAME SIZE	DIMENSIONS ARE IN INCHES; SEE SHEET 2 FOR DIMENSIONS IN MILLIMETERS											STEEL TERMINAL BOX						WEIGHT (LBS.) (5)
	A	D(2)	E	G	H	J	K	O	P	T	AA	AB	AC	AF	BA	EV		
254T-256T	12.50	6.25	5.00	.75	.56	2.50	---	13.25	13.25	2.44	1-1/4	10.75	8.75	2.50	4.25	1.00		
284T-286TS	13.75	7.00	5.50	.75	.56	2.50	---	14.75	14.88	2.44	1-1/2	12.75	10.00	3.19	4.75	1.00		
324T-326TS	15.50	8.00	6.25	.88	.69	2.75	4.50	16.69	17.00	2.44	2	15.19	11.44	4.25	5.25	1.36		
364T-365TS	17.00	9.00	7.00	.88	.69	2.75	3.88	18.50	19.50	2.94	3	18.06	14.00	5.38	5.88	1.38		
404T-405TS	19.00	10.00	8.00	1.12	.81	3.25	4.62	21.31	22.50	2.94	3	19.31	15.25	5.38	6.62	1.13		
444T-445TS	21.00	11.00	9.00	1.12	.81	3.25	5.25	23.38	25.25	3.25	3	23.38	18.12	6.50	7.50	1.25		

FRAME SIZE	DIMENSIONS ARE IN INCHES; SEE SHEET 2 FOR DIMENSIONS IN MILLIMETERS											SHAFT AND KEY						WEIGHT (LBS.) (5)
	C	BS	B	2F	(4) 2XF	N	N-W(6)	U(3)	V	SQ.	LGTH.	W(5)						
254T	24.56	5.00	12.00	---	8.25	4.12	4.00	1.625	3.75	.375	2.88	305						
256T	24.96	5.00	12.00	10.00	---	4.12	4.00	1.625	3.75	.375	2.88	315						
284T	27.44	5.50	13.00	---	9.50	5.00	4.62	1.875	4.38	.500	3.25	435						
284TS	26.06	5.50	13.00	---	9.50	5.00	3.62	1.625	3.00	.375	1.88	435						
286T	27.44	5.50	13.00	11.00	---	5.00	4.62	1.875	4.38	.500	3.25	450						
286TS	26.06	5.50	13.00	11.00	---	3.62	3.25	1.625	3.00	.375	1.88	450						
324T	30.44	6.00	14.75	---	10.50	5.62	5.25	2.125	5.00	.500	3.88	540						
324TS	28.94	6.00	14.75	12.00	---	4.12	3.75	1.875	3.50	.500	2.00	540						
326T	30.44	6.00	14.75	12.00	---	5.62	5.25	2.125	5.00	.500	3.88	580						
326TS	28.94	6.00	14.75	12.00	---	4.12	3.75	1.875	3.50	.500	2.00	580						
364T	33.44	6.12	15.00	---	11.25	6.25	5.88	2.375	5.62	.625	4.25	794						
364TS	31.31	6.12	15.00	---	11.25	4.12	3.75	1.875	3.50	.500	2.00	794						
365T	33.44	6.12	15.00	12.25	---	6.25	5.88	2.375	5.62	.625	4.25	840						
365TS	31.31	6.12	15.00	12.25	---	4.12	3.75	1.875	3.50	.500	2.00	834						
404T	38.31	6.88	16.00	---	12.25	7.50	7.25	2.875	7.00	.750	5.62	1120						
404TS	35.31	6.88	16.00	---	12.25	4.50	4.25	2.125	4.00	.500	2.75	1111						
405T	38.31	6.88	16.00	13.75	---	7.50	7.25	2.875	7.00	.750	5.62	1160						
405TS	35.31	6.88	16.00	13.75	---	4.50	4.25	2.125	4.00	.500	2.75	1151						
444T	44.62	8.25	19.00	---	14.50	8.94	8.50	3.375	8.25	.875	6.88	1524						
444TS	40.88	8.25	19.00	16.50	---	5.19	4.75	2.375	4.50	.625	3.00	1714						

- (1) SPECIAL DIMENSIONS APPLYING TO THIS ORDER ON THIS LINE. CONDUIT BOX LOCATED ON OPPOSITE SIDE WHEN F-2-W-1, W-4, W-5, W-7, OR C-1 MOUNTING IS SPECIFIED.
- (2) "D" VARIES [250T - 320T +.00, -.03, 360T - 440T +.00, -.06. IF MOUNTING CLEARANCE DETAILS ARE REQUIRED, CONSULT FACTORY.
- (3) "J" VARIES [UP TO 1.625 DIA. +.0000, -.0005 1.625 AND LARGER +.000, -.001. MAXIMUM PERMISSIBLE SHAFT RUNOUT WHEN MEASURED AT END OF STD. SHAFT EXTENSION IS .002 T.I.R. UP TO AND INCLUDING 1.625 DIA. AND .003 T.I.R. 1.625 DIA. TO 5 INCH DIA.
- (4) ALL FRAMES HAVE EIGHT MOUNTING HOLES FOR DUAL MOUNTING.
- (5) MOTOR WEIGHTS MAY VARY BY 15% DEPENDING UPON RATING.
- (6) "N-W" VARIES +.00, -.25.

FRAME- _____ TYPE- _____ CERTIFIED FOR- _____
 ORDER- _____ ITEM- _____ HP- _____ RPM- _____ PH- _____ HZ- _____ VOLTS- _____
 RELIANCE SALES ORDER- _____ APPROVED BY- _____ DATE _____

CUSTOMER IS RESPONSIBLE FOR DETERMINING THAT BALDOR'S PRODUCT WILL PERFORM SUITABLY IN THE INTENDED APPLICATION.

REV. DESC: UPDATE TITLE SHEET 2		TDR: 00000498266	
REV. LTR: B	VERSION: 02	REVISED: 07:05:46 04/29/2009	
FILE: \RAG\00000\167		BY: RAGEC	
MTL: -			

Baldor • Dodge • Reliance

DIM SHEET 250T THRU 440T