

RPM-AC FINNED FRAME VARIABLE SPEED ALTERNATING CURRENT MOTOR FL2162C

ENCLOSURE: TOTALLY ENCLOSED
MOUNTING: FOOT / NEMA 210TC C-FACE
DRIVE METHOD: COUPLED OR BELTED

COOLING: NON-VENTILATED

ACCESSORIES: PROVISIONS FOR
TACHOMETER MOUNTING
ONLY WHEN SPECIFIED

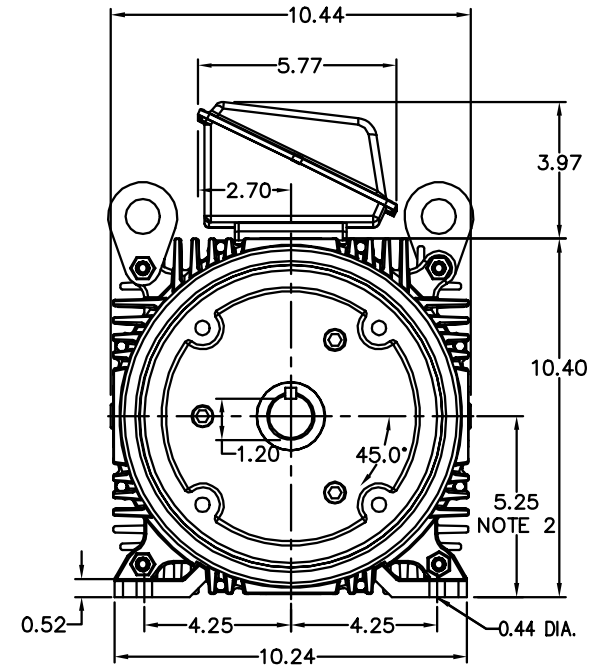
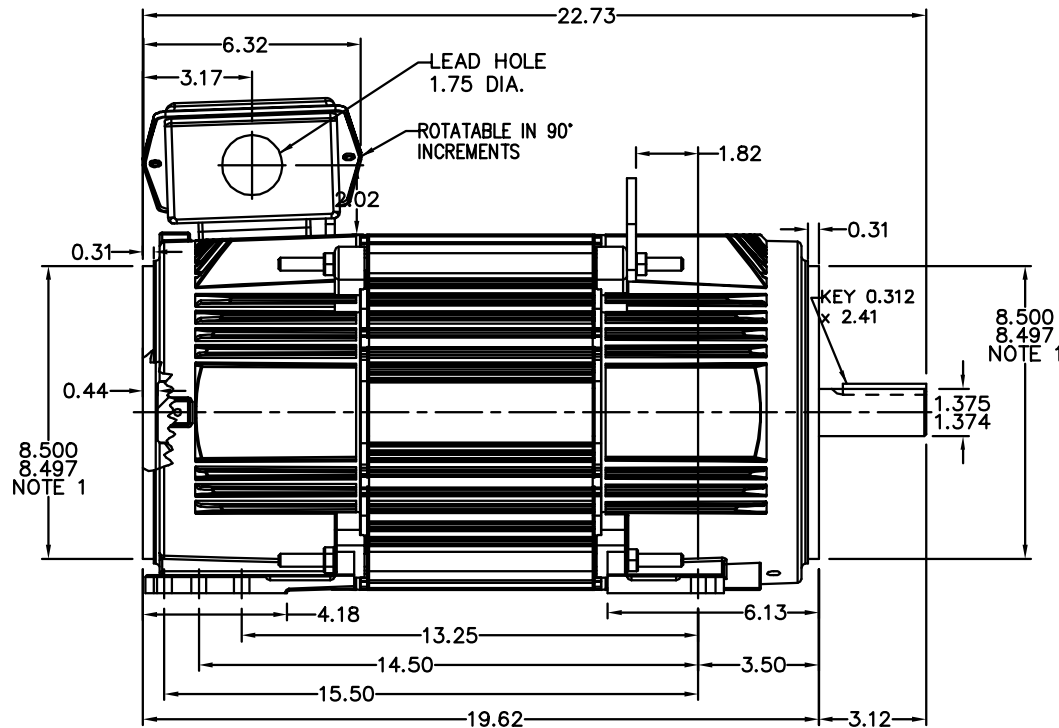

- NOTE 1: C-FACE & TACHOMETER MOUNTING
1/2-13 TAP, 1.00 DEEP, ON A 7.25 DIA. BOLT CIRCLE
FACE RUNOUT AND ECCENTRICITY 0.004 MAX. T.I.R.
- NOTE 2: SHAFT HEIGHT WILL NOT BE EXCEEDED
SHIMS UP TO 0.03 INCHES IN THICKNESS ARE USUALLY
REQUIRED FOR COUPLED OR GREARED MACHINES
- TERMINAL BOX MAY BE LOCATED F1 OR F2 IF SPECIFIED
61 AMP STEEL TERMINAL BOX SHOWN
REFER TO 616779-50 FOR SPECIFIED TERMINAL BOX DIMENSIONS
REFER TO 616779-55 FOR SPECIFIED TACHOMETER DIMENSIONS

MOTOR WEIGHT: 280 LBS. (MAY VARY 15%)
DIMENSIONS ARE IN INCHES SCALE: 1.00

CUSTOMER IS RESPONSIBLE FOR DETERMINING THAT BALDOR'S PRODUCT WILL PERFORM SUITABLY IN THE INTENDED APPLICATION.

REV. DESC: ADDED C-FACE DEPTH DIMENSION	VERSION: 01	TDR: 00000493632
REV. LTR: A	REVISED: 13:15:33 03/13/2009	BY: CONDLM
FILE: \RGG\00003\180		
MTL: -		

BALDOR • DODGE • RELIANCE

DIM SHT RPMAC TENV FL2162C FT MT PROV FOR TACH
SH 1 of 1