

RPM-AC FINNED FRAME VARIABLE SPEED ALTERNATING CURRENT MOTOR FL2898Z

ENCLOSURE: TOTALLY ENCLOSED

MOUNTING: FOOT

DRIVE METHOD: COUPLED OR BELTED

COOLING: FAN COOLED

ACCESSORIES: PROVISIONS FOR TACHOMETER MOUNTING ONLY WHEN SPECIFIED

617248-001

D

C

B

A

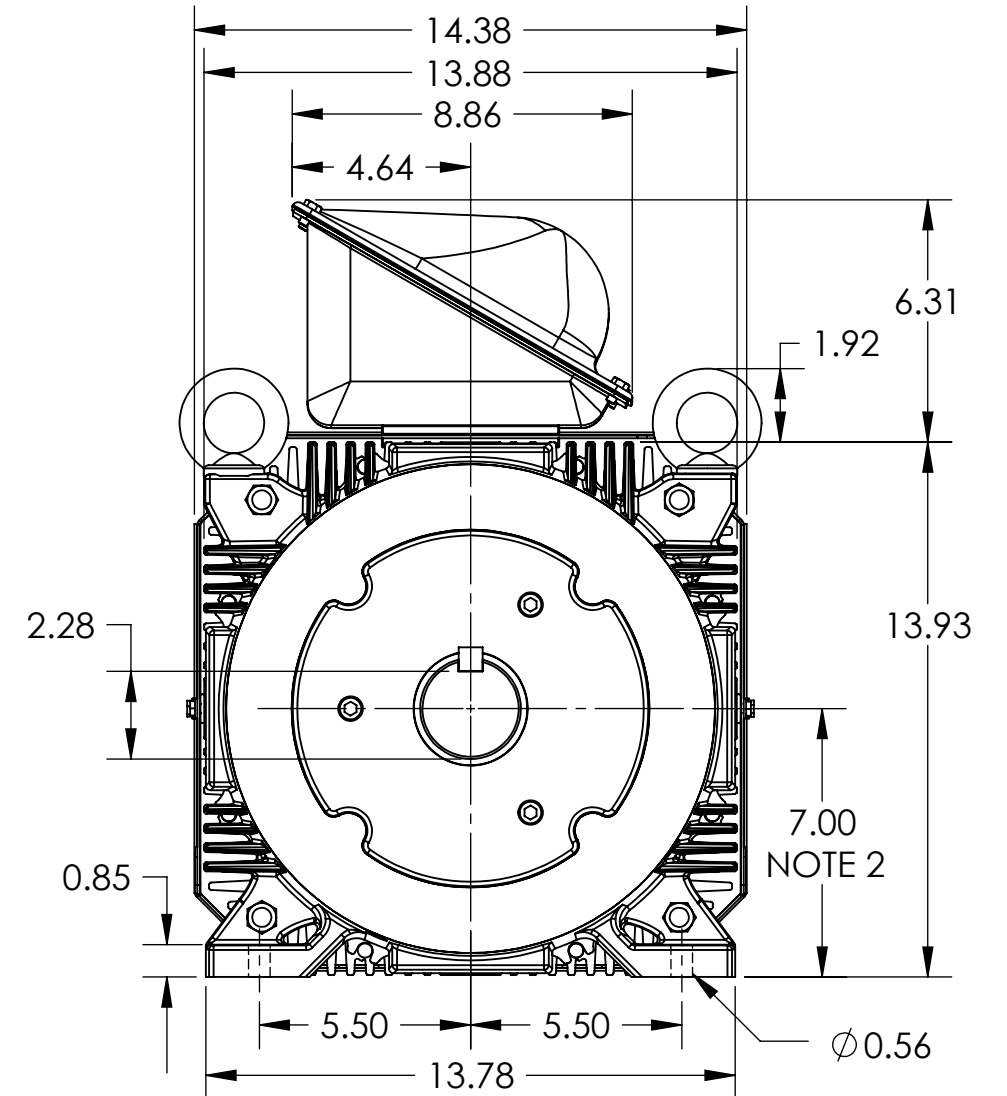
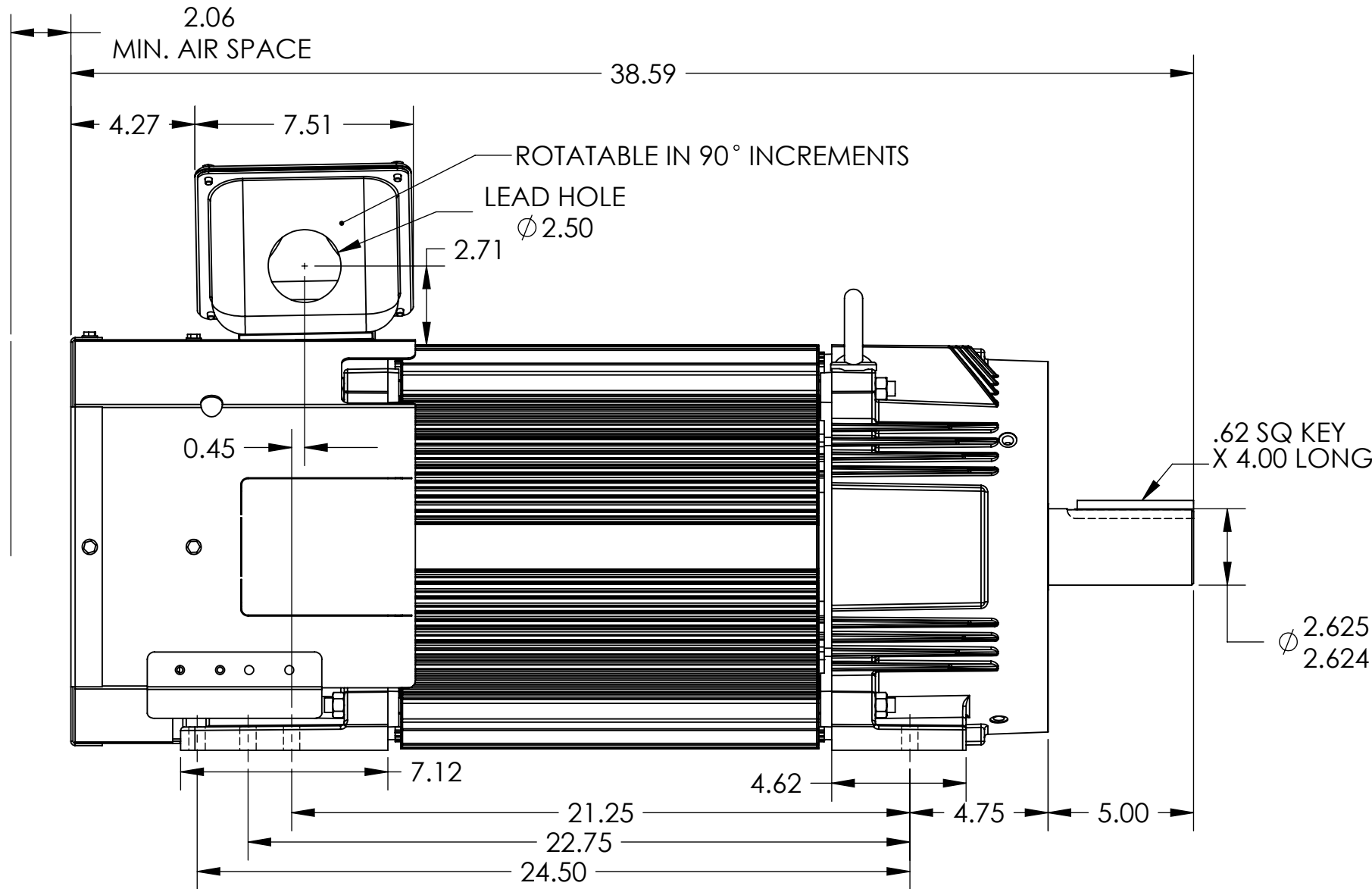

TERMINAL BOX MAY BE LOCATED F1 OR F2 IF SPECIFIED
160 AMP STEEL TERMINAL BOX SHOWN
REFER TO 616779-50 FOR SPECIFIED TERMINAL BOX DIMENSIONS
REFER TO 616779-55 FOR SPECIFIED TACHOMETER DIMENSIONS

DIMENSIONS ARE IN INCHES

MOTOR WEIGHT: 880 LBS. (MAY VARY 15%)

CUSTOMER IS RESPONSIBLE FOR DETERMINING THAT BALDOR'S PRODUCT WILL PERFORM SUITABLY IN THE INTENDED APPLICATION

NOTE 1: O.D.E. C-FACE & TACHOMETER MOUNTING
1/2-13 TAP, 1.00 DEEP, ON A Ø 7.25 B.C.
FACE RUNOUT AND ECCENTRICITY 0.004 MAX. T.I.R.

NOTE 2: SHAFT HEIGHT WILL NOT BE EXCEEDED
SHIMS UP TO 0.03 INCHES IN THICKNESS ARE USUALLY
REQUIRED FOR COUPLED OR GEARED MACHINES

REV. DESC: LOAD SOLID WORKS DIM SHEET AND ASSY TO BUS			
REV: A	VERSION: 01	REVISED: 02:41:49 06/17/2010	TDR: 000000545011
MODEL NO. FL280_TFC		REF:	
BY: MGH TLC		B	

BALDOR

DIM SHT FL2898Z RPM AC TEFC PROV FOR TACH FT MTG

617248-001

8 7 6 5 4 3 2 1

8 7 6 5 4 3 2 1