

617243-001

ENCLOSURE: DRIP PROOF
 MOUNTING: FOOT
 DRIVE METHOD: COUPLED OR BELTED

RPMAC VARIABLE SPEED ALTERNATING CURRENT MOTOR RL2882Z & URL2882Z

COOLING: FORCE VENTILATED
 ACCESSORIES: PROVISIONS FOR
 TACHOMETER MOUNTING
 ONLY WHEN SPECIFIED

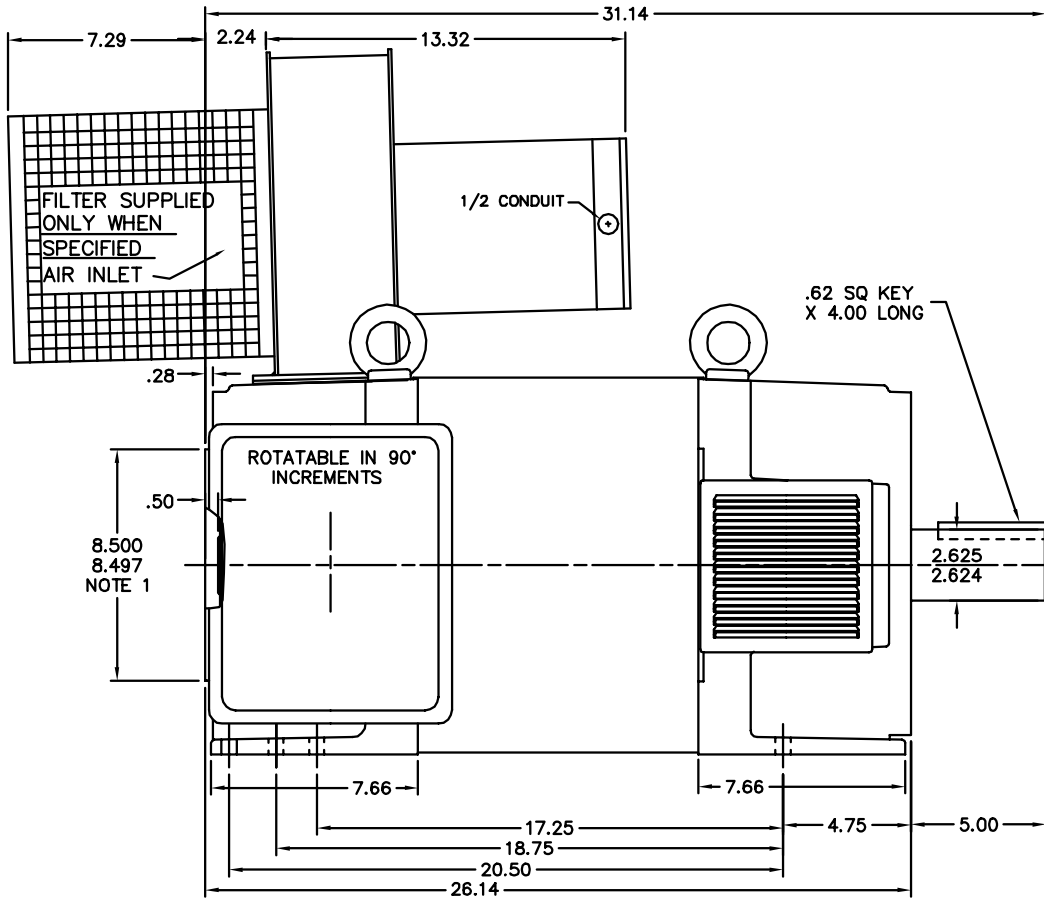

REFER TO MOTOR SPECIFICATION
 FOR LOCATIONS OF BLOWER
 3, 6, 9 OR 12 O'CLOCK AND
 CONDUIT BOX F1, F2 OR F3

BLOWER AND TERMINAL BOX MAY
 NOT BE IN THE SAME LOCATION.

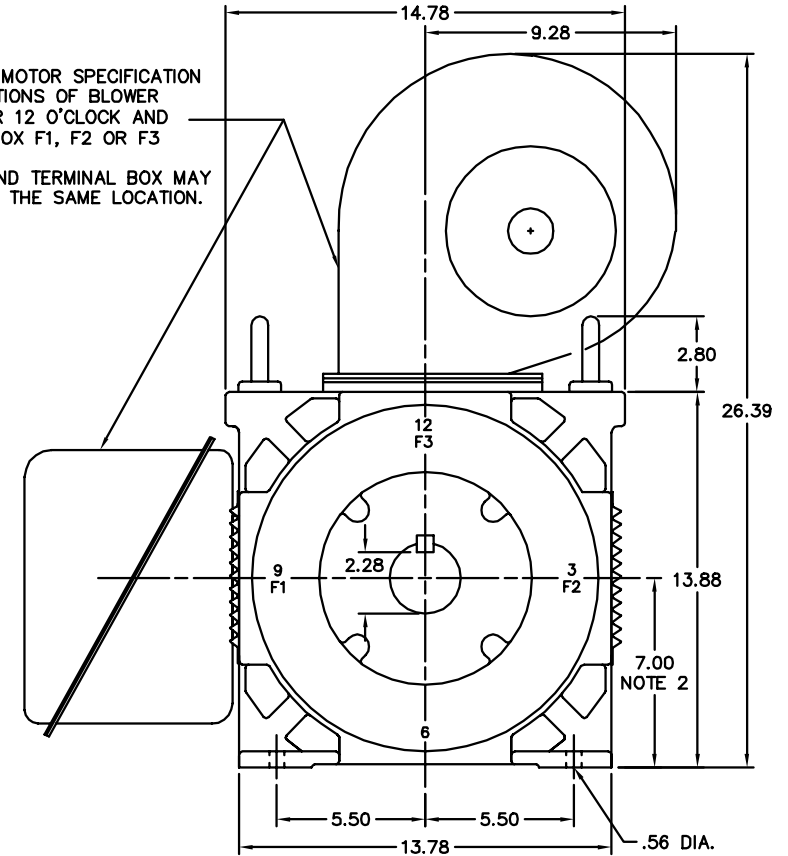

DIMENSIONS ARE IN INCHES SCALE 1:1
 MOTOR WEIGHT 770 LBS. (MAY VARY 15%)

- NOTE 1 TACHOMETER MOUNTING
 1/2-13 TAP, .88 DEEP, ON A 7.25 DIA. BOLT CIRCLE
 FACE RUNOUT AND ECCENTRICITY .004 MAX. T.I.R.
- NOTE 2 SHAFT HEIGHT WILL NOT BE EXCEEDED.
 SHIMS UP TO .03 INCHES IN THICKNESS ARE USUALLY
 REQUIRED FOR COUPLED OR GEARED MACHINES.

305 AMP STEEL CONDUIT BOX SHOWN
 REFER TO 616779-50 FOR SPECIFIC CONDUIT BOX DIMENSIONS
 REFER TO 616779-51 FOR SPECIFIC TACHOMETER DIMENSIONS

CUSTOMER IS RESPONSIBLE FOR DETERMINING THAT THIS PRODUCT WILL PERFORM SUITABLY IN THE INTENDED APPLICATION.

REV. DESC: ADD BLOWER AND CONDUIT BOX LOCATION NOTE		
REV. LTR: E	VERSION: 05	TDR: 00001084751
FILE: \RGG\00003\835	REVISED: 09:23:16 09/25/2018	BY: RGGWT
MTL: -		

BALDOR - RELIANCE®

DIM SHT RL2882Z & URL2882Z DPFV PROV FOR TACH FT MTG

SH 1 of 1

617243-001