

617249-001

ENCLOSURE: DRIP PROOF
 MOUNTING: FOOT
 DRIVE METHOD: COUPLED OR BELTED

RPMAC VARIABLE SPEED ALTERNATING CURRENT MOTOR RL2898Z/URL2898

COOLING: FORCE VENTILATED
 ACCESSORIES: PROVISIONS FOR
 TACHOMETER MOUNTING
 ONLY WHEN SPECIFIED

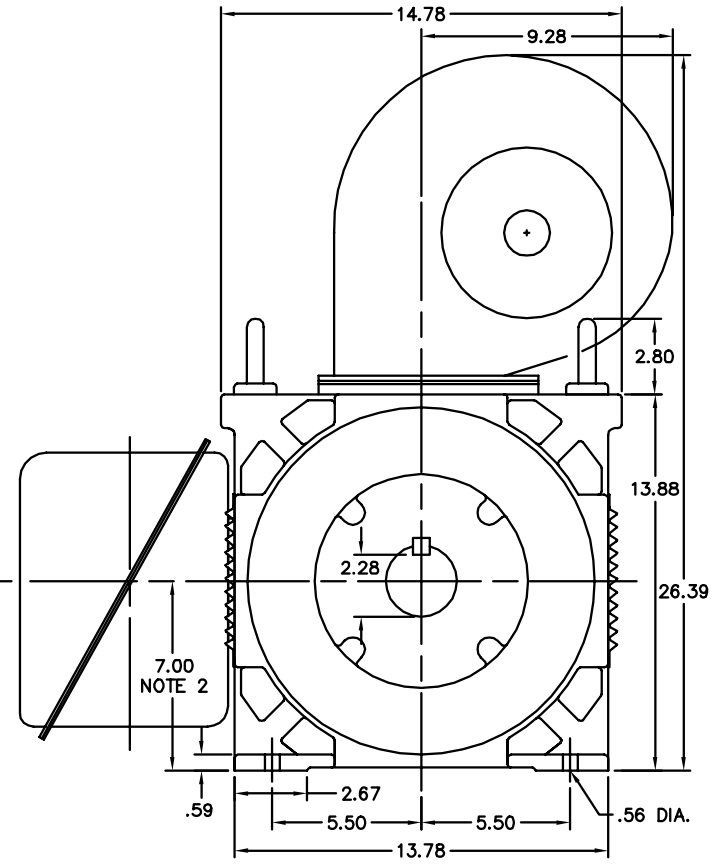
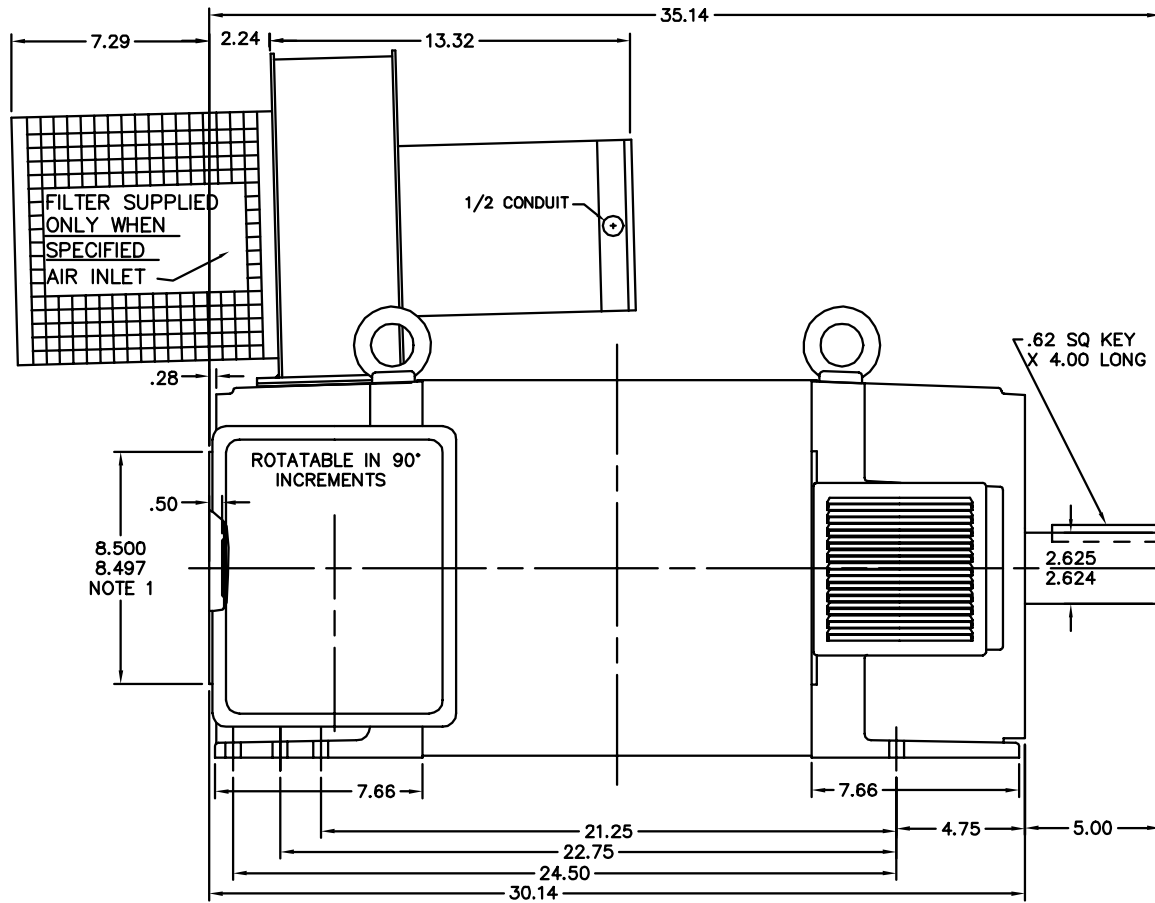

DIMENSIONS ARE IN INCHES SCALE 1:1

NOTE 1 TACHOMETER MOUNTING
 1/2-13 TAP, .88 DEEP, ON A 7.25 DIA. BOLT CIRCLE
 FACE RUNOUT AND ECCENTRICITY .004 MAX. T.I.R.

NOTE 2 SHAFT HEIGHT WILL NOT BE EXCEEDED.
 SHIMS UP TO .03 INCHES IN THICKNESS ARE USUALLY
 REQUIRED FOR COUPLED OR GEARED MACHINES.

TERMINAL BOX MAY BE LOCATED F1 OR F2 IF SPECIFIED
 305 AMP STEEL TERMINAL BOX SHOWN
 REFER TO 616779-50 FOR SPECIFIC TERMINAL BOX DIMENSIONS
 REFER TO 616779-51 FOR SPECIFIC TACHOMETER DIMENSIONS
 MOTOR WEIGHT 930 LBS. (MAY VARY 15%)

CUSTOMER IS RESPONSIBLE FOR DETERMINING THAT BALDOR'S PRODUCT WILL PERFORM SUITABLY IN THE INTENDED APPLICATION.

REV. DESC: ADD FRAME URL2898 TO D/S		
REV. LTR: C	VERSION: 03	TDR: 00000737252
FILE: \RGG\00003\848	REVISED: 07:54:08 03/08/2012	BY: RGGWT
MTL: -		

BALDOR

DIM SHT RL2898Z RPM AC DPFV PROV FOR TACH FT MTG
 SH 1 of 1

617249-001