

RPM-AC FINNED FRAME VARIABLE SPEED ALTERNATING CURRENT MOTOR FL1844CZ

ENCLOSURE: DRIP PROOF
MOUNTING: FOOT / NEMA 250TC C-FACE
DRIVE METHOD: COUPLED OR BELTED

COOLING: FORCE VENTILATED
ACCESSORIES: PROVISIONS FOR TACHOMETER MOUNTING ONLY WHEN SPECIFIED

617233-023

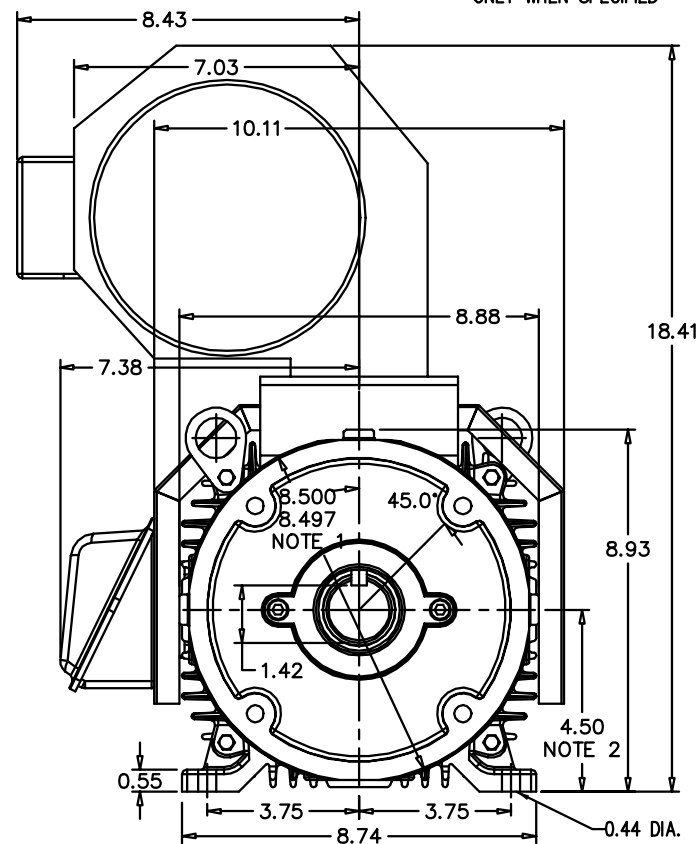
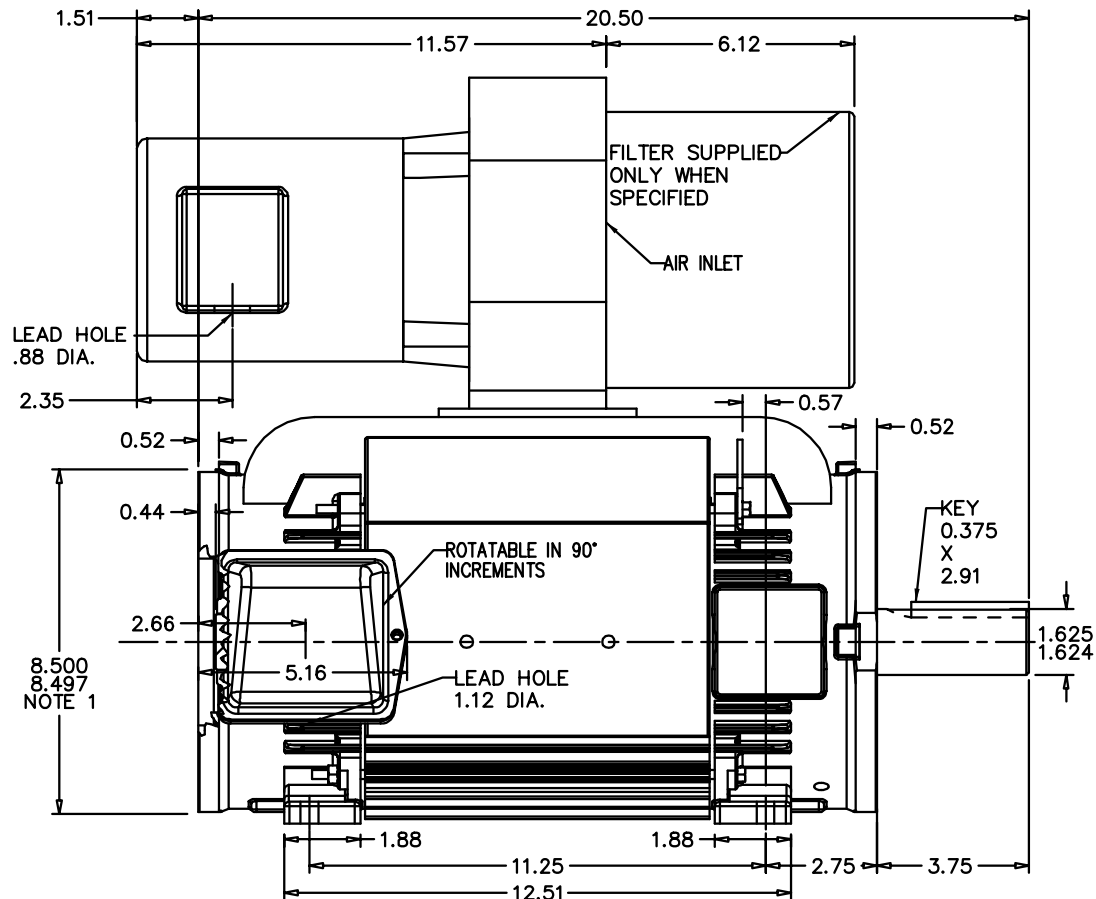

NOTE 1: C-FACE & TACHOMETER MOUNTING
1/2-13 TAP, 1.00 DEEP, ON A 7.25 DIA. BOLT CIRCLE
FACE RUNOUT AND ECCENTRICITY 0.004 MAX. T.I.R.

NOTE 2: SHAFT HEIGHT WILL NOT BE EXCEEDED
SHIMS UP TO 0.03 INCHES IN THICKNESS ARE USUALLY
REQUIRED FOR COUPLED OR GEARED MACHINES

TERMINAL BOX MAY BE LOCATED F1 OR F2 IF SPECIFIED
40 AMP STEEL TERMINAL BOX SHOWN
REFER TO 616779-50 FOR SPECIFIED TERMINAL BOX DIMENSIONS
REFER TO 616779-55 FOR SPECIFIED TACHOMETER DIMENSIONS

MOTOR WEIGHT: 200 LBS. (MAY VARY 15%)
DIMENSIONS ARE IN INCHES SCALE: 1.00

CUSTOMER IS RESPONSIBLE FOR DETERMINING THAT BALDOR'S PRODUCT WILL PERFORM SUITABLY IN THE INTENDED APPLICATION.

REV. DESC: SEE TDR.	VERSION: 03	TDR: 00000751510
REV. LTR: C	REVISED: 03:49:41 06/13/2012	BY: RGGJGG
FILE: \RGG\00003\415		
MTL: -		

BALDOR

DIM SH 250TC RPMAC DPFV FL1844CZ FT MT PROV FOR TACH
SH 1 of 1

617233-023