

RPM-AC FINNED FRAME VARIABLE SPEED ALTERNATING CURRENT MOTOR FL2173Z

ENCLOSURE: TOTALLY ENCLOSED
MOUNTING: FOOT
DRIVE METHOD: COUPLED OR BELTED

COOLING: BLOWER COOLED or FAN COOLED
ACCESSORIES: PROVISIONS FOR TACHOMETER MOUNTING ONLY WHEN SPECIFIED

617525-001

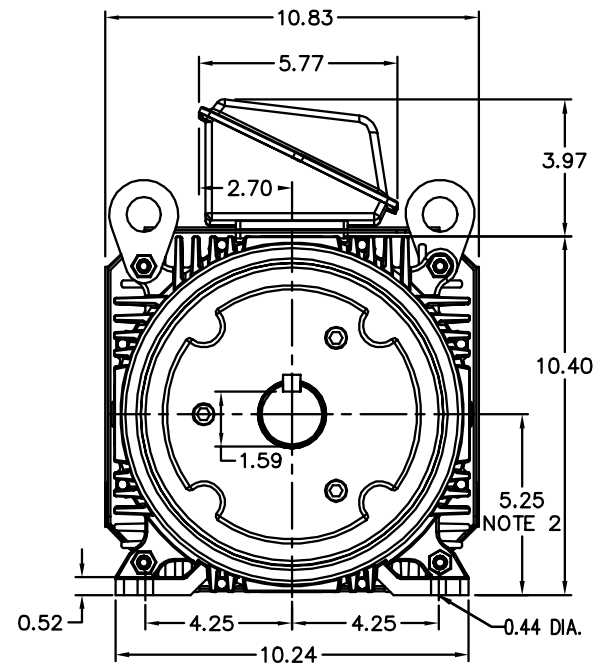
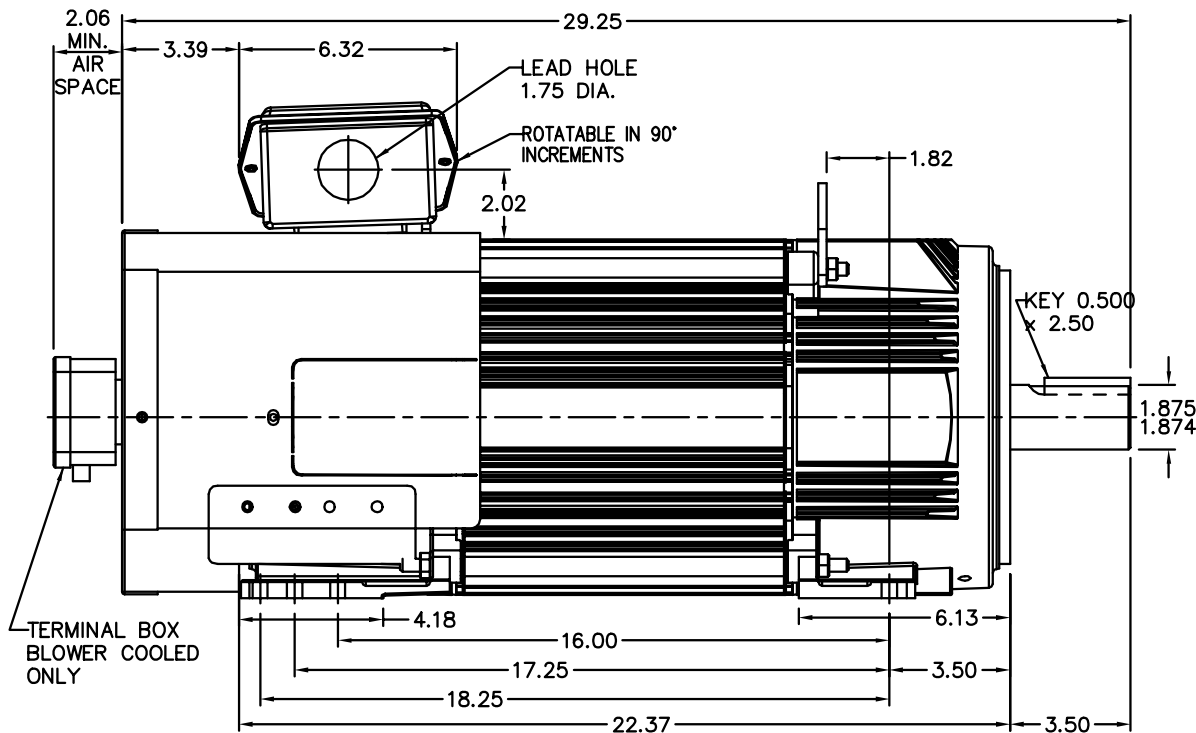

NOTE 1: C-FACE & TACHOMETER MOUNTING
1/2-13 TAP, 1.00 DEEP, ON A 7.25 DIA. BOLT CIRCLE
FACE RUNOUT AND ECCENTRICITY 0.004 MAX. T.I.R.

NOTE 2: SHAFT HEIGHT WILL NOT BE EXCEEDED
SHIMS UP TO 0.03 INCHES IN THICKNESS ARE USUALLY
REQUIRED FOR COUPLED OR GREARED MACHINES

TERMINAL BOX MAY BE LOCATED F1 OR F2 IF SPECIFIED
61 AMP STEEL TERMINAL BOX SHOWN
REFER TO 616779-50 FOR SPECIFIED TERMINAL BOX DIMENSIONS
REFER TO 616779-55 FOR SPECIFIED TACHOMETER DIMENSIONS

MOTOR WEIGHT: 355 LBS. (MAY VARY 15%)
DIMENSIONS ARE IN INCHES SCALE: 1.00

CUSTOMER IS RESPONSIBLE FOR DETERMINING THAT BALDOR'S PRODUCT WILL PERFORM SUITABLY IN THE INTENDED APPLICATION.

REV. DESC: ASSIGNED TO BUSLOAD	VERSION: 00	TDR: 000000480001
REV. LTR: -	REVISED: 11:26:23 10/31/2008	BY: CONBAT
FILE: \RGG\00003\238		
MTL: -		

BALDOR • DODGE • RELIANCE

DIM SHT FL2173Z RPM AC TEBC/FC PROV FOR TACH WHEN SPEC

SH 1 of 1

617525-001