

DUTY MASTER ALTERNATING CURRENT MOTORS

SQUIRREL-CAGE INDUCTION

CAST IRON CONSTRUCTION

FRAMES E364T THRU E365T

ENCLOSURE: TOTALLY ENCLOSED

MOUNTING: FOOT/F1

COOLING: FAN COOLED

617428-012

D

C

B

A

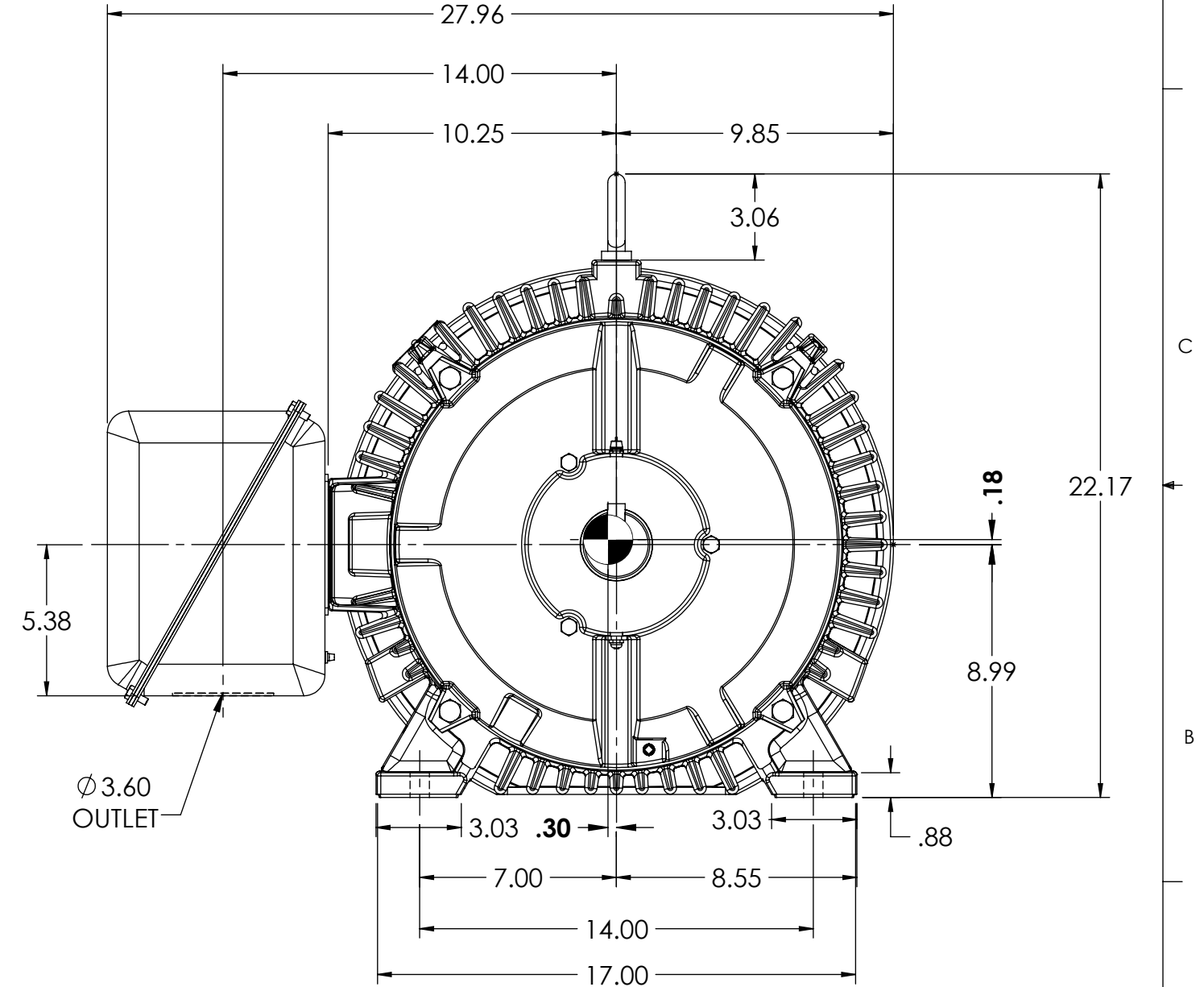
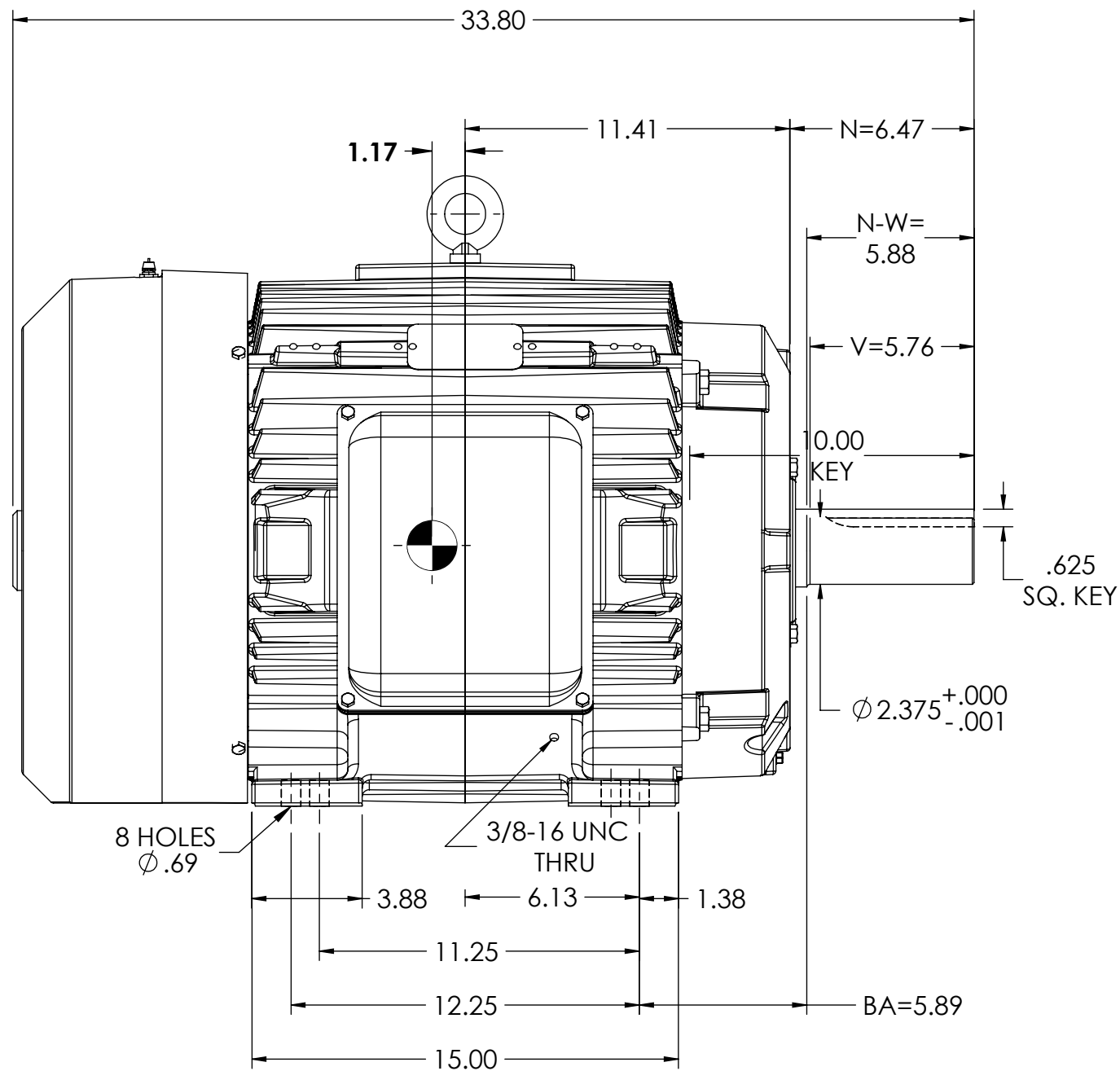

- DENOTES CENTER OF GRAVITY WHICH MAY VARY ±1.00 INCH.

WEIGHT (LBS): 840, MOTOR WEIGHTS MAY VARY BY 15% DEPENDING UPON RATING.
 MAXIMUM PERMISSIBLE SHAFT RUNOUT WHEN MEASURED AT END OF STD. SHAFT EXTENSION .003 T.I.R.
 CUSTOMER IS RESPONSIBLE FOR DETERMINING THAT BALDOR'S PRODUCT WILL PERFORM SUITABLY IN THE INTENDED APPLICATION.

REV. DESC: CHG TITLE TO SAY 364 FRAME			
REV: D	VERSION: 04	REVISED: 02:43:45 06/11/2019	TDR: 000001110771
MODEL NO. 617428-012			REF:
BY: RAGEC			B

BALDOR

E364/365T TEFC F1 FOOT STEEL CONDUIT BOX/CENTER OF GRAVITY

617428-012

8

7

6

5

4

3

2

1