

# DUTY MASTER ALTERNATING CURRENT MOTORS

SQUIRREL-CAGE INDUCTION  
CAST IRON CONSTRUCTION

ENCLOSURE: TOTALLY ENCLOSED  
MOUNTING: FOOT

FRAMES 364T-365T

COOLING: FAN COOLED

617428-011

D

D

C

C

B

B

A

A

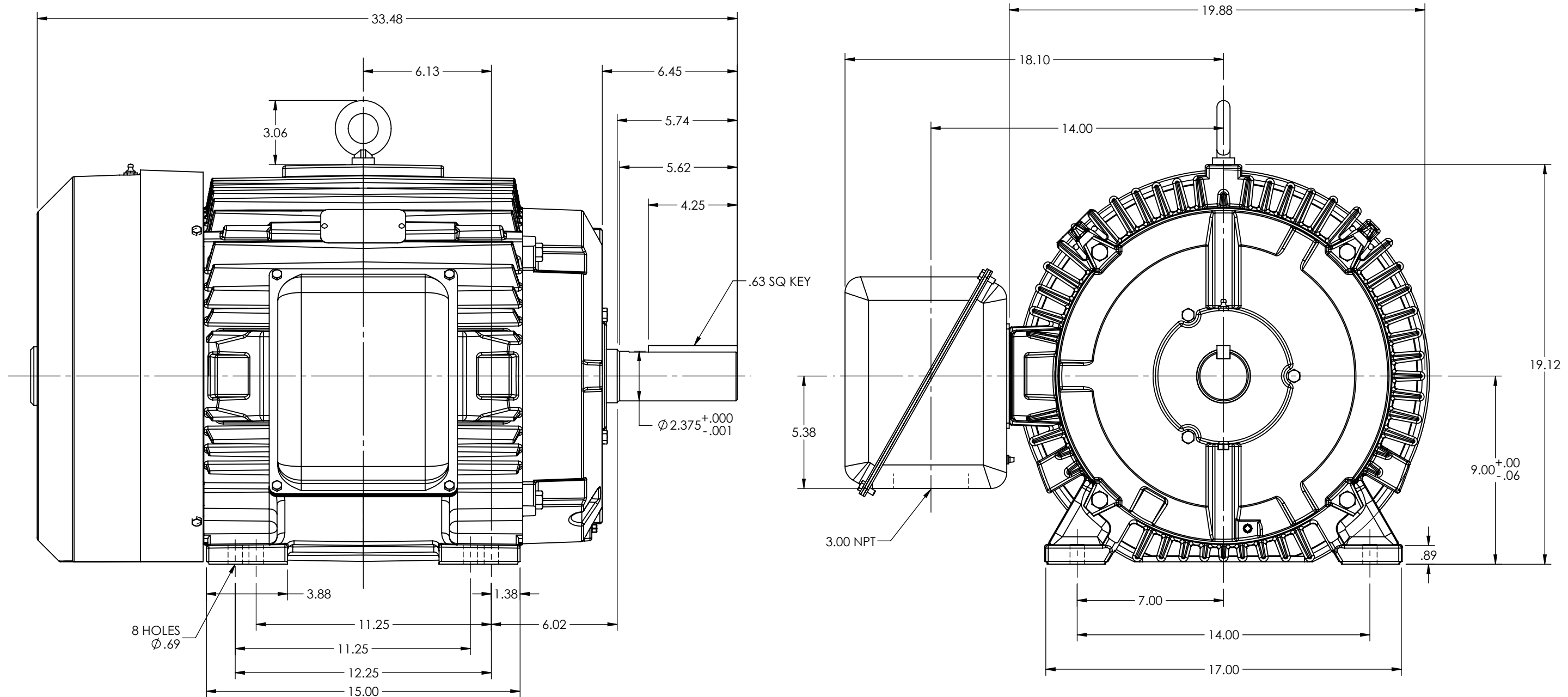

MAXIMUM PERMISSIBLE SHAFT RUNOUT WHEN MEASURED AT END OF STD. SHAFT EXTENSION IS .002 T.I.R. UP TO AND INCLUDING 1.625 DIA. AND .003 T.I.R. 1.625 DIA. TO 5 INCH DIA.

WEIGHT (LBS): 364T = 800  
365T = 840

MOTOR WEIGHTS MAY VARY BY 15% DEPENDING UPON RATING.

CUSTOMER IS RESPONSIBLE FOR DETERMINING THAT BALDOR'S PRODUCT WILL PERFORM SUITABLY IN THE INTENDED APPLICATION

REV. DESC: NEW FROM 611740-001			
REV: -	VERSION: 00	REVISED: 08:16:00 07/11/2013	TDR: 000000807721
MODEL NO. 617428-011			REF:
BY: ENBUCF0			<b>B</b>

## BALDOR

DIM SHT TEFC 364-365T FT MTG W/GRSR AND PLUGS

617428-011

8 7 6 5 4 3 2 1