

DUTY MASTER ALTERNATING CURRENT MOTORS

SQUIREL-CAGE INDUCTION
CAST IRON CONSTRUCTION

ENCLOSURE: PROTECTED
MOUNTING: FOOT

FRAMES 250T THRU 440T

COOLING: SELF-VENTILATED

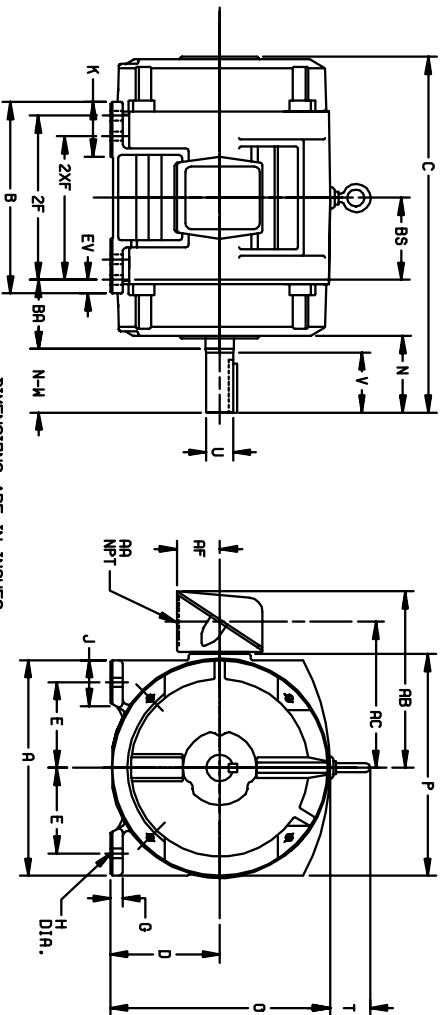

DIMENSIONS ARE IN INCHES

FRAME	A	D(2)	E	G	H	J	K	D	P	T	CAST IRON TERMINAL BOX						EV
											AA	AB	AC	AF	BA		
254T-256T	12.50	6.25	5.50	.69	.56	2.25	3.50	12.61	12.69	2.44	1-1/4	10.25	8.25	2.50	4.25	.62	
284T-286T	14.00	7.00	5.50	.75	.56	2.75	3.75	14.12	14.31	2.44	1-1/2	12.06	9.62	3.19	4.75	1.00	
324T-326T	15.75	8.00	6.25	.88	.69	3.12	4.00	16.10	16.42	2.44	2	14.75	11.00	3.62	5.25	1.00	
364T-365T	17.00	9.00	7.00	.88	.69	3.00	3.62	18.30	19.56	2.94	3	18.00	13.81	4.12	5.88	1.00	
404T-405T	19.00	10.00	8.00	1.12	.81	3.25	4.75	20.56	21.81	2.94	3	19.00	14.81	3.12	6.62	1.12	
444T-445T	21.00	11.00	9.00	1.12	.81	3.25	5.25	22.91	23.62	3.25	3	21.44	16.69	5.00	7.50	1.25	

FRAME SIZE	C	BS	B	BF	2XF	N	SHAFT AND KEY										WEIGHT LBS. (3)
							N-V(6)	U(2)	V	SR	LGTH	LBS.					
254T	22.44	5.00	11.25	---	8.25	4.25	4.00	1.625	3.75	3.75	2.75	2.75	2.75	2.65			
256T	22.44	5.00	11.25	---	4.25	4.00	1.625	3.75	3.75	3.75	2.75	2.75	2.75	2.65			
284T	24.94	5.50	13.00	---	9.50	4.88	4.62	1.875	4.38	5.00	3.25	3.40	3.40	3.40			
284T	23.56	5.50	13.00	---	9.50	3.50	3.25	1.625	3.00	3.75	1.88	3.70	3.70	3.70			
286T	24.94	5.50	13.00	11.00	---	4.88	4.62	1.875	4.38	5.00	3.25	3.25	3.25	3.70			
286T	23.56	5.50	13.00	11.00	---	3.50	3.25	1.625	3.00	3.75	1.88	3.70	3.70	3.70			
286T	27.56	6.00	14.00	---	10.50	5.50	5.25	2.125	5.00	5.00	3.75	3.75	4.80	4.80			
324T	27.56	6.00	14.00	---	10.50	5.50	5.25	2.125	5.00	5.00	2.00	2.00	4.80	4.80			
324T	26.06	6.00	14.00	12.00	---	5.50	5.25	2.125	5.00	5.00	2.00	2.00	5.20	5.20			
364T	26.06	6.00	14.00	12.00	---	4.00	3.75	1.875	3.50	5.00	2.00	2.00	5.20	5.20			
364T	27.58	6.12	14.25	---	11.25	6.12	5.88	2.375	3.50	5.00	2.00	2.00	5.20	5.20			
364T	29.70	6.12	14.25	---	11.25	6.12	5.88	2.375	3.50	5.00	2.00	2.00	7.30	7.30			
364T	27.58	6.12	14.25	---	11.25	6.12	5.88	2.375	3.50	5.00	2.00	2.00	7.30	7.30			
365T	29.70	6.12	14.25	12.25	---	4.00	3.75	1.875	3.50	5.00	2.00	2.00	7.30	7.30			
365T	27.58	6.12	14.25	12.25	---	4.00	3.75	1.875	3.50	5.00	2.00	2.00	7.30	7.30			
404T	34.00	6.88	16.00	---	12.25	7.62	7.25	2.875	7.00	7.50	5.50	5.50	10.45	10.45			
404T	31.00	6.88	16.00	---	12.25	7.62	7.25	2.875	7.00	7.50	5.50	5.50	10.45	10.45			
405T	34.00	6.88	16.00	13.75	---	7.25	7.25	2.875	7.00	7.50	5.50	5.50	10.85	10.85			
405T	31.00	6.88	16.00	13.75	---	4.62	4.25	2.125	4.00	5.00	2.75	2.75	10.80	10.80			
444T	39.56	8.25	19.00	---	14.50	8.94	8.50	3.375	8.25	8.75	6.88	6.88	17.30	17.30			
444T	35.81	8.25	19.00	---	14.50	5.19	4.75	2.375	4.50	6.25	3.00	3.00	17.30	17.30			
445T	39.56	8.25	19.00	16.50	---	8.94	8.50	3.375	8.25	8.75	6.88	6.88	17.70	17.70			
445T	35.81	8.25	19.00	16.50	---	5.19	4.75	2.375	4.50	6.25	3.00	3.00	17.70	17.70			

- (1) SPECIAL DIMENSIONS APPLYING TO THIS ORDER ON THIS LINE. CONDUIT BOX LOCATED ON OPPOSITE SIDE WHEN F-2,V-1, V-4,V-5,W-7, DR C-1 MOUNTING IS SPECIFIED.
- (2) $\frac{1}{2}$ " VARIES $\frac{1}{16}$ " 250T - 320T +.00, -.03
360T - 440T +.00, -.06
- (3) $\frac{1}{4}$ " VARIES +.000, -.001 IF MOUNTING CLEARANCE DETAILS ARE REQUIRED, CONSULT FACTORY.
- (4) ALL FRAMES HAVE EIGHT MOUNTING HOLES FOR DUAL MOUNTING. MAXIMUM PERMISSIBLE SHAFT RUNOUT WHEN MEASURED AT END OF STD. SHAFT EXTENSION IS .002 T.I.R. UP TO AND INCLUDING 1625 DIA. AND .003 T.I.R. ABOVE 1625 TO 5 INCH DIA.
- (5) MOTOR WEIGHTS MAY VARY BY 15% DEPENDING UPON RATING.
- (6) "N-V" VARIES +.00, -.25.

FRAME- _____ TYPE- _____ CERTIFIED FOR- _____
 ORDER- _____ ITEM- _____ HP- _____ RPM- _____ PH- _____ HZ _____ VOLTS _____
 SALES ORDER- _____ APPROVED BY- _____ DATE _____

CUSTOMER IS RESPONSIBLE FOR DETERMINING THAT BALDOR'S PRODUCT WILL PERFORM SUITABLY IN THE INTENDED APPLICATION.

REV. DESC: LOADED TO BUS	VERSION: 01	TDR: 00000546464
REV. LTR: A	REVISED: 03:18:49 06/22/2010	BY: RAGHZT
FILE: \RAG\00009\279		
MTL: -		

BALDOR

DIM SHT-250T-440T

SH 1 of 1