

DUTY MASTER ALTERNATING CURRENT MOTORS

SQUIRREL-CAGE INDUCTION

ENCLOSURE: TOTALLY ENCLOSED

COOLING: FAN COOLED

MOUNTING: FOOT, F-1 SIDE

G449T/G447T FRAME MOUNTING HOLES

ENCLOSURE ENHANCEMENT: 841-XL

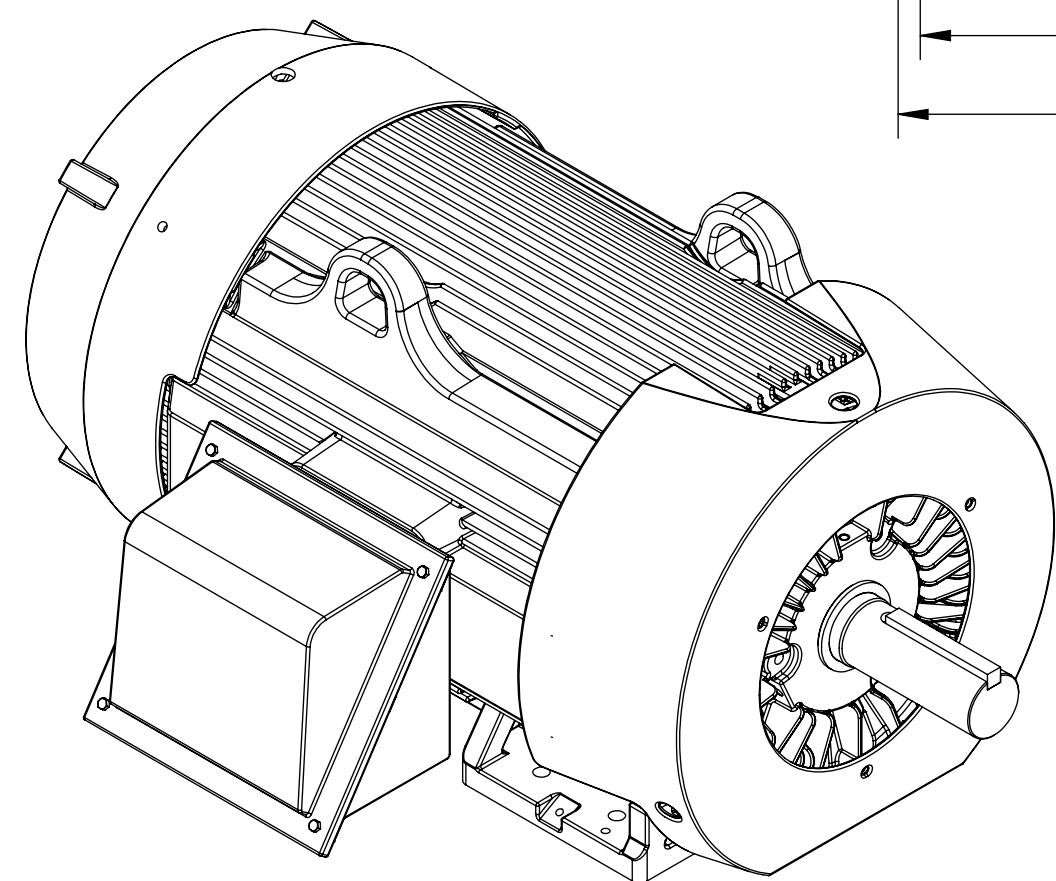
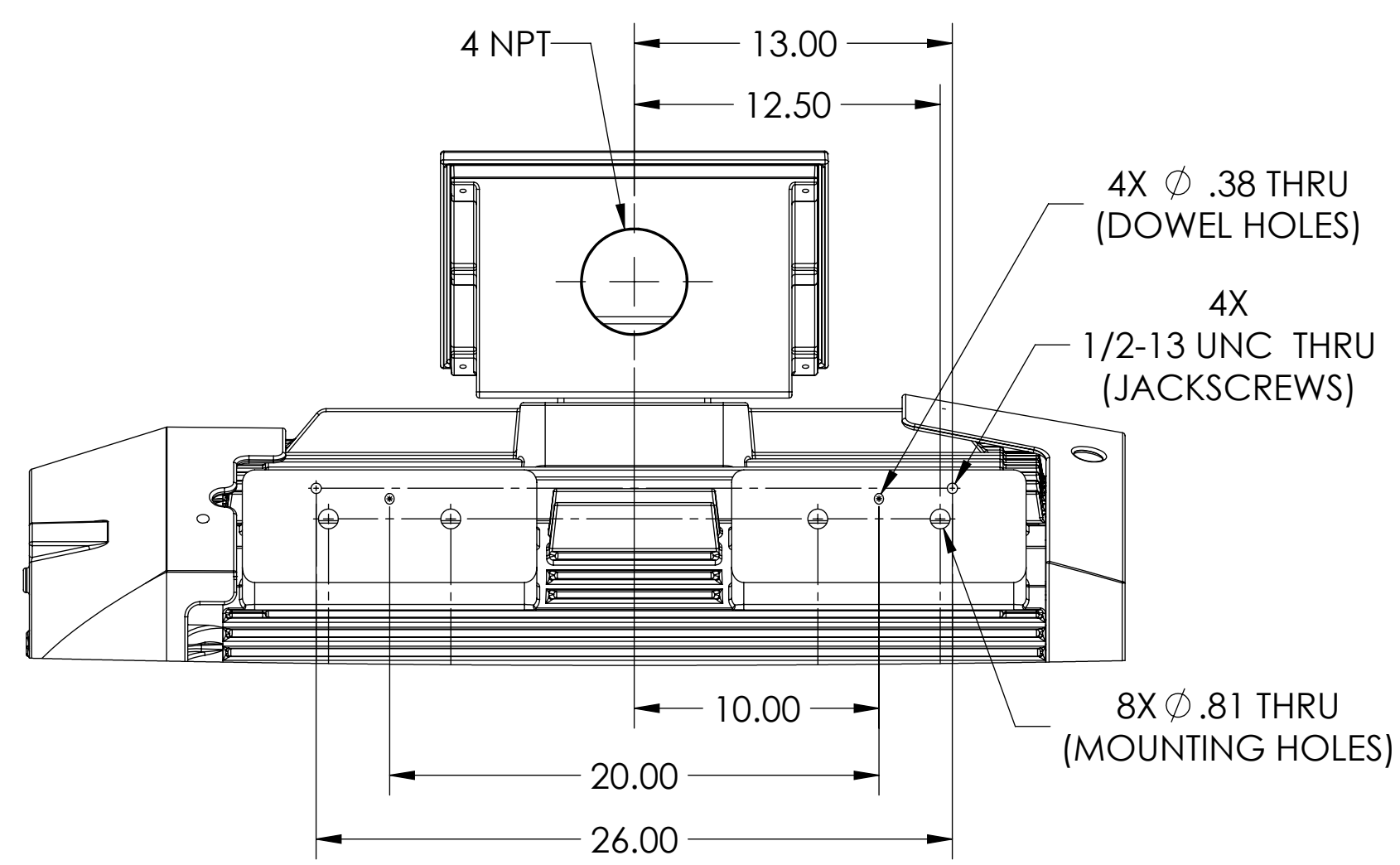
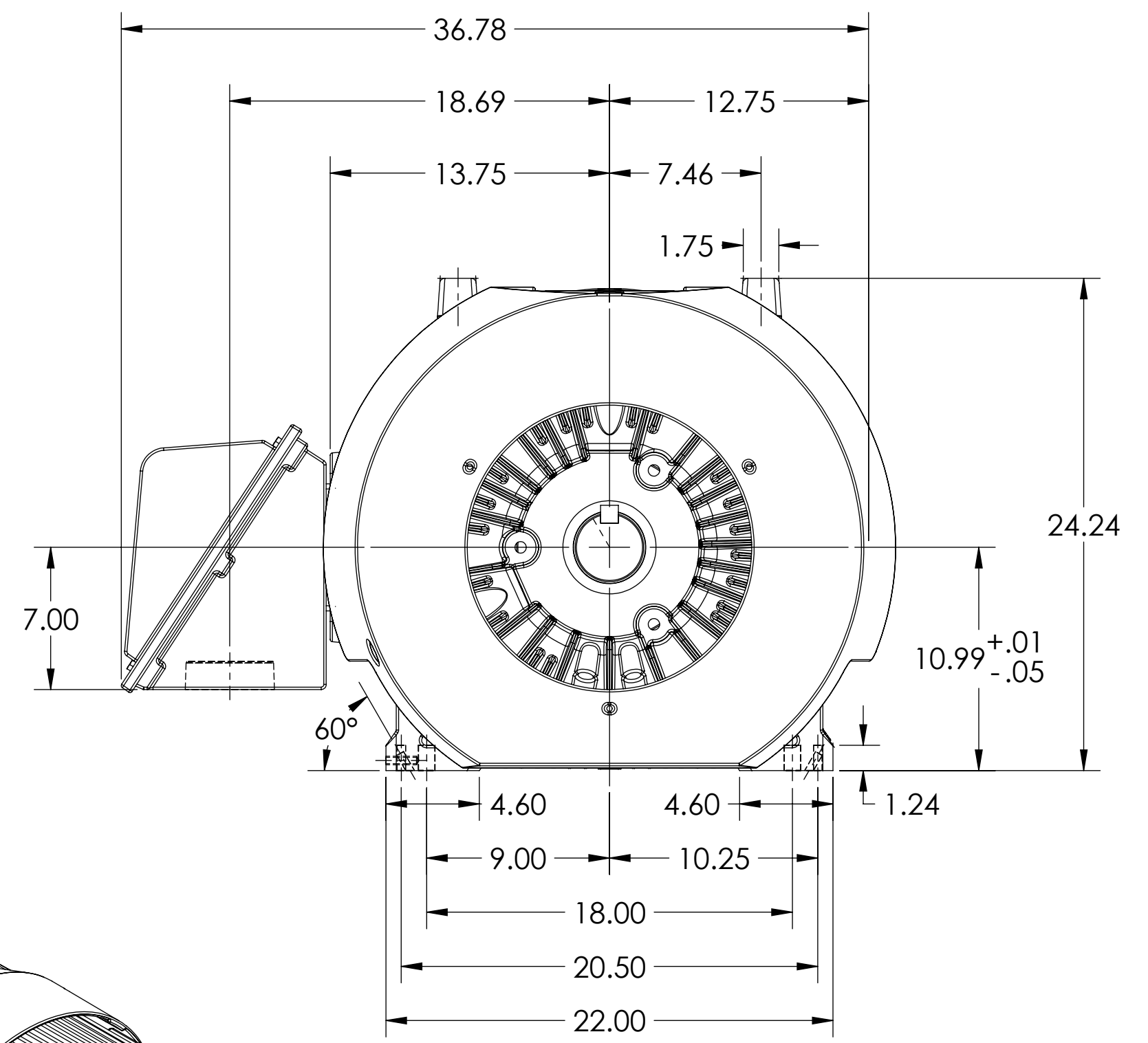
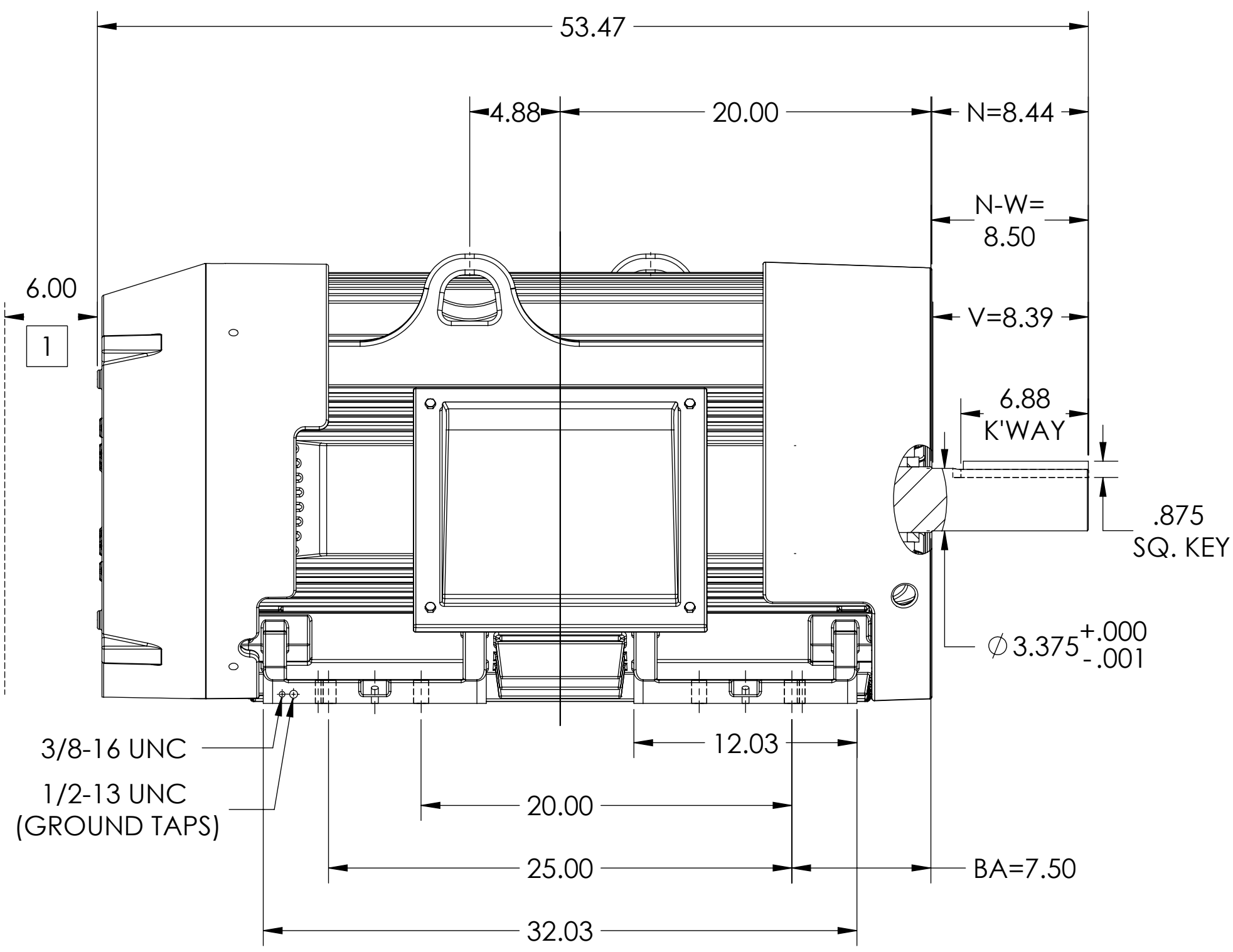

1 OBSTRUCTION MUST NOT ENCROACH ON AIR INLET.

DIMENSIONS ARE IN INCHES.
WEIGHT (LBS): 3080, MOTOR WEIGHTS MAY VARY BY 15% DEPENDING ON RATING.
CUSTOMER IS RESPONSIBLE FOR DETERMINING THAT MOTOR PERFORMANCE IS SUITABLE IN THE APPLICATION.
MAXIMUM PERMISSIBLE SHAFT RUNOUT WHEN MEASURED AT END OF STANDARD SHAFT EXTENSION IS .0015 T.I.R

REV. DESC: NEW DRAWING	VERSION: 00	REVISED: 10:07:48 12/19/2018	TDR: 000001093412
MODEL NO. 617434-665			
BY: USJEDIL			

BALDOR

G449/447T TEFC FOOT F1 C1 BOX/JACKSCREWS/DOWEL PINS/INPROS

DUTY MASTER ALTERNATING CURRENT MOTORS

SQUIRREL-CAGE INDUCTION

ENCLOSURE: TOTALLY ENCLOSED

COOLING: FAN COOLED

MOUNTING: FOOT, F-1 SIDE

G449T/G447T FRAME MOUNTING HOLES

ENCLOSURE ENHANCEMENT: 841-XL

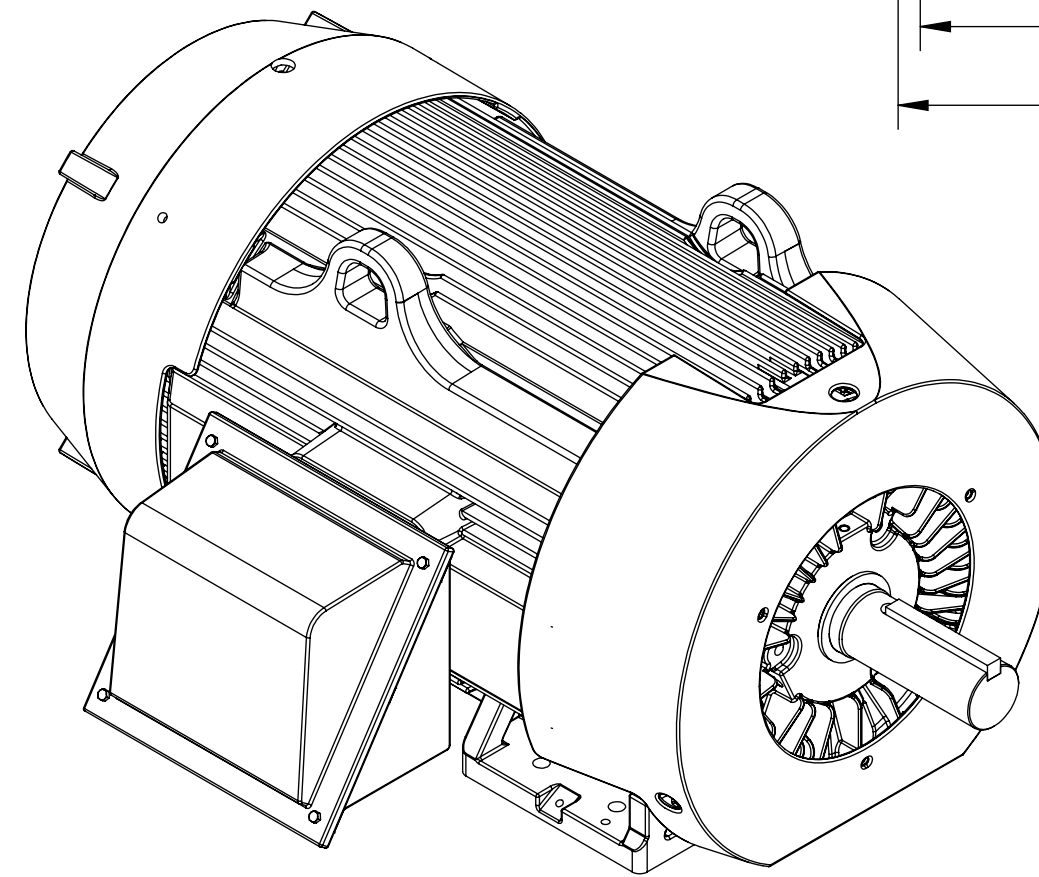
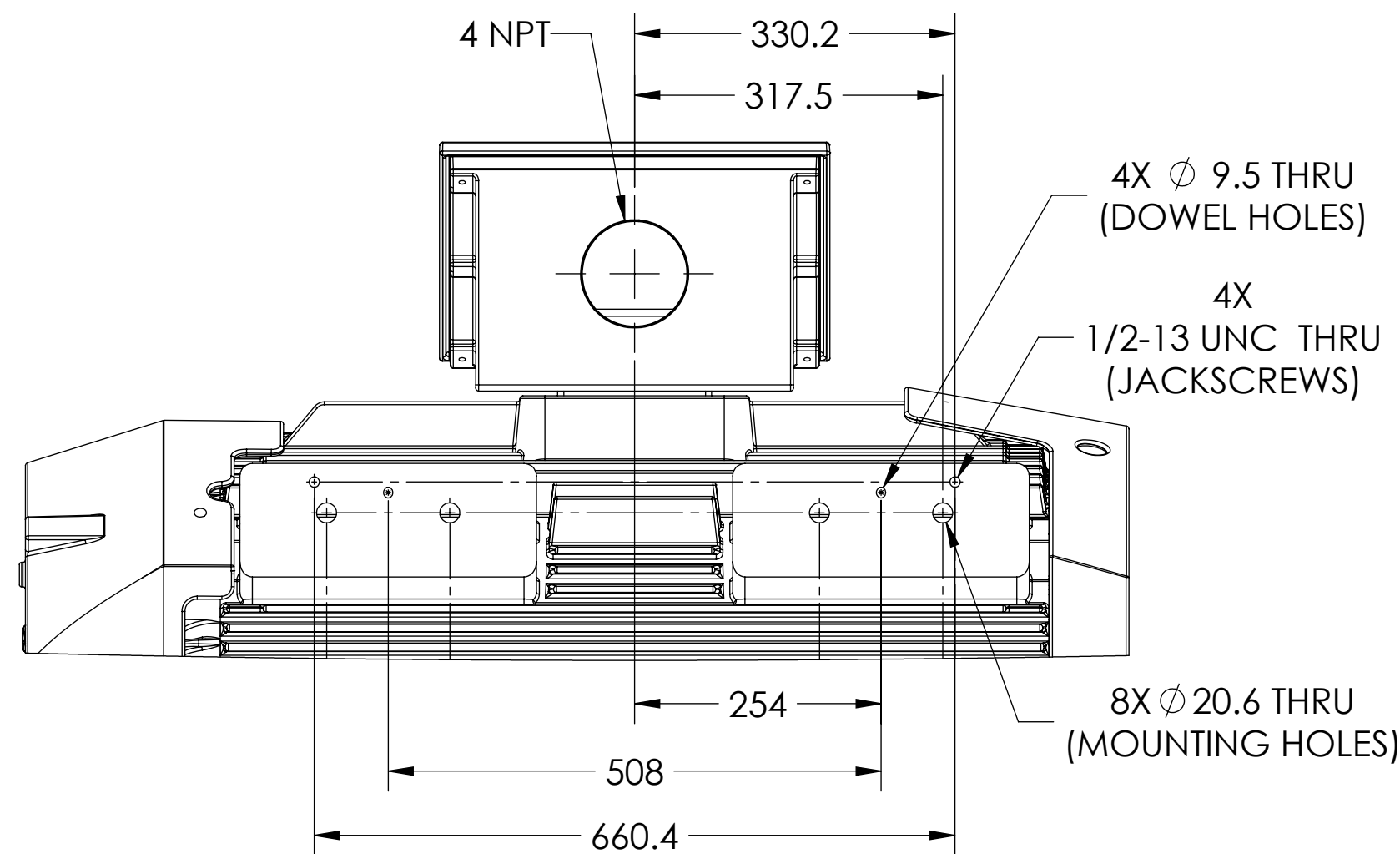
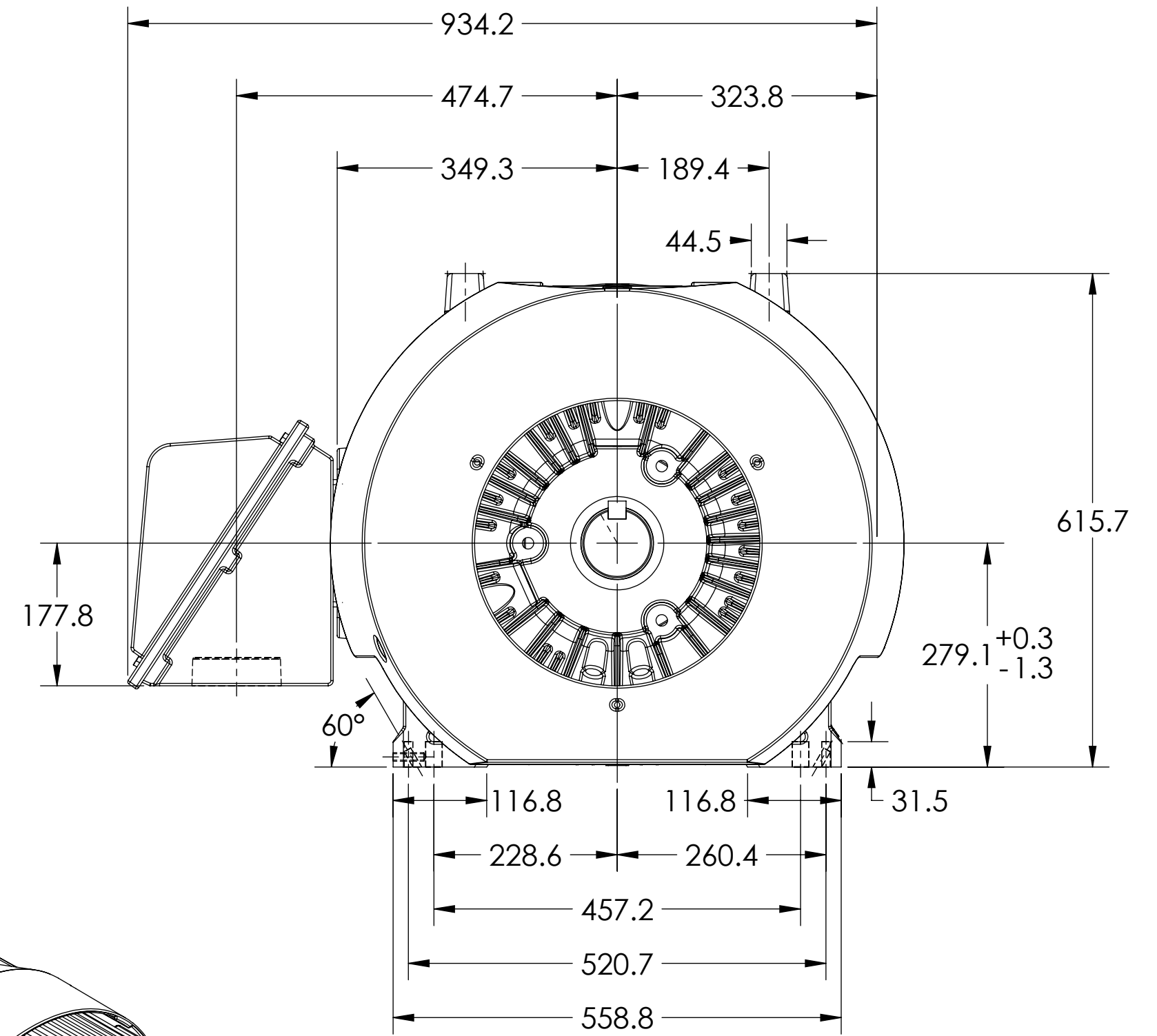
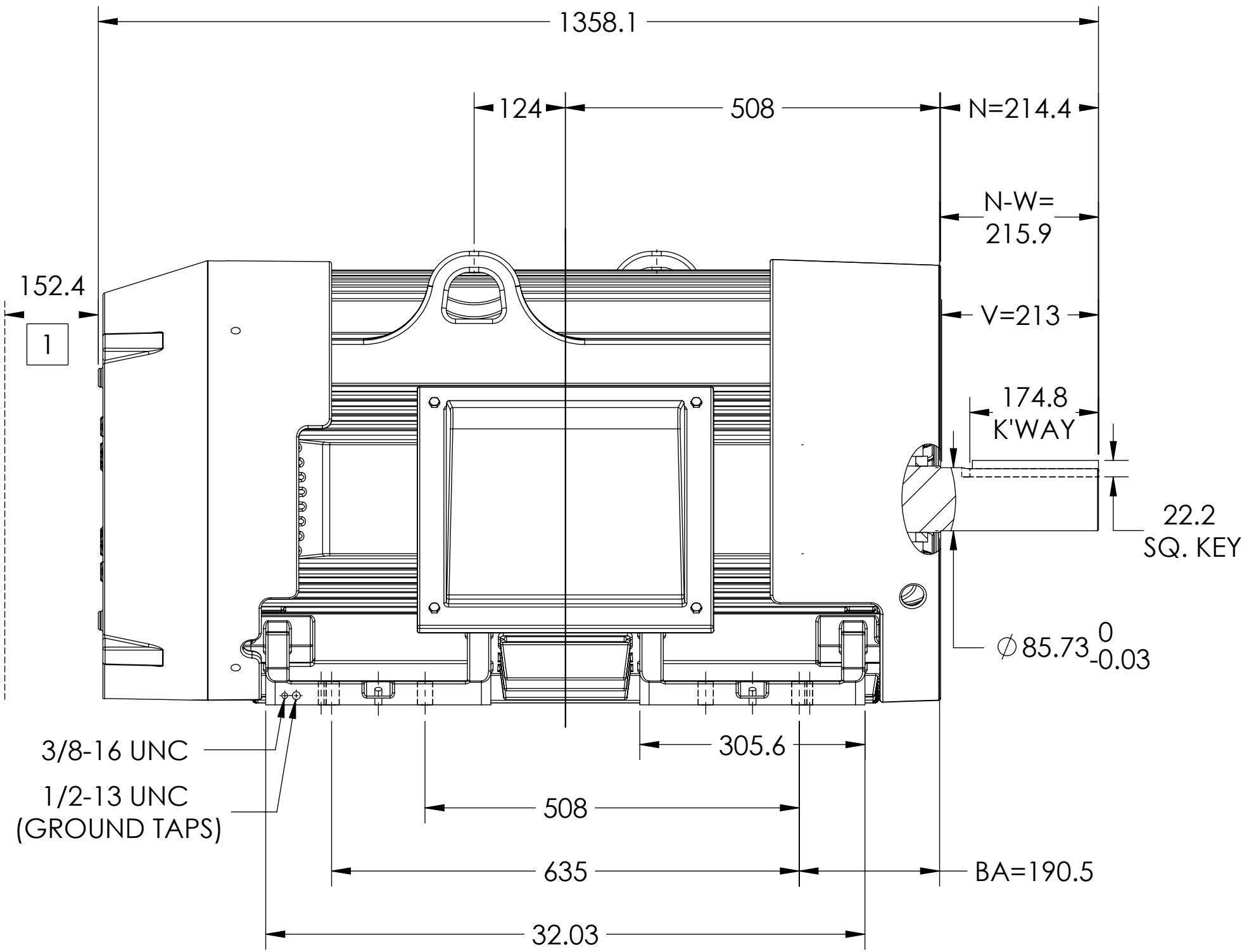

1 OBSTRUCTION MUST NOT ENCROACH ON AIR INLET.

DIMENSIONS ARE IN MILLIMETERS.
WEIGHT (KGS): 1400, MOTOR WEIGHTS MAY VARY BY 15% DEPENDING ON RATING.
CUSTOMER IS RESPONSIBLE FOR DETERMINING THAT MOTOR PERFORMANCE IS SUITABLE IN THE APPLICATION.
MAXIMUM PERMISSIBLE SHAFT RUNOUT WHEN MEASURED AT END OF STANDARD SHAFT EXTENSION IS .04 T.I.R

REV. DESC: NEW DRAWING	VERSION: 00	REVISED: 10:07:48 12/19/2018	TDR: 000001093412
MODEL NO. 617434-665			
BY: USJEDIL			

BALDOR

G449/447T TEFC FOOT F1 C1 BOX/JACKSCREWS/DOWEL PINS/INPROS