

# DUTY MASTER ALTERNATING CURRENT MOTORS

SQUIRREL-CAGE INDUCTION

ENCLOSURE: TOTALLY ENCLOSED

COOLING: FAN COOLED

MOUNTING: FOOT, F-1 SIDE

G444TS/G445TS FRAME MOUNTING HOLES

ENCLOSURE ENHANCEMENT: 841-XL

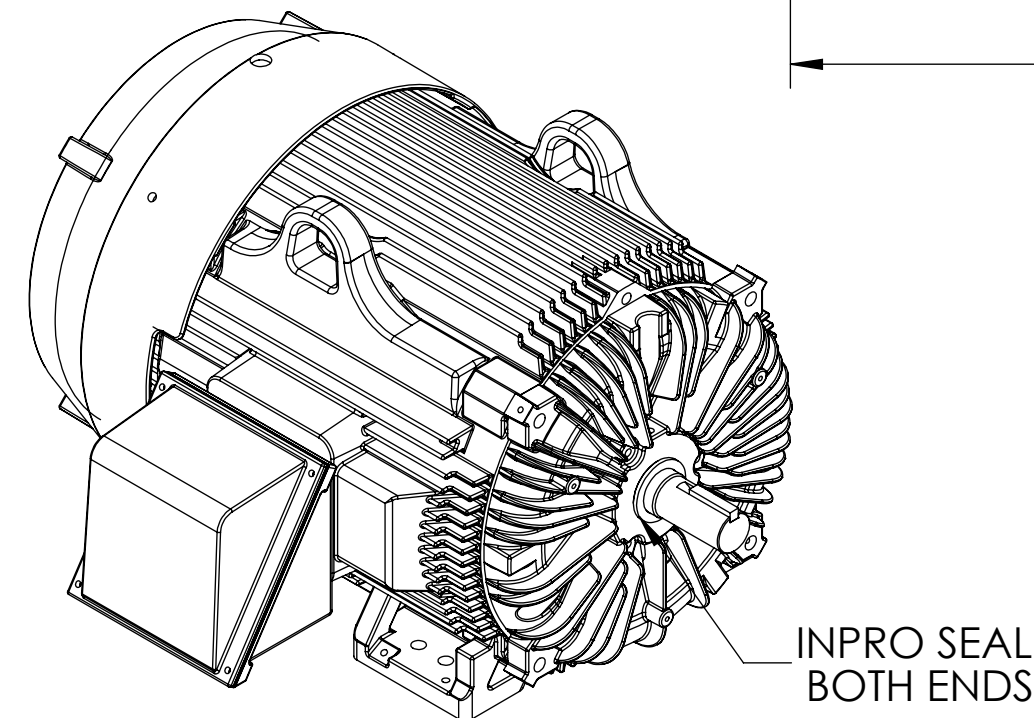
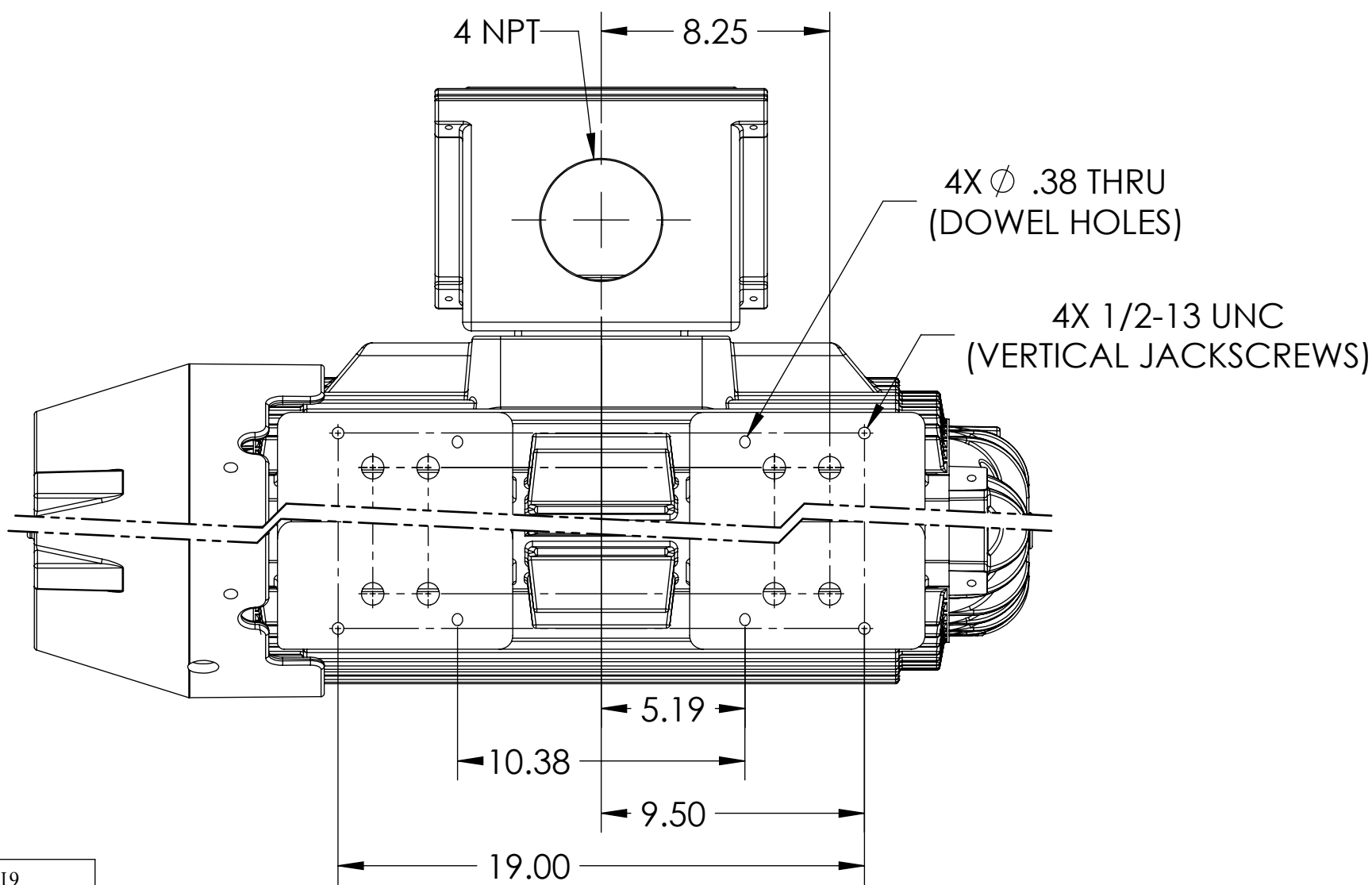
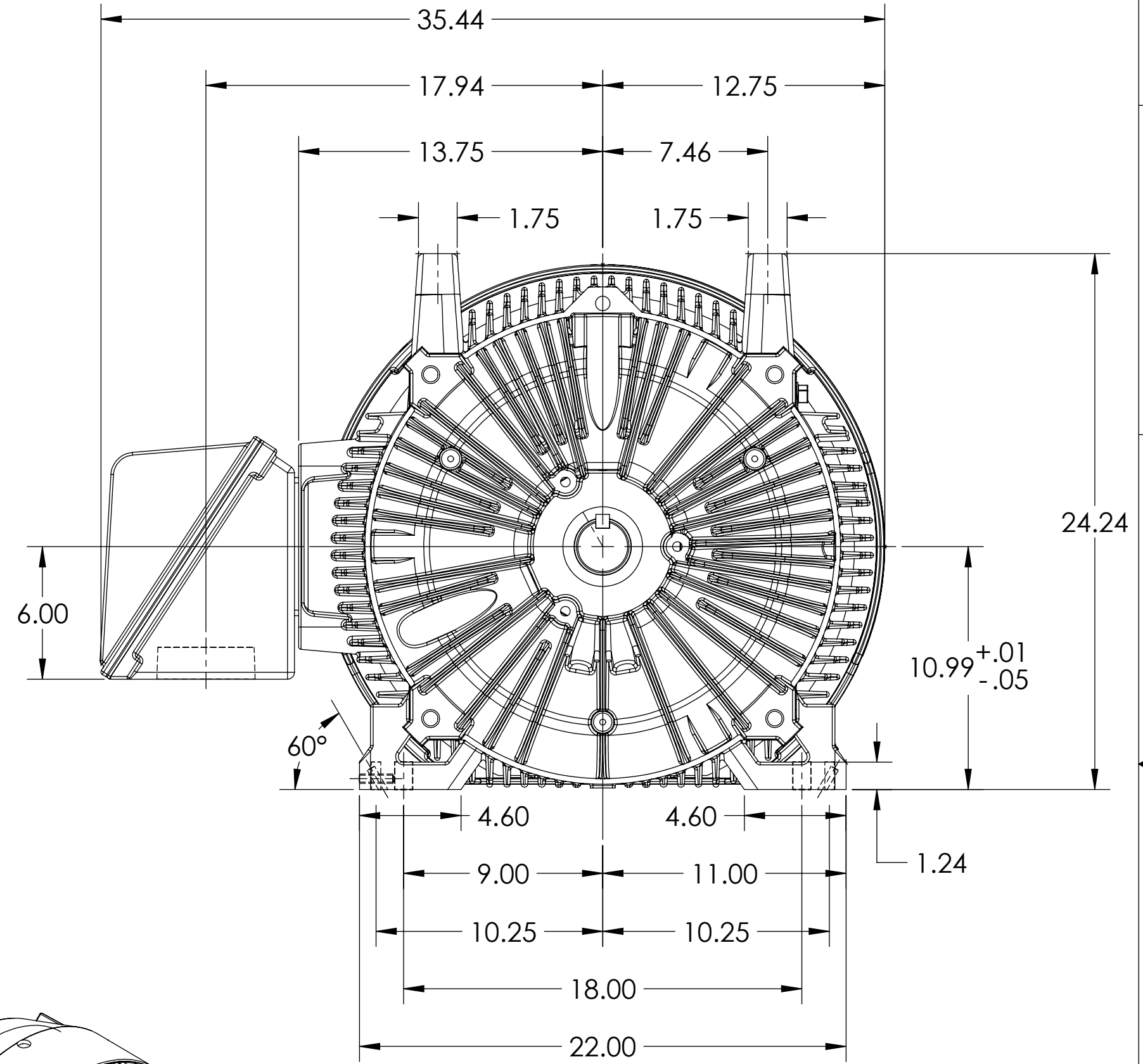
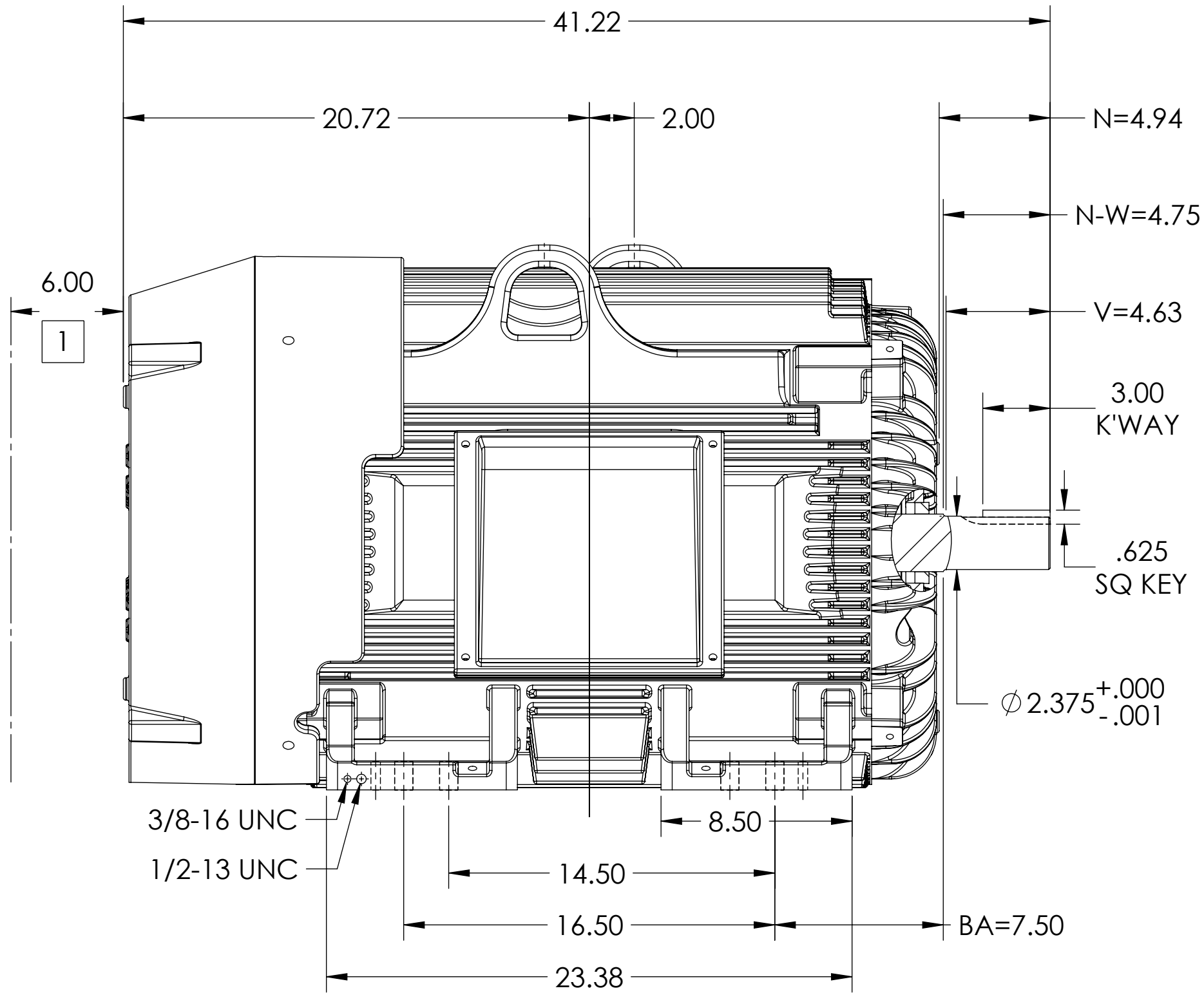

1 OBSTRUCTION MUST NOT ENCROACH ON AIR INLET.

DIMENSIONS ARE IN INCHES.  
WEIGHT (LBS): 2130 ± 15% DEPENDING ON RATING.  
IF MOUNTING CLEARANCE DETAILS ARE REQUIRED, CONSULT FACTORY.  
CUSTOMER IS RESPONSIBLE FOR DETERMINING THAT MOTOR PERFORMANCE IS SUITABLE IN THE APPLICATION.  
MAXIMUM PERMISSIBLE SHAFT RUNOUT WHEN MEASURED AT END OF STANDARD SHAFT EXTENSION IS .0015" T.I.R.

REV. DESC: NEW DRAWING			
REV: -	VERSION: 00	REVISED: 09:24:03 02/15/2019	TDR: 000001099645
MODEL NO. 617434-701		REF: -	
BY: USJEDIL	Material: -		

**BALDOR**

G445/444TS TEFC F1 FOOT CI BOX 4 NPT/JACKSCREW/DOWELS/INPROS

# DUTY MASTER ALTERNATING CURRENT MOTORS

SQUIRREL-CAGE INDUCTION

ENCLOSURE: TOTALLY ENCLOSED

COOLING: FAN COOLED

MOUNTING: FOOT, F-1 SIDE

G444TS/G445TS FRAME MOUNTING HOLES

ENCLOSURE ENHANCEMENT: 841-XL

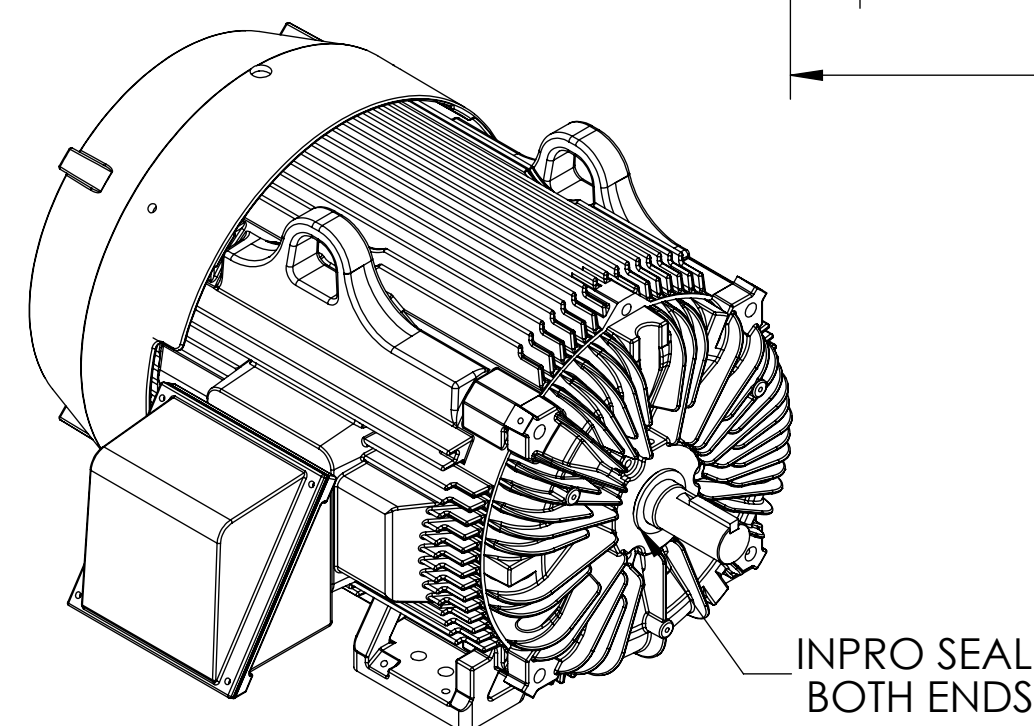
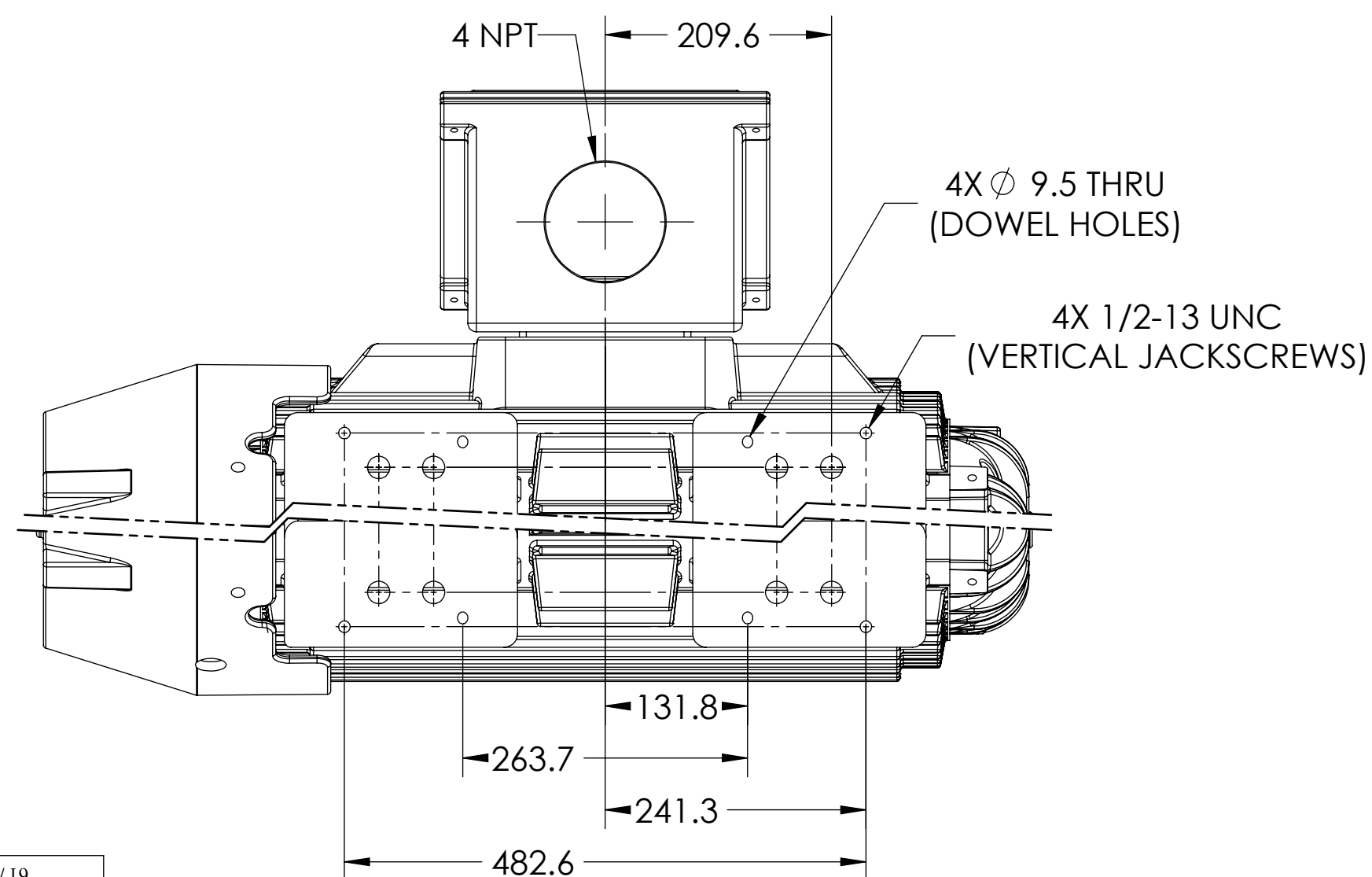
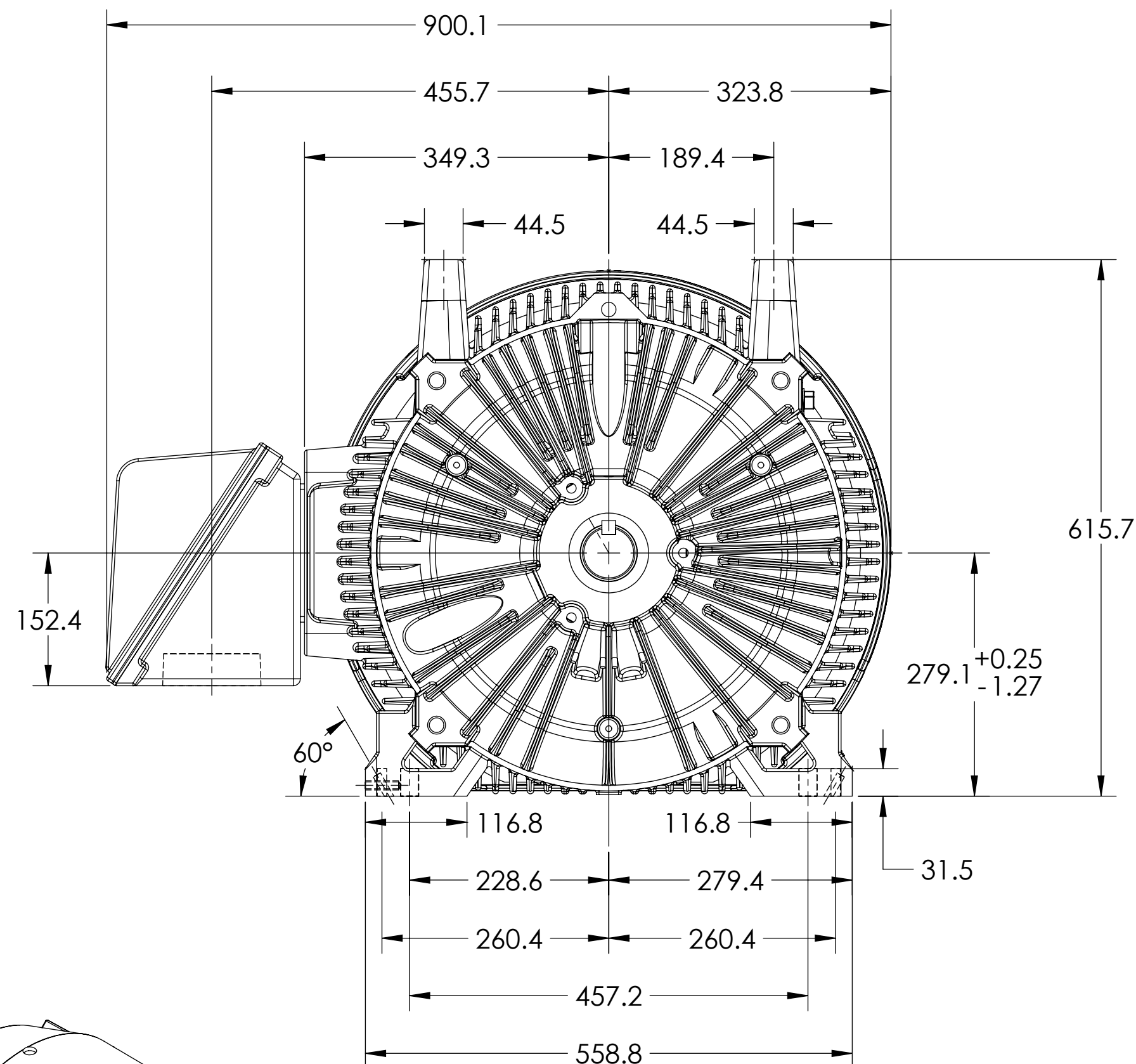
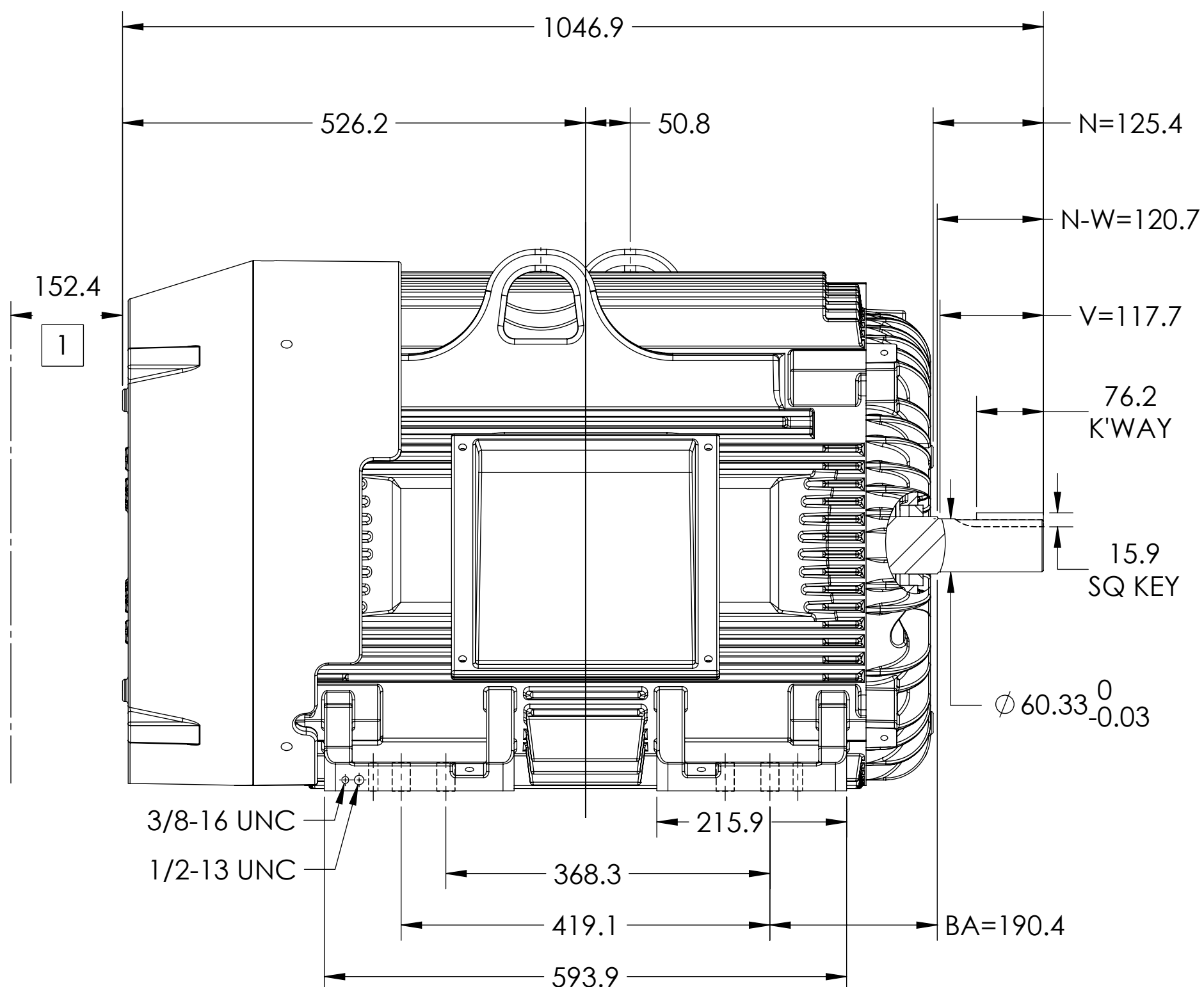

1 OBSTRUCTION MUST NOT ENCROACH ON AIR INLET.

DIMENSIONS ARE IN MILLIMETERS.  
WEIGHT (KGS): 966 ± 15% DEPENDING ON RATING.  
IF MOUNTING CLEARANCE DETAILS ARE REQUIRED, CONSULT FACTORY.  
CUSTOMER IS RESPONSIBLE FOR DETERMINING THAT MOTOR PERFORMANCE IS SUITABLE IN THE APPLICATION.  
MAXIMUM PERMISSIBLE SHAFT RUNOUT WHEN MEASURED AT END OF STANDARD SHAFT EXTENSION IS .04 T.I.R.

REV. DESC: NEW DRAWING			
REV: -	VERSION: 00	REVISED: 09:24:03 02/15/2019	TDR: 000001099645
MODEL NO. 617434-701		REF: -	
BY: USJEDIL	Material: -		

**BALDOR**

G445/444TS TEFC F1 FOOT CI BOX 4 NPT/JACKSCREW/DOWELS/INPROS