

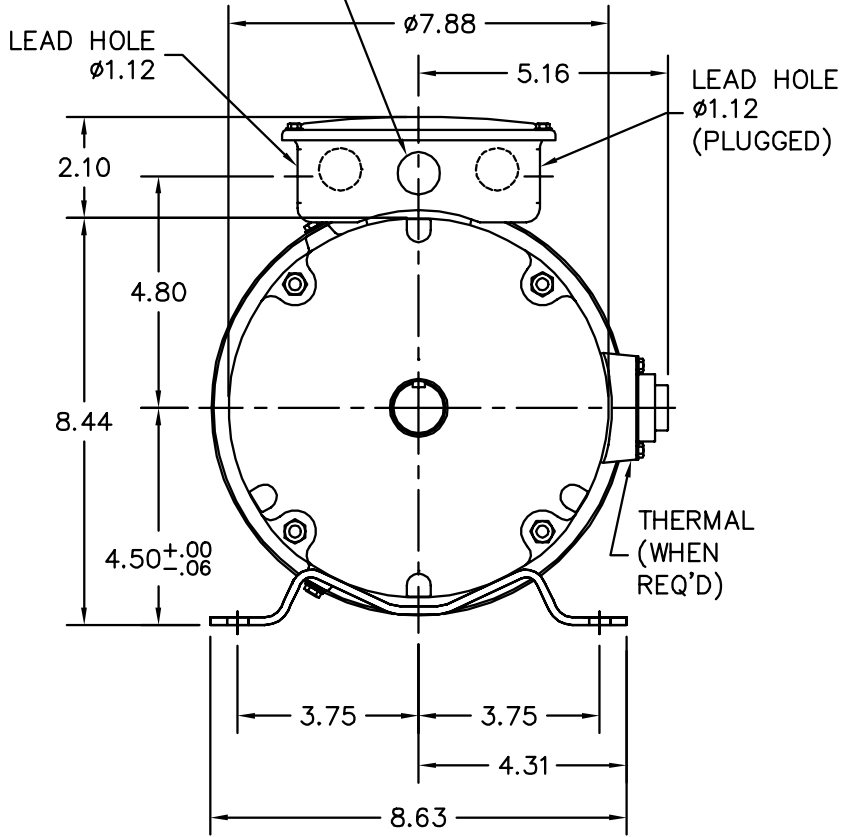

1 X Ø.88 KNOCKOUT (PU END)
 2 X Ø.88 KNOCKOUTS (FR END)



CUSTOMER IS RESPONSIBLE FOR DETERMINING THAT BALDOR'S PRODUCT WILL PERFORM SUITABLY IN THE INTENDED APPLICATION.

REV. DESC: NEW		
REV. LTR: -	VERSION: 00	TDR: 00000947319
FILE: \AAA\00222\746	REVISED: 03:20:04 10/30/2015	BY: ENCARCO
MTL: -		

BALDOR

HORZ 182-4T TEFC 36M F3 W/DODGE SSB BRAKE & 35CB4007

SH 1 of 1